

2023-07

Smart system for monitoring and controlling oxygen gas level in high purity germanium detector room: a case study of Tanzania atomic energy commission, Arusha-Tanzania

Uwamahoro, Yvonne

NM-AIST

<https://doi.org/10.58694/20.500.12479/2217>

Provided with love from The Nelson Mandela African Institution of Science and Technology

**SMART SYSTEM FOR MONITORING AND CONTROLLING OXYGEN
GAS LEVEL IN HIGH PURITY GERMANIUM DETECTOR ROOM:
A CASE STUDY OF TANZANIA ATOMIC ENERGY COMMISSION,
ARUSHA-TANZANIA**

Yvonne Uwamahoro

**A Project Report Submitted in Partial Fulfilment of the Requirements for the Degree of
Master of Science in Embedded and Mobile Systems of the Nelson Mandela African
Institution of Science and Technology**

Arusha, Tanzania

July, 2023

ABSTRACT

Low-oxygen air causes death all around the world. Even though the number of fatalities varies from year to year and location to location, nitrogen gas replaces oxygen in the atmosphere, increasing its percentage to less than 21% by volume. Special environment/room such as High Purity Germanium Detector Room (HPGDR) requires tailored techniques to ensure that oxygen levels are properly monitored to avoid any hazard. This study was designed for the HPGDR at Tanzania Atomic Energy Commission (TAEC). The V-Model was used which works well for small projects with clear requirements. It facilitated each step before moving on to the next level of development, resulting in the design of an error-free and high-quality system. The ESP32 microcontroller which is built in Wi-Fi was used to send data to the Blynk cloud server. The developed system is made up of four parts: The sensing component continuously monitors environmental parameters with Oxygen, MQ-135, and DHT22 sensors. The processing section processes and analyzes sensor data. The notification component alerts workers via a buzzer and Short Message Service (SMS). While the controlling component replaces the contaminated compressed air with fresh air from outside. To provide real-time monitoring, the developed system employs the Blynk Application. All processed data was accessible via mobile phones using the Blynk application. The system eliminates both danger and fear because it alerts workers through SMS and switches on exhaust fan automatically. The HPGDR workers and the administrators are the main beneficiaries of the developed system.

DECLARATION

I, Yvonne Uwamahoro, do hereby declare to the Senate of the Nelson Mandela African Institution

DECLARATION

I, Yvonne Uwamahoro, do hereby declare to the Senate of the Nelson Mandela African Institution of Science and Technology that this project report is my original work and that it has neither been submitted nor being concurrently submitted for a similar degree award in any other institution.



Yvonne Uwamahoro

24/8/2023

Date

The above declaration is confirmed by:

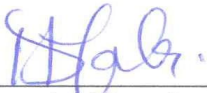

Dr. Devotha Nyambo

29/8/2023

Date



Prof. Anael Sam

25/08/2023

Date

COPYRIGHT

This project report is a copyright document protected under the Berne Convention, the Copyright Act of 1999 and other international and national enactments, in that behalf, on intellectual property. It must not be reproduced by any means, in full or in part, except for short extracts in fair dealing; for researcher private study, critical scholarly review or discourse with an acknowledgment, without the written permission of the office of Deputy Vice Chancellor for Academic, Research and Innovation on behalf of both the author and the Nelson Mandela African Institution of Science and Technology (NM-AIST).

CERTIFICATION

The undersigned certify that they have read and hereby recommend for acceptance by the Nelson Mandela African Institution of Science and Technology a project report entitled: "*Smart System for Monitoring and Controlling Oxygen Gas Level in High Purity Germanium Detector Room: A Case Study of Tanzania Atomic Energy Commission*", in partial fulfilment of the requirements of the Degree of Master of Science in Embedded and Mobile Systems of the Nelson Mandela African Institution of Science and Technology.



Dr. Devotha Nyambo

29/8/2023

Date



Prof. Anael Sam

25/08/2023

Date

NM - AIST
LIBRARY
RESERVE BOOKS

ACKNOWLEDGEMENTS

First and foremost, I give thanks to the Almighty God for his grace and abundant blessings from the time I start my project to its successful final stage. Secondly, I would like to thank my supervisors: Dr. Devotha Nyambo and Prof. Anael Sam and Industrial Supervisor: Eng. John Ngatunga for their supervision, support and mentorship from the start of the project to the end. Thirdly, I would like to thank and express my deepest gratitude to The Nelson Mandela African Institution of Science and Technology (NM-AIST) and School of Computational and Communication Science and Engineering (CoCSE). Fourthly, I would like to thank my sponsor The Centre of Excellence for ICT in East Africa (CENIT@EA). Fifthly, I am thankful to my friends and family members for their encouragement and support in various ways.

DEDICATION

This project report is dedicated to my mother, family members and friends for both emotional and academic supports.

TABLE OF CONTENTS

ABSTRACT	i
DECLARATION	ii
COPYRIGHT	ii
CERTIFICATION.....	iv
ACKNOWLEDGEMENTS	v
DEDICATION	vi
TABLE OF CONTENTS	vii
LIST OF TABLES	ix
LIST OF FIGURES.....	x
LIST OF APPENDICES	xii
LIST OF ABBREVIATIONS AND SYMBOLS.....	xiii
CHAPTER ONE	1
INTRODUCTION.....	1
1.1 Background of the Problem.....	1
1.2 Statement of the Problem	3
1.3 Rationale of the Study	4
1.4 Project Objectives.....	4
1.4.1 Main Objective	4
1.4.2 Specific Objectives	4
1.5 Project Questions.....	5
1.6 Significance of the Study.....	5
1.7 Delineation of the study.....	5
CHAPTER TWO.....	6
LITERATURE REVIEW	6
2.1 Overview	6
2.2 Related Works	7
CHAPTER THREE.....	10

MATERIALS AND METHODS	10
3.1 Overview	10
3.2 Area of the Study	10
3.3 Data Collection	11
3.4 System Development Approach	11
3.5 Why V-Model?	13
3.6 Design Phase	13
3.6.1 Requirement Analysis	13
3.6.2 System Design	13
3.6.3 System Architectural Design	13
3.6.4 Module Design	13
3.6.5 System Requirements	14
CHAPTER FOUR	27
RESULTS AND DISCUSSION	27
4.1 Results	27
4.1.1 Overview	27
4.1.2 Validation and Results of the Developed System	27
4.2 Discussion	36
CHAPTER FIVE	37
CONCLUSION AND RECOMMENDATIONS	37
5.1 Conclusion	37
5.2 Recommendations	38
REFERENCES	39
APPENDICES	42
RESEARCH OUTPUTS	1

LIST OF TABLES

Table 1:	Comparison between V-Model and Waterfall Model	11
Table 2:	Hardware Components used	15
Table 3:	System Testing Results	28
Table 4:	Functional requirements validation results	35
Table 5:	Non-functional requirements validation results	35

LIST OF FIGURES

Figure 1:	Waterfall SDLC	12
Figure 2:	V-Model SDLC.....	12
Figure 3:	ESP32	15
Figure 4:	Liquid Crystal Display Module.....	16
Figure 5:	GSM SIM800L Module	16
Figure 6:	Buzzer	17
Figure 7:	Grove - Gas Sensor (O2).....	17
Figure 8:	Air Quality Sensor (MQ-135)	18
Figure 9:	Exhaust Fan.....	18
Figure 10:	Power Relay Module.....	19
Figure 11:	DHT22	19
Figure 12:	5V /20W SMPS (HLK-20M05)	20
Figure 13:	DS3231 Real Time Clock (Microless, 2011)	20
Figure 14:	Arduino Integrated Development Environment	21
Figure 15:	Blynk application (Media's <i>et al</i> , 2019).....	22
Figure 16:	The Developed System's Block Diagram	24
Figure 17:	Developed System's Flowchart.....	25
Figure 18:	Developed System's Schematic Diagram.....	26
Figure 19:	Testing LCD	28
Figure 20:	Testing LCD with codes.....	29
Figure 21:	Testing the complete system	29
Figure 22:	Complete system testing	30
Figure 23:	Blynk App with the result on safe air quality	31
Figure 24:	Blynk App with the result on unsafe air quality	32
Figure 25:	System at off state before being switched on	33
Figure 26:	System displaying oxygen, air quality and temperature levels in safe mode	33
Figure 27:	System displaying oxygen, air quality and temperature levels in unsafe mode	33

Figure 28: Showing the results through SMS34

Figure 29: Results on oxygen and air quality34

Figure 30: Results on temperature and humidity35

LIST OF APPENDICES

Appendix 1: Program source codes.....	42
---------------------------------------	----

LIST OF ABBREVIATIONS AND SYMBOLS

AC	Alternative Current
ADC	Analog-to-Digital Converter
DHT22	Temperature and Humidity Sensor
EEPROM	Electrically Erasable Programmable Read-Only Memory
ESP	Electronic Stability Control
GSM	Global System for Mobile communication
HPGe	High Purity Germanium
IDE	Integrated Development Environment
ICT	Information and Communication Technology
I2C	Inter-Integrated Circuit
iOS	iPhone Operating System
IoT	Internet of Things
LCD	Liquid Crystal Display
LED	Light Emitting Diode
LPG	Liquefied Petroleum Gas
OSHA	Occupational Safety and Health Administration
PC	Personal Computer
PCB	Printed Circuit Board
RTC	Real Time Clock
SCBA	Self Contained Breathing Apparatus
SMPS	Switched-Mode Power Supply
SMS	Short Message Service
SPI	Serial Peripheral Interface
TAEC	Tanzania Atomic Energy Commission
TCXO	Temperature Compensated Crystal Oscillator
TX/RX	Transmit and Receive
UART	Universal Asynchronous Receiver Transmitter
USP	Universal Serial Peripheral
WHO	World Health Organization
Wi-Fi	Wireless Fidelity

NO₂

Nitrogen Dioxide

CHAPTER ONE

INTRODUCTION

1.1 Background of the Problem

Due to the danger imposed by nitrogen gas on human life when it exceeds its safe level of 78% by volume in air, this project is necessary to avert loss of human lives in Tanzania Atomic Energy Commission (TAEC) and beyond. Around the World, inhaling oxygen-deficient air results in deaths, though the number of fatalities varies from year to year and place to place, Nitrogen gas eliminates oxygen in the air, decreasing the percentage of oxygen in the air to less than 21% by volume, which is hazardous to human life. According to Maloney (2012) since 1992 to 2002, 85 incidents of nitrogen asphyxiation resulted in 80 deaths and 50 injuries and also as Anon (2021) reported from 2012 to 2020 fourteen workers in the US, died from asphyxiation linked to nitrogen accidents. Nitrogen gas can displace oxygen in the air, dropping the percentage of oxygen in the air down below 21% by volume. Due to the massive liquid to gas expansion that occurs during evaporation, liquid nitrogen is capable of displacing enough oxygen to create an oxygen-deficient environment in a small or inadequately ventilated room in TAEC, posing a danger of asphyxiation (Green *et al.*, 2019). This system is not only applicable to TAEC, but the entire world. At the time of development of the project, there is no system that can perform what this system is designed to do. Human brain requires an ongoing flow of oxygen to stay active; without it, the brain cannot operate correctly, which can eventually lead to death. Therefore, this system is designed to provide protection to all humans all over the world.

The only gas that sustains life is oxygen. Approximately 21% oxygen by volume in the air typical considered safe to breathe (Nitrogen, 2014). If the concentration of oxygen falls below 19.5%, the atmosphere becomes dangerous (Yanisko & Croll, 2012). When the oxygen concentration falls only a little below the normal, focus, thinking, and decision-making are all hampered. These side effects are undetectable to the person who is affected. If the oxygen concentration in the air declines or the concentration of any other gases rises, it cause a condition where asphyxiation is a serious risk arises quickly (AIGA, 2008). Oxygen deficiency can have a range of impacts on the human body, keep in mind that different people will respond in different ways when the local oxygen content falls below 19.5% by volume (Resch, 2014). Working in or entering a room with a low oxygen level might result in unconsciousness and death without warning.

High Purity Germanium Detector is an exceptional device used to detect inner and/or outer contamination of various radioactive gamma emitters of a person. This device plays an important role in nuclear safety. It enables the performance of quantitative and qualitative analyses of

radioactivity and specifies the contaminated spots of a human body (head, lungs, or legs) (Dararutana & Abdullah, 2021).

Liquid nitrogen is used as a coolant to create an inert atmosphere in laboratories and elsewhere. 'Cryogenic' or very low-temperature liquid nitrogen is stored at temperatures below -196°C , which is known as cryogenic storage. Skin and other tissues can be damaged by having contact with liquid or vapor at such temperatures (Glasgow, 2010).

Because of its exceptional cryogenic qualities, liquid nitrogen is widely employed throughout the world. Because it is produced by the freezing of air at atmospheric pressure, it has no color, smell, or taste, and a temperature of -196°C . For chilling the HPGD to its working temperature, liquid nitrogen is employed. Users of chilled detectors should be aware of the dangers associated with the cryogenic fluid being used before using the device (Cryogen, 2008).

However, if liquid nitrogen is not handled properly, it can be harmful. Liquid nitrogen, which is colorless, odorless, and tasteless, can inflict frostbite or cryogenic burns, and if used or spilled in a confined place, it can kill a person (Wallace, 2004). This is due to liquid nitrogen's enormous evaporation expansion ratio: One liter of liquid nitrogen can produce 700 liters of gas. As a result, only a minimal amount of liquid nitrogen must evaporate within a room to create an oxygen-deficient environment (Practice *et al.*, 2005). A person cannot breathe if there is not enough oxygen in the room. It is preferable to be alerted than to assume that nothing will happen if liquid nitrogen is accidentally spilled in a confined location (Headlines *et al.*, 2014).

As one of the safety measures for the radioactive mining workers, TAEC has installed a full-body scan device in one of the rooms, which uses liquid nitrogen to keep it cool. Every time liquid nitrogen is refilled, it pours and evaporates in the room. When nitrogen evaporates, it changes to a gas form, which is not possible for a human being to see or smell because it is colorless, odorless, and tasteless (Maloney, 2012). Therefore, no one can know the level of oxygen in the room. It is scientifically proven that exposure to very high level of pure nitrogen can cause dizziness, vomiting, and light headedness and replace oxygen in the room, which eventually can cause loss of consciousness and death (Headlines *et al.*, 2014).

Exposure to nitrogen gas can cause chronic health effects in the long run (Name *et al.*, 1999). Therefore, to create a safe and healthy environment for both the workers and the clients in the full scan room, there is a great need to install a system that can monitor, control and provide information on the level of oxygen in the room before entering, especially if the level of oxygen gas is low, to alert the workers and switch on exhaust fan automatically. Using the Internet, the Blynk application is used to display detected data, process data, and visualize data. Currently, no

system can monitor the level of oxygen gas in the room. For the fear of danger of air impurity, workers open the door and windows because they do not know the level of oxygen in the room. To solve the above-mentioned problem, Smart System for Monitoring and Controlling Oxygen Gas Level in High Purity Germanium Detector Room is proposed. The system stores the data locally in case of connection failure, it can upload all the waiting data lists when the connection is reestablished.

1.2 Statement of the Problem

Based on the fact that TAEC does not have a system to detect the level of oxygen gas in the whole-body scan room and no such existence system to be bought and installed in the room, this formed the basis for the need of this new system because the effects of an oxygen-deprived environment can be severe and cause immediate consequences, such as unconsciousness after only one or two breaths. The exposed individual acquires no notice and is unable to detect a decline in oxygen level (below 19.5% by volume) (Tr & Aksay, 2012). It presents a hazard when nitrogen gas displaces oxygen, making the atmosphere hazardous to humans. Pure nitrogen gas can cause dizziness and light headedness, and it can also replace oxygen in the air, resulting in loss of consciousness and death due to oxygen deficiency (Name *et al.*, 1999). In the absence of a system to detect the level of oxygen gas, industrial workers may be exposed to oxygen deficiency. Providing a smart system for monitoring and controlling oxygen gas level can reduce the number of deaths and injuries caused by lack of it.

Various researches on cryogenic liquid and harmful gases have been previously conducted and different techniques have been developed to monitor, control, and give warnings to the workers. The system developed by Siddharthan (2016) was intended to detect harmful gases using Arduino and GSM Network. It provided the way of notifying workers using buzzer and SMS but failed to remove concentrated air impurity from the room and users could not interact with the system remotely. Gupta *et al.* (2020) developed an IoT based system for Monitoring Air Quality and Gas leak detection for a safer home that was possible to alert workers using buzzer, SMS and the monitored data were displayed locally using LCD display but the system has not provided the solution for removing air impurity from the room using exhaust fan. The study conducted by Moharana *et al.* (2020) was intended to development of an IoT-based Real-Time Air Quality Monitoring Device. It used MQ-135 for monitoring air quality, DHT11 and OLED for locally display. However the system lacks the functionality of removing air impurity even the way of alerting user was only to send a message, here also buzzer can be added. Based on the existing systems there is a need to develop an integrated system with all functionalities such remote alerts with accurate information, local alerts through buzzer and display. Lastly, the system has the ability

to regulate its internal air quality using exhaust fan. These features have made the developed system of more advantages than other systems.

Therefore, the proposed smart system for monitoring and controlling oxygen gas level in high purity germanium detector room will solve the presented gaps from existing systems because it is a user friendly system that helps workers and provides adequate and accurate information for informed decision making.

1.3 Rationale of the Study

The High Purity Germanium Detector Room at TAEC has no system to detect and regulate air impurities installed. Activities in the room are performed under fear of unknown because there is no installed system in the room, no one knows the level of oxygen. Even the system installed by European Union in Food and Environment Monitoring Laboratory at TAEC cannot regulate air impurities and the workers do not have fear as they carry on their daily duties in the room. The existing system can neither automatically expel the excessive air impurity from the room nor send information about the level of oxygen remotely. This system still needs to be upgraded to a level where it will be able to expel excess air impurity from the room without human intervention and provide information about the level of oxygen remotely. The TAEC is facing the aforementioned challenges and need to be addressed satisfactorily. Therefore, TAEC greatly benefits from the developed system because it can monitor any abnormal changes in oxygen level in the room and alert the workers. Also when the system detects any other air impurity in the room, the system can automatically switch on the exhaust fan to remove air impurity to keep oxygen at the correct level in the room. Due to the dangers associated with oxygen deficiency revealed by the literature reviewed, there is a great need to tackle the identified issue in the whole body counter room where liquid nitrogen is used for cooling the system. This is a lifesaving study both for TAEC and beyond. Every activity carried out by human beings must protect life and this is why this study is very important.

1.4 Project Objectives

1.4.1 Main Objective

The primary objective of this project was to develop a Smart System for Monitoring and Controlling Oxygen Gas Level in High Purity Germanium Detector Room at TAEC.

1.4.2 Specific Objectives

- (i) To identify the proposed system's user requirements.

- (ii) To design and develop the proposed system.
- (iii) To implement and validate the proposed system.

1.5 Research Questions

- (i) What are the required functionalities for the proposed system to monitor and control oxygen gas level?
- (ii) What are the required essential steps to design and develop the proposed system?
- (iii) Did the developed system meet the needs of the end users?

1.6 Significance of the Study

The developed system provides a better solution for monitoring and controlling oxygen gas, air quality, and temperature levels to reduce the negative effects of oxygen deficiency in the operation room at the TAEC. It can reduce the fear that causes workers to open door and windows because of liquid nitrogen leakage in the room. It can also help workers to take precaution measures in case the system alerts them of any air impurity in the room. Moreover, the system can both provide alarm and remove the oxygen-deficient air from the room by the use of an automated exhaust fan; also it can help the workers to keep safe from the effect of leaked liquid nitrogen.

1.7 Delineation of the study

The study aimed at monitoring, controlling, and providing information on the levels of oxygen gas, air quality, and temperature in the High Purity Germanium Detector Room at TAEC. I met with the difficulty in locating the essential device, such as a Nitrogen sensor, was one of the project's challenges. The initial plan was to use nitrogen and oxygen sensors together to monitor both the levels of nitrogen and oxygen in the High Purity Germanium Detector Room but Nitrogen sensor was not found in market. As result, only oxygen sensor was used though it took a long time to get it because it was not possible to find it in Tanzania, Rwanda or Kenya. This required ordering an oxygen sensor from China and it took more than two months and a significant amount of money was spent on shipment, as well as delays in the project as a result of the lengthy wait.

CHAPTER TWO

LITERATURE REVIEW

2.1 Overview

The literature review aims at introducing the whole context of the project reviewing the most relevant and up to date available literature. To set a strong foundation for Smart System for Monitoring and Controlling Oxygen Gas level in High Purity Germanium Detector Room, it was of great importance to examine the key literature related to the negative effects of low oxygen, how has it been controlled in similar areas, and what other researchers have failed to include for solving the issue. Through literature review, it was possible to find the gaps in the area and try to mend the gaps using the proposed system.

Because of the lack of a system to monitor the level of oxygen in a room which contains nitrogen, many reviews have shown negative effects of nitrogen gas. Even though nitrogen is safe for humans, it cannot support life and can quickly lead to asphyxia due to oxygen depletion and displacement. As a result, nitrogen is a stifling gas that, like carbon dioxide, causes central nervous system depression (Tr & Aksay, 2012).

Liquid nitrogen-related injuries have been reported where ten people died and other five people got injury. They are mainly caused by direct contact or inhalation of evaporated liquid nitrogen, which affects the tissues of the respiratory system or the intestinal system (Jb *et al.*, 2021).

It has been noticed that in recent years, more attention and research have been turned to indoor air quality than equally considering outdoor air quality, because, on average, the level of air quality which is indoor is greater than the outdoor by two to five times higher and because many people live indoors most of the time. To avoid the negative impact of the primary air pollutants such as nitrogen and others, therefore, a system for monitoring needs to be developed to monitor air quality accurately. Both people's health and the environment can be harmed by pollutants and cause other damages according to the level and location. Several of the devoted researchers have put great efforts into addressing issues related to researches on systems that monitor air quality indoors. It is made known that there is a need to come up with new methodology and modern systems for monitoring air quality in real-time to save human lives (Kim *et al.*, 2014).

Researching and developing systems for monitoring and controlling air quality is very important because this is something that affects human life. Many stories about human deaths due to nitrogen gas inhalation are reported. A 37-year-old male agronomist was found unresponsive in the driver's seat of his car, not in a driving attitude. The man was extracted from the car, but every attempt of

resuscitation was unsuccessful until he was pronounced dead. Five tanks of liquid Nitrogen were placed in the trunk, three of them empty (Lo Faro *et al.*, 2019).

Nitrogen gas has thus no direct toxic effects but when it spreads within small and closed environments, it can displace atmospheric oxygen determining a rapid loss of consciousness when hemoglobin oxygen saturation falls to 70–60% or less. Therefore, monitoring and controlling the level of oxygen in a room with liquid nitrogen is very important because nitrogen affects oxygen level which touch human life negatively (Lo Faro *et al.*, 2019).

2.2 Related Works

Due to the obvious significant negative effects of air pollution on public health, air quality monitoring is becoming highly relevant. The Bangladesh study underscored the importance of monitoring Methane gas, which can cause asphyxiation at excessively high levels and displace oxygen in the blood, resulting in unconsciousness or death. Data collected by sensors were stored in the cloud, the system was able to alert the workers and allowed users to track the surrounding air quality of their home, office, or industries from anywhere. However, the system was not easy to be monitored and controlled remotely even the system lacks the functionality of notifying workers through SMS (Ahmed *et al.*, 2018).

Harmful gases like carbon monoxide, methane, and alcohol are very harmful not only to human beings but also to the environment in general, measures have to be taken by humans to ensure a safe and healthy environment that why MQ-135 is being used to detect other harmful gases in the room. Toxic gas detection systems were developed that employ the Global System for Mobile Communication (GSM) module to generate Short Message Service (SMS) notifications to users and a buzzer to alert them (Siddharthan, 2016). However, this system lacks Internet of Things technology on it because the way of alerting workers was done locally using buzzer and SMS which are not enough. By using Internet of Things technology system can be monitored or controlled remotely.

Furthermore, human beings need to be in an environment that facilitates their living condition because without a good environment where fresh air is available, several problems can put people's lives in danger. One of the important measures to be taken seriously by a human is air quality. Air quality has to be monitored closely because it has a direct influence on human health. It threatens life safety, human productivity and causes discomfort in the ecosystem of urbanization. To effectively control the negative impact of the primary air pollutants such as nitrogen and others gases, there is a need to develop a system for accurately monitoring and regulating air quality. Both people's health and the environment can be harmed by pollutants and cause other damages

according to the level and location. It is made known that there is a need to come up with new methodology and modern systems for monitoring and controlling air quality in real-time to save human lives (Kim *et al.*, 2014).

Gas leakage is a mutual issue in households and manufacturing environments. Its very existence is threatening if it is not detected and controlled right away. Paculanan and Carino (2019) designed system for detection of methane, butane, LPG leak, and methane outflow and alert authorized people via SMS and sound alarm. However, the system lacks the functionality of removing harmful gases from the room.

The effect of domestic and commercial cooking fuel on human health increases daily. According to the research conducted in India by Gupta *et al.* (2020), it shows that every year people lose their lives due to inhaling unsafe air. Therefore, to monitor the concentration of harmful gases in the indoor atmosphere, the system was developed to take up appropriate steps in case gases increase. The system is used for domestic air monitoring purposes in homes or personal indoor spaces to measure the quality of air. However, the way of removing air impurity inside the room was to open doors and windows, the Internet was required to send messages to the user and it was not able to control the system remotely.

Environmental contamination has posed a substantial hindrance to human life in the growing society. Most indoor air quality measures are beyond the threshold of health, therefore it is difficult to maintain a productive and stable environment. The system developed by Jayasree *et al.* (2021) was able to provide real-time monitoring of indoor air quality parameters and alert workers through a subscribed mobile phone. However, the easy way of minimizing the concentration of harmful gases in the room was just to open doors and windows to increase indoor air quality significantly.

The system developed by Ahasan *et al.* (2018) was Arduino based real time air quality monitoring. This system was able to monitor air quality using MQ-135 sensor and display it locally using LCD display. This system needs to be upgraded to a level it can alert workers through buzzer, remotely monitoring and controlling and saving the processed data in the cloud for making decision.

Harmful gas detection and monitoring utilizing internet of things system developed by Kodali and Rajanarayanan (2019). Arduinio Uno R3 board was used as central microcontroller which is connected with sensor. The data received by sensor was stored in internet which could be used for further processing and it could be analyzed for improving safety regulations. Locally the monitored data were displayed using LCD display. However, the system still need to be upgraded to a level what it can notify users using GSM technology and buzzer.

A NodeMCU based Fire Safety and Air Quality Monitoring Device system was developed and intended to monitor the quality of air present in the working environment. Air quality monitoring sensor MQ135, DHT11 (humidity and temperature) sensor were used for monitoring environmental parameters and the Blynk application (an IoT platform) was used for cloud storage. However, the system lacks the notification part either using buzzer or SMS.

Real Time Air Quality monitoring system was developed to help people in avoiding the exposure to the pollutants harmful gases. The raw sensor data collected from the gas sensors was sent to the cloud using an android application. Arduino Nano microcontroller was interfaced with MQ135 sensor and HC-05 module. Locally the monitored raw was displayed using LCD. However, the users need to be alerted using buzzer and SMS.

This chapter reviewed the relevant literature to the project in order to identify a gap in what has been done. Therefore, this chapter helped in identifying a clear gap and developing a solution for covering the identified gap. To address the various challenges presented by the existing systems, the present study shows that there is a need to develop the smart system which can integrate all functionalities reviewed from systems in order to add features.

CHAPTER THREE

MATERIALS AND METHODS

3.1 Overview

The project's development included several procedures, methods, and clear steps to achieve the project's goal. This Chapter describes the methodologies used to conduct this research. It covers the research area, data collection, system development approach, and model used. Data for the project development were gathered from various experts in various fields such as radiation and electronics, and ICT at TAEC.

3.2 Area of the Study

This study was conducted at Tanzania Atomic Energy Commission (TAEC) located in Arusha district, Njiro subward. The TAEC, is the government regulatory organization in charge of all atomic energy affairs in Tanzania. It was formed by the Atomic Energy Act No. 7 of 2003. The TAEC was established with responsibilities; control of the uses of ionizing and non-ionizing radiation sources, as well as the promotion of safe and peaceful usage of atomic energy and nuclear technology. Tanzania Atomic Energy Commission headquarters is located at Njiro, Arusha, Tanzania and it has departments such as Control of Radiation Contamination in Foodstuff and Fertilizers, Radiation Safety Inspections, Radioactive Waste Management, Radiotracer Laboratory, Dosimetry and Calibration, Technical Support and Radiation Protection and Nuclear Instrumentation Maintenance. Therefore, the developed project is under the department of Technical Support and Radiation Protection.

The reason of choosing this project under Technical Support and Radiation Protection department was the presence of two rooms and one of them named as food and environment monitoring laboratory. The food and environment monitoring laboratory room is equipped with the system that is installed which can detect an excessive air impurity and the workers do not have fear as they carry on their daily duties in the room. The existing system in this room can detect an excessive air impurity and alert workers but it can neither automatically expel the excessive air impurity from the room nor send information about the level of oxygen gas remotely. This system still needs to be upgraded to a level where it will be able to expel excess air impurity from the room without human intervention and provide information about the level of oxygen gas remotely. However, the other room named whole body counter room, there is no any installed system. Activities in this room are performed under fear of the unknown. Because there is no installed system in the room, no one knows the level of oxygen gas in the room.

3.3 Data Collection

In order to study, understand and plan for the required resources for designing and developing the Smart System for Monitoring and Controlling Oxygen Gas Level in High Purity Germanium Detector Room as per the first specific objective of this project, data on end user needs and requirements was locally collected through interviews with staff from department of Technical Support and Radiation Protection Support at TAEC, and observation of High Purity Germanium Detector Room in the organization. The aforementioned data collection methods were used to gain a deeper understanding of concepts and opinions over the proposed system. Furthermore, secondary data were sought through related literature reviews to gain a better understanding of how smart sensors work. The High Purity Germanium Detector Room has been chosen for this project due to that;

3.4 System Development Approach

From the design phase to implementation, a variety of software development techniques can be used in the system development process. The most commonly known and likely to be used are Agile, Waterfall and V-Model. But after analyzing and understanding the requirements to be used for developing the proposed system, I found that both Agile and Waterfall could not be used for the system development because the requirement were well known. The table below shows the comparison between V-Model and Waterfall model

Table 1: Comparison between V-Model and Waterfall Model

S/N	V-Model	Waterfall Model
1	It is possible to test a software during its development.	It is not possible to test a software during its development.
2	Identification of defects can be done from the beginning.	Identification of defects is done in the testing phase.
3		Guarantee of success through Waterfall Model is low.
4	Guarantee of success through V- Model is high. More customer involvement as compared to Waterfall Model	Less customer involvement

We used V-Model in this project because it works well for small projects with clear requirements. It was simple to check each step before moving on to the next level of development, resulting in the development of an error-free and high-quality system. The V-Model is a Software Development

Life Cycle where execution of processes happens sequentially in a V shape (Stephen & Oriaku, 2014).

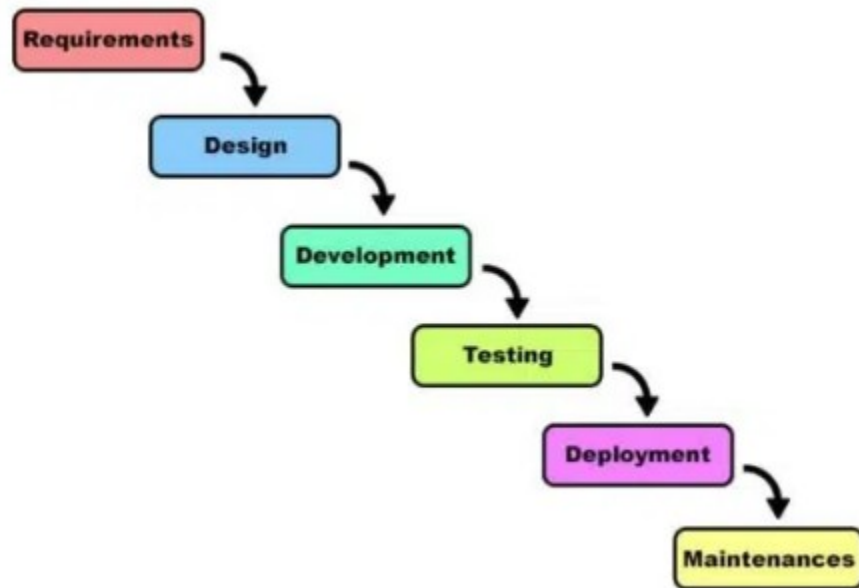

Figure 1: Waterfall SDLC

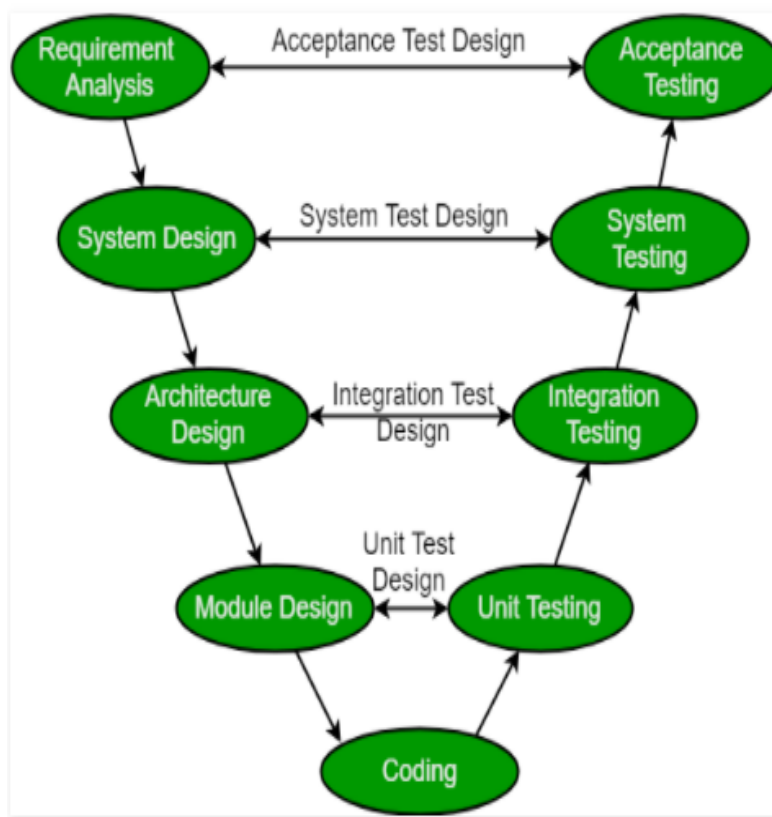

Figure 2: V-Model SDLC

3.5 Why V-Model?

The project was developed using the V-model technique. The V-Model was chosen because all of the system's requirements were known and in place, so, it was easy follow the flow of development. It is the right model for carrying out a project with straightforward specified unchanging requirements (Yadav, 2012). This model is very easy to comprehend and apply (Mathur & Malik, 2010). The simplicity of this model also allows to implement. The V-Model is based on the relationship between each development level hence, facilitated testing at each level against the intended functionality before moving to the next level. This means that there is a testing phase that corresponds to each stage of the development cycle. The following step begins only after the preceding phase is completed (Systems, 2017).

V-Model is simple, easy to understand and use (Yadav, 2012). It focuses on verification and validation activities early in the life cycle thereby enhancing the chance of developing an error-free and good quality product.

3.6 Design Phase

3.6.1 Requirement Analysis

This phase involves extensive communication with the customer to fully comprehend their needs and expectations. This is referred to as the Requirement Gathering step.

3.6.2 System Design

This phase is where the system is designed with complete hardware and software architecture, as well as a setup communication requirement for the system development.

3.6.3 System Architectural Design

In System architectural design, the whole design for achieving various functions is subdivided further into modules. Therefore, for the purpose of understanding the data transfer well, communication between the internal modules with the other outside systems is vividly articulated.

3.6.4 Module Design

The module design is also known as low-level design which is further divided into smaller modules during this phase.

3.6.5 System Requirements

Through unstructured interviews and keenly participatory observations of how High Purity Germanium Detector Room function with respect to fight with exposures of nitrogen gas visa visa deficiency of oxygen gas in the respective room, it was possible to collect satisfactory required information for developing the system. Functional and non-functional requirements are included in the system requirement. Both hardware and software are integral parts of the system requirement.

The requirement of a system is the phase where a system developer must focus on for completing the project. It is at this stage where a system developer carries out a feasibility study to make sure that the system is either doable or not. From the interviews with the staff a feasibility study gives the direction on how the research will be carried out in a successful way (Weik, 2000). When talking about functional requirements, these are what the system is required to do. Functional requirements are the intended outputs from a system. While non-functional requirements are the auxiliary functions that a system can still perform without noticeable negative impact (Documents, 2003).

(i) Functional System Requirements

- (a) The system should have the ability to be powered on through DC and AC sources
- (b) The system should have the ability to detect the level of Oxygen in the room
- (c) The system should have the ability to detect the air quality in the room
- (d) The system should have the ability to detect the temperature in the room
- (e) The system should have the ability to alert workers through the buzzer
- (f) The system should have the ability to send a Short Message Service
- (g) The system should have the ability to provide an interface for accessing the data to the cloud
- (h) The system should be able to be accessible at all times.

(ii) Non-Functional System Requirements

- (a) The system should have the ability to update data on an SD card
- (b) The system ought to be user friendly

(c) The system ought to be essentially acceptable and usable

(d) The system should be secured from external interference

Hardware (Components) Requirements

Hardware components used to develop the proposed system are shown in Table 1.

Table 2: Hardware Components used

S/N	Components	Quantity
1	ESP32-WROOM-32	1
2	20×4 Liquid Crystal Display	1
3	GSM Module	1
4	Buzzer	1
5	Grove-Gas Sensor (O ₂)	1
6	Air Quality Sensor (MQ-135)	1
7	Printed Circuit Board (PCB)	1
8	Exhaust Fan	1
9	Relay Power Module	1
10	Jumper wires	1 Packet
11	DHT22 Temperature and Humidity Sensor	1
12	HLK-20M05	1
13	DS3231 RTC	1

- **ESP32**

The ESP32 is a very versatile system on a Chip (SoC) that can be used as a general-purpose microcontroller with quite an extensive set of peripherals including Wi-Fi and Bluetooth technologies (Espressif Systems [ES], 2021). It operates at 3.0 V-3.6 V of voltage and the CPU clock frequency is adjustable from 80 MHz to 240 MHz (ES, 2021). The module is capable of supporting up to 150 Mbps of data rate with a dBm output power of 20.5 to ensure the widest physical range at the antenna (Agree, 2013). It has a robust design and ultra-low-power consumption. It supports the protocols such as I2C, ADC, SPI, and UART. The aforementioned features cut down the complexity, cost, and hardware bulk to a great extent enabling the user to set up a real-time oxygen gas monitoring and controlling system (ES, 2021). In the developed system ESP32 is used as the brain of the system to control the entire process.

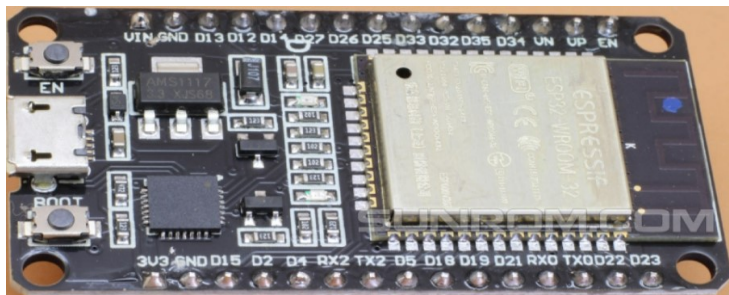

Figure 3: ESP32

- **Liquid Crystal Display Module**

A 20×4 LCD is a type of electronic display device. Liquid Crystal Display is the full form of the term LCD. Because it contains 20 columns and 4 rows, it is referred to as a 20×4 LCD. The 20×4 LCD module is interfaced to the pins of the microcontroller to display the values processed by the Microcontroller (Electronic Project Focus, 2021). In the developed system 20×4 LCD is used to display the levels of oxygen, air quality, and temperature in the room.

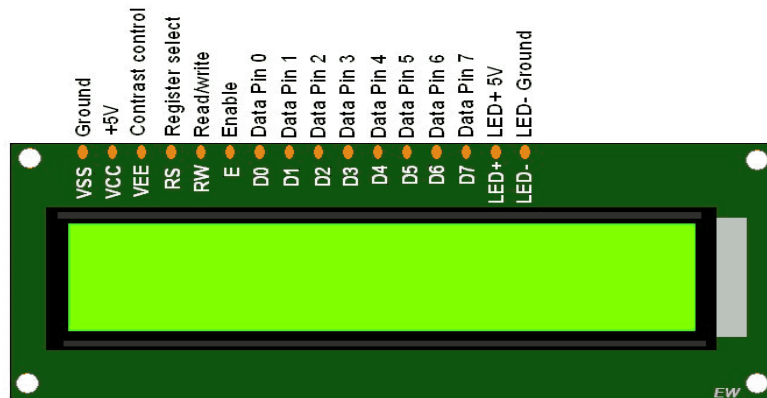

Figure 4: Liquid Crystal Display Module

- **GSM SIM800L Module**

The Global System for Mobile Communication (GSM) is a digital mobile phone telephony system that is widely used in the United Kingdom and throughout the world (Kandel, 2019). The GSM, the most commonly used technology, involves time division multiple access (TDMA) (Kandel, 2019). GSM Modem is used to alert the workers through SMS about the status of air quality, oxygen gas, and temperature in the room via their subscribed phone numbers.



Figure 5: GSM SIM800L Module

- **Buzzer**

A buzzer, often called a beeper, is a variety of audible signaling devices that can be mechanical, electromechanical, or piezoelectric (Tokyo Denki Kagaku Kōgyō [TDK], 2011). It converts

electrical energy into sound energy by using a transistor and a capacitor (TDK, 2011). Alarm devices, timers, and confirmation of user input are the most common uses for buzzers (e.g. mouse click or keystroke) (TDK, 2011). The device performs in a range of voltage of 4 V to 8 V and a resonance frequency of 2300 Hz (TDK, 2011). The main purpose for using a buzzer in this project is to alert the workers in case there is a higher air impurity level, the level of oxygen is below 19.5% by volume and temperature exceeds 20°C in the room.



Figure 6: Buzzer

- **Grove-Gas Sensor (O²)**

Grove-Gas Sensor (O₂) is a variety of sensors used to sense the level of Oxygen in the room (Seed-Studio-Inc [ST], 2015). It is supplied with a voltage from 3.3 V to 5.5 V. The module communicates by indicating the voltage proportional to the concentration of oxygen in the air (ST, 2015). The main features of Grove - Gas Sensor (O₂) is high precision, high sensitivity, wide linearity range, strong anti-interference ability, and extraordinary reliability (ST, 2015). It is applied in oxygen analyzers, air purifiers, and environmental monitoring (Sensor *et al.*, 2022). The developed system uses this sensor to keep track of the amount of oxygen present in the room.



Figure 7: Grove - Gas Sensor (O₂)

- **Sensor for Air Quality (MQ-135)**

The Air Quality Sensor (MQ-135) is highly sensitive to gases such as ammonia, sulfide, benzene, steam, smoke, nitrogen oxide, and carbon dioxide (ST, 2015). It has the potential to detect different

harmful gases (ST, 2015). It operates at a voltage of 5 V and 40 mA current. The conductivity of this gas sensor increases as the concentration of the polluting gas increases. It has a wide detecting scope, good sensitivity is easily interfaced with other devices (ST, 2015). This sensor has high durability and is very accurate (ST, 2015). The purpose of using this sensor in the developed system is to monitor other gases that can cause air impurity in the room.



Figure 8: Air Quality Sensor (MQ-135)

- **Exhaust Fan**

An exhaust Fan is an electronic device used to create a flow of air. In the developed system it is used to remove air impurity from the room and let in the fresh air.



Figure 9: Exhaust Fan

- **Relay Power Module**

A relay is an electronically controlled switch that can be turned on or off, allowing or preventing current flow, and can be controlled using low voltages such as the 5V provided by the microcontroller pins (Schneider Electric [SE], 2010). The purpose of using a relay in the developed system is to switch on and off the exhaust fan automatically in case there is higher air impurity or oxygen level goes below 19.5% in the room.



Figure 10: Power Relay Module

- **Temperature and Humidity Sensor DHT22**

The DHT22 Temperature and Humidity Sensor is used to detect changes in the room's ambient temperature (Adafruit Learning System [ALS], 2010). The sensor has a chip inside that performs the analog to digital conversion and spits out a digital signal with the temperature. The main purpose of using this sensor in the developed system is to accurately monitor the temperature in the room and feed the microcontroller to alert workers through buzzer by beeping and GSM by sending short message service to subscribed phone numbers in case temperature in the room exceeds the threshold. The DHT22 provides a precise value of temperature and long-term stability values are ensured (Edt, 2020).



Figure 11: DHT22

- **5V /20W SMPS (HLK-20M05)**

This is a module that is general with a small volume, enclosed with plastic for being mounted on a PCB. It has an isolated step down high efficiency switching power, which is designed by Hi-Link Company (Rhydo Technologies [RT], 2019). It is used in automation control of smart homes and other industries. It supplies approximately 100V to 240V AC with a power rating of 20 Watt (RT, 2019). It is a desirable component supplying a 5 volt from mains for small projects. This module has many advantages, such as low power, low-temperature rise, high-security isolation, high

efficiency, high reliability and has switching source to deal with fluctuations in the voltage grid (RT, 2019). The purpose of using HLK-20M05 in the developed system is to control the power flow and the model is with the in-built cooling system which prevents overheating. Therefore, it does not require heat sink.



Figure 12: 5V /20W SMPS (HLK-20M05)

- **DS3231 RTC**

DS3231 RTC is a real-time clock module having 32Kbit EEPROM with a built-in sensor of 10-bit temperature with a resolution of 0.25C (Microless, 2011). It is a real-time clock module that has accurate I²C real-time clock (RTC), a low-cost, with an integrated temperature-compensated crystal oscillator (TCXO) and crystal (Microless, 2011). The device incorporates a battery input and maintains accurate timekeeping when the main power to the device is interrupted. The purpose of using RTC in the developed system is to prevent the loss of data.

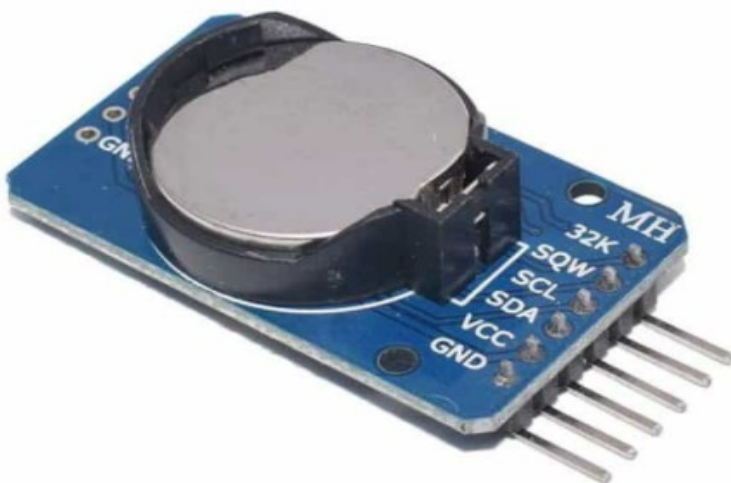

Figure 13: DS3231 Real Time Clock (Microless, 2011)

Software Requirements

- **Arduino Integrated Development Environment**

Arduino Integrated Development Environment (IDE) is one of the open-source software tools consisting of a text editor based on both C++ and C programming languages for writing the program codes (Fezari & Dahoud, 2018). In this project, Arduino IDE software is used to program the Esp32-Wroom-32 Microcontroller. Because it employs C or C ++ programming languages, Arduino IDE has the advantage of being simple to use. Furthermore, Arduino IDE offers a simple integrated platform that can be used on a personal computer (PC). Arduino IDE provides easy means for downloading sensors and other components' libraries (Fezari & Dahoud, 2018).



Figure 14: Arduino Integrated Development Environment

- **Proteus Software**

Labcenter Electronics developed Proteus, a circuit design program. It is used to design various circuits on PCB (printed circuit board) and to simulate various circuits (Enas, 2014). The employment of Proteus for any electronic circuit project keeps costs down and reduces errors due to schematic construction on the Proteus (Enas, 2014). It is the most effective simulation software for a wide variety of microcontrollers (Enas, 2014). Because practically all microcontrollers are available in it, it is essentially common software (Enas, 2014). The Proteus software was used to draw the logical circuits of the system to show how the circuit board looks and how the electronic components are connected.

- **Blynk Application**

Blynk is an iOS and Android application that allows users to simply interact with the system for controlling and monitoring hardware projects (Media's *et al*, 2019). The Blynk was developed with the Internet of Things. It has the ability to control devices remotely and display data collected, it is capable of storing data and visualizing data using the Internet (Media's *et al*, 2019). The user can create a project dashboard and configure buttons and sliders on the screen after downloading and installing the Blynk software. Using the widgets, it can turn pins on and off or display data

from sensors (Sharma & Parveen, 2020). Blynk platform majorly is built on three components (Media's *et al.*, 2019):

(a) Blynk App

The Blynk App enables users to design interfaces for their projects by employing the many widgets available.

(b) Blynk Server

Blynk Server is in charge of all communication between the smartphone and the hardware. Users have the opportunity of using Blynk Cloud or run a private Blynk server locally. It is open-source, can support thousands of devices, and can even run on a Raspberry Pi.

(c) Blynk Libraries

Blynk Libraries are accessible for all common hardware platforms. Libraries allow people to communicate with the server and handle all of the commands that come in and go out.

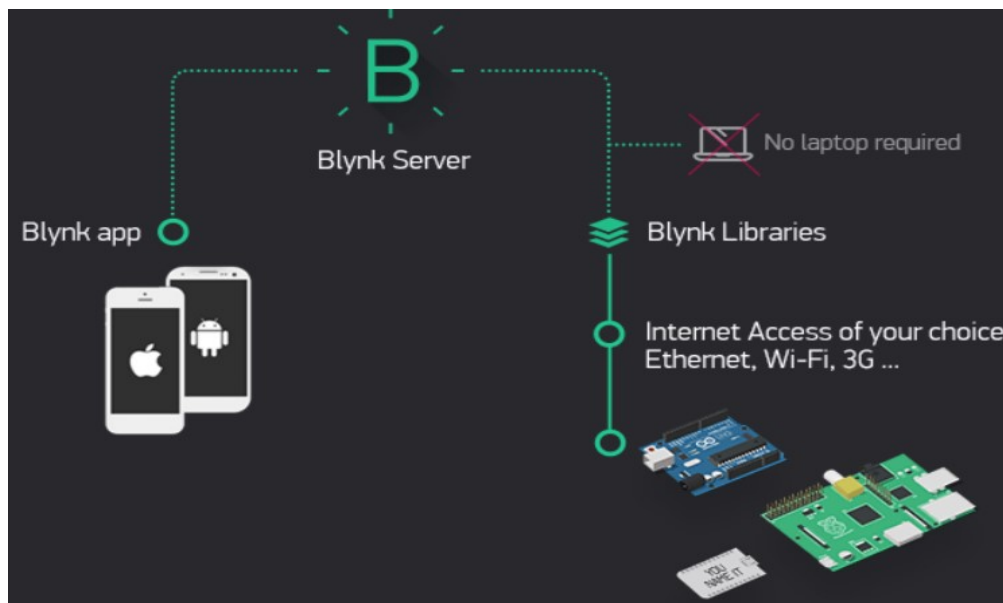

Figure 15: Blynk application (Media's *et al.*, 2019)

- **Draw.io**

Draw.io is a free online application for creating and sharing diagrams and flowcharts. It provides options for storing the saved drawings or flowcharts on a server in the cloud or network-attached storage (NAS) at a data center depending on the needs of the user. Draw.io was especially used in the developed system to illustrate the functionality of the system via a flowchart.

System Design

During the development of the system, the system was designed with four distinct parts known as the sensing part, data processing part, notification or alerting part, and controlling part.

- **Sensing Part**

This part comprises of Grove-gas Sensor (O₂) senses Oxygen gas, MQ-135 senses the presence of other gases that can cause air impurity, and DHT22 Sensor senses the temperature in the room. Grove-Gas Sensor (O₂) is a variety of sensors used to sense the level of oxygen in the room. It is very suitable for detecting oxygen concentration in the environment protection and it has high precision, high sensitivity, wide linearity range, and strong anti-interference ability. It has working voltage ranges of 3.3V-5V and working at temperature ranges -20°C to 50°C. The purpose of using Grove- gas Sensor is to ensure that the oxygen level in the room is monitored to prevent injuries and deaths caused by insufficient oxygen.

The MQ-135 is used to sense the presence of other gases that can cause air impurity in the room and it operates at a voltage of 5.0V. This sensor has high durability and is very accurate. An increase in temperature in the room makes liquid Nitrogen evaporate that is why DHT22 is used to monitor the temperature in the room and report to the microcontroller for a procession. The DHT22 sensor is equipped with an in-built transducer that is capable of converting analog signal to digital signal and outputting an equivalent digital signal with temperature and humidity. It works between voltage ranges of 3V and 5 V. The temperature sensor DHT22 operates between temperature ranges of -40⁰ C and +80°C, with the accuracy of ± 0.5°C, humidity ranges between 0 and 100 %, and an accuracy level between ± 2 and 5 %.

- **Data Processing Part**

In this part, the ESP32 Microcontroller is used as the brain of the system to control the entire system. It operates at 3.0 V-3.6 V of voltage and the CPU clock frequency is adjustable from 80MHz to 240 MHz. Once the data from the sensors are received by the microcontroller, it processes and analyzes the data. After data analysis, the microcontroller compares the sensed values to the threshold values of each data that is programmed in the microcontroller. The use of the ESP32 Microcontroller with Arduino IDE provides a suitable platform for implementing the project which is an embedded control system where hardware is controlled by software.

- **Notification and Controlling Part**

This part consists of a Buzzer, LCD, Relay, and GSM module, when the sensed values exceed the threshold value, the microcontroller sends the signal to Buzzer to alert the workers so that they can get out of the room. This part also helps workers to access information about air impurity, temperature, and oxygen levels in the room both locally and remotely. Locally, it provides information on the levels of air quality, oxygen, and temperature on LCD and Buzzer. The microcontroller sends information to the GSM to alert workers through the subscribed phone numbers in form of SMS. The Blynk App is also used. Through Wi-Fi integrated with the microcontroller, data are stored on the Blynk App server. These data are about air quality, oxygen, and temperature levels in the room. From the Blynk App server workers can access the information remotely before entering the room.

The relay switches on the exhaust fan automatically once air impurity is detected or oxygen goes below the threshold to remove air impurity from the room. The exhaust fan expels the concentrated air impurity and replace it with fresh air from outside.

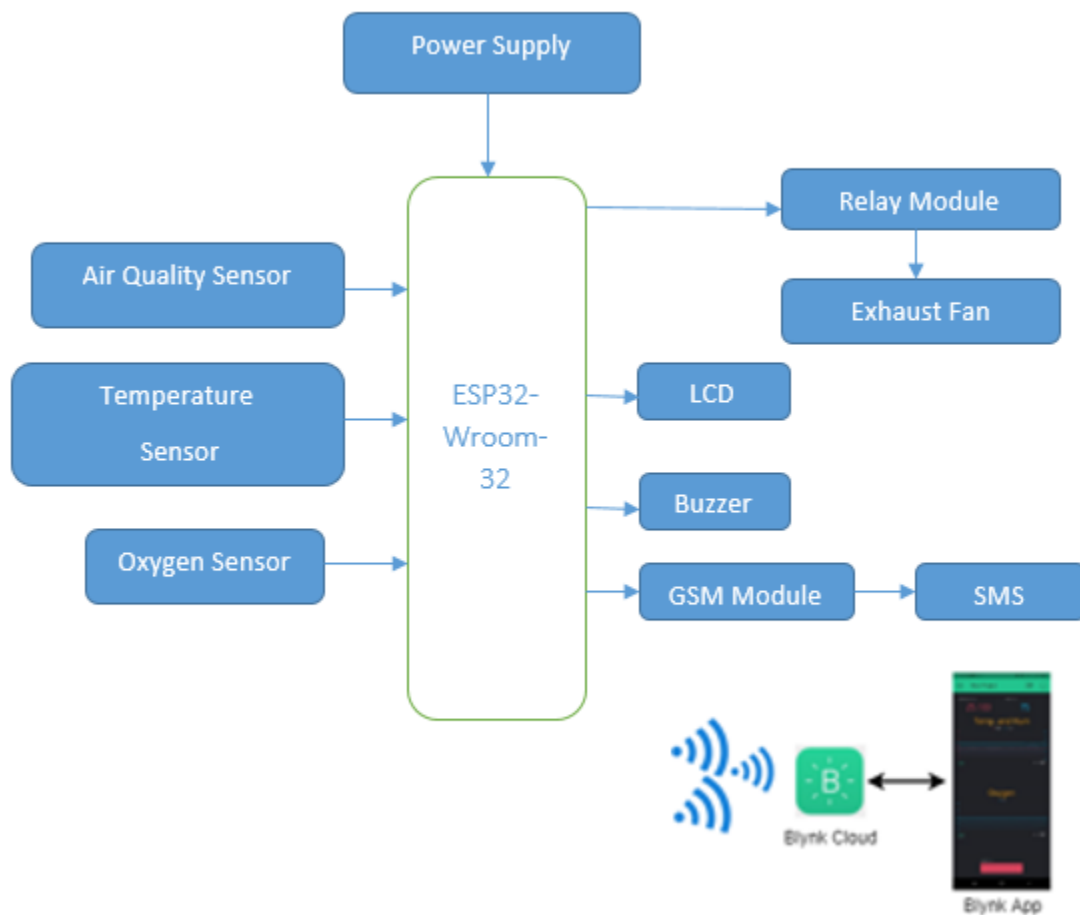

Figure 16: The Developed System’s Block Diagram

The Designed System's Functionality

When the system is switched on, the oxygen sensor starts to sense the concentration of oxygen gas, MQ-135 sensor starts to sense the air quality concentration, and the DHT22 sensor continuously monitors temperature in the room. Immediate actions such as beeping of a buzzer, automatic switching on of exhaust fan are carried out when there is air impurity in the room or oxygen level is low. As result, this triggers the system to send short message service to the subscribed mobile phone. The complete flowchart of how the system works is shown in Fig.17.

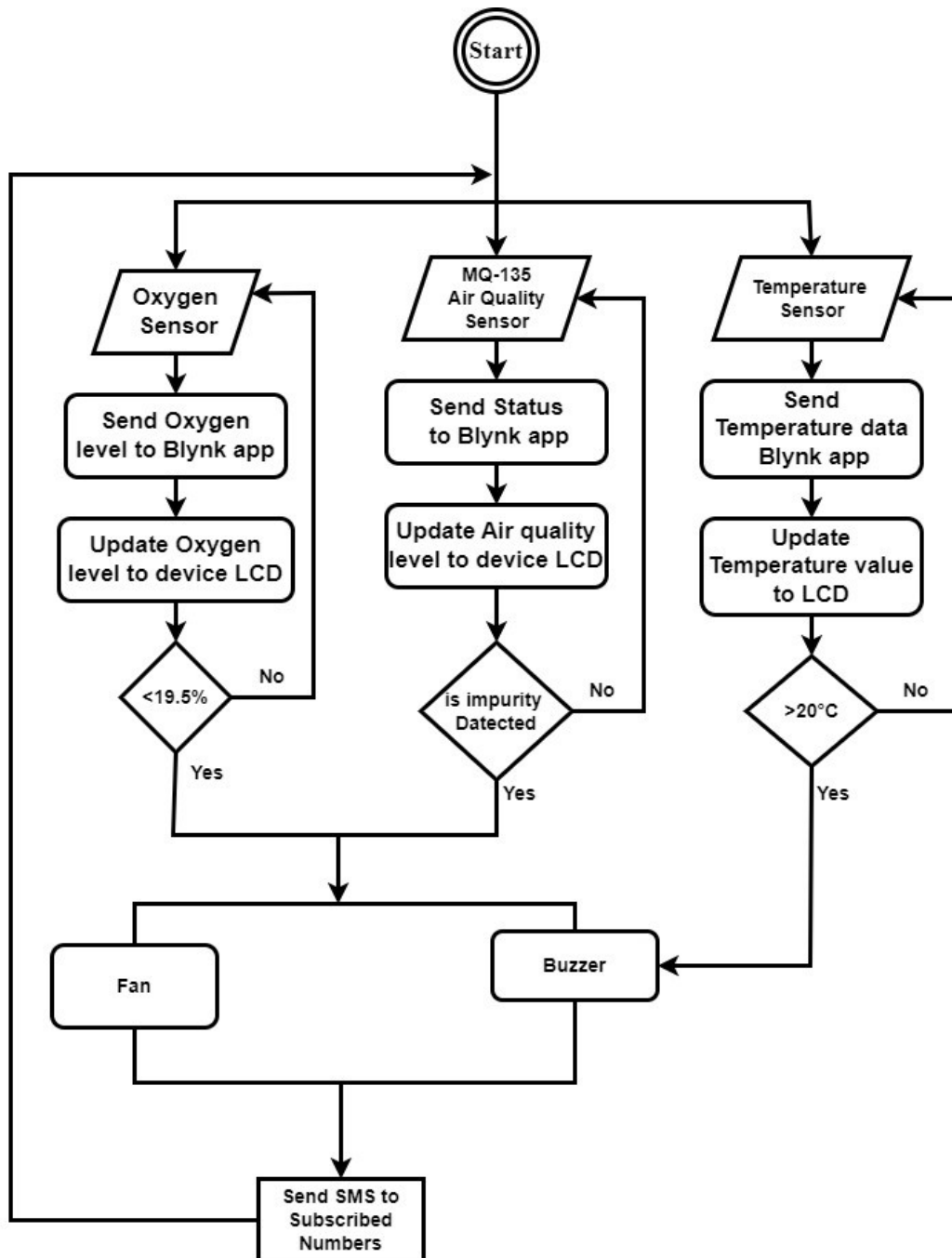

Figure 17: Developed System's Flowchart

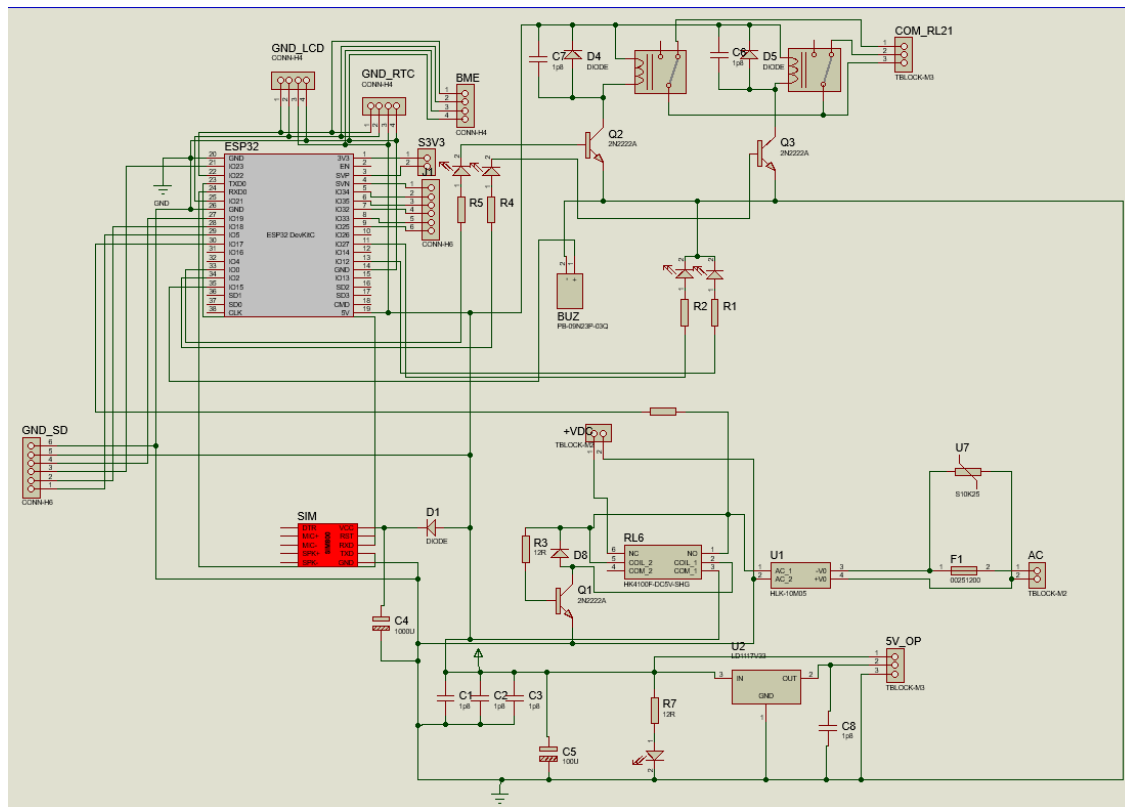

Figure 18: Developed System's Schematic Diagram

CHAPTER FOUR

RESULTS AND DISCUSSION

4.1 Results

4.1.1 Overview

The results and discussion of the developed Smart System for Monitoring and Controlling Oxygen Gas Level in High Purity Germanium Detector Room are presented in this chapter. This chapter contains a description of the analysis as well as the results obtained at various stages of the system's development and lastly a general discussion of the results. The developed system which is capable of monitoring and controlling the level of oxygen in the whole-body counter room project was designed to solve the identified existing problems as highlighted in the Chapter One. The developed prototype, collected, processed, and analyzed the level of oxygen in the room as well as information about air quality and temperature and displayed the results on the Liquid Crystal Display (LCD), and displayed the same results on the Blynk platform for virtualization and analysis. The Blynk platform enables workers to quickly access data stored on the Blynk server for analysis and decision making. This shall allow workers to monitor the levels of oxygen, air quality in the room, and temperature in real-time. The developed system provides an improved approach for minimizing the negative effects of oxygen insufficiency in Tanzania Atomic Energy Commission's whole-body counter room. The developed system was designed with the help of combining hardware, software, and written computer code in the Arduino IDE using the embedded C language.

4.1.2 Validation and Results of the Developed System

(i) Results and Discussion on Identified User Requirements

The developed system was tested (Table 3) at TAEC in the High Purity Germanium Detector Room, where a device was installed to see whether the developed system could work as expected by the end-users. System testing is a method used to test a whole integrated system. Before testing the entire system, a prior unit and integration testing activities for all components and their functionalities were performed.

Table 3: System Testing Results

Requirement	Description	Test Score
Power on the system	The system was powered and was observed	Pass
LCD	When the system was powered on, the LCD was observed	Pass
Temperature & Humidity sensor	Tested in different places and observed	Pass
Air quality sensor	It was introduced to dust and observed	Pass
Grove- gas sensor(O ₂)	The test was placed in mouth and it was observed	Pass
GSM	Tested with different SIM cards and observed	Pass
Buzzer	It was observed during Temperature & Humidity, Air quality and Grove-gas sensors	Pass

Unit Testing

Testing individual components is the process of independently testing each configurable unit before merging it into the main system. It is used to test the behavior of each sub unity before it is completely combined with the entire system.

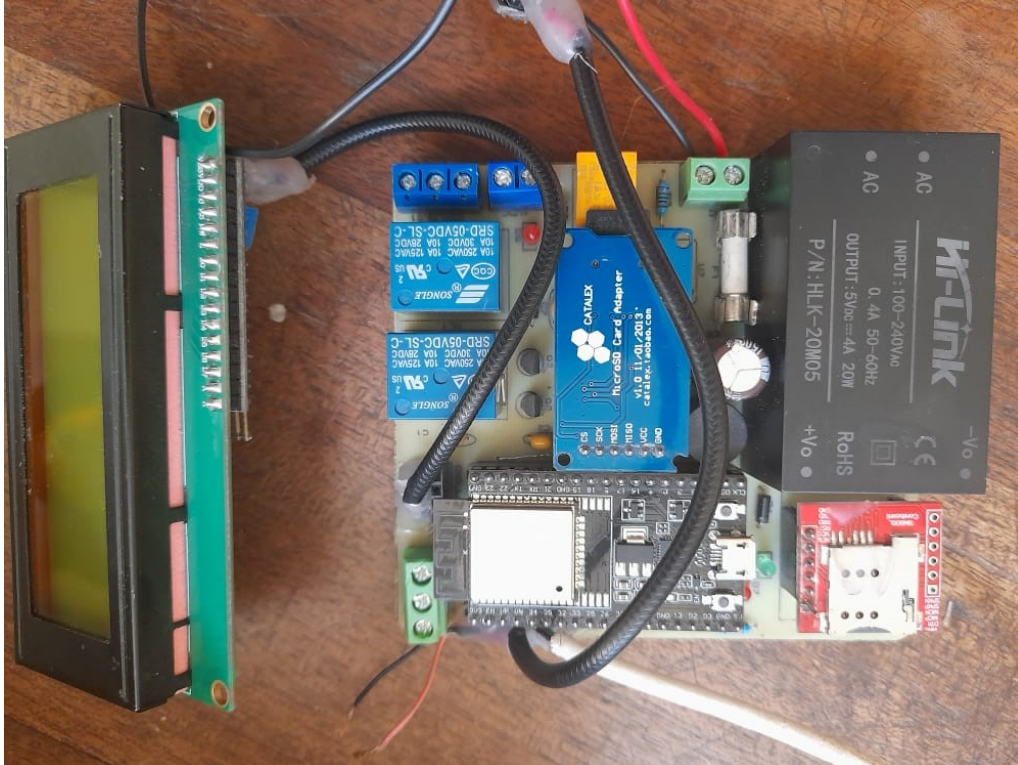

Figure 19: Testing LCD



Figure 20: Testing LCD with codes

Integration Testing

The proposed system's subsystems are integrated and tested to find out if they can communicate and interact as one complete system. This stage entailed combining various units with their associated functionality to ensure proper operation. This is the stage in which the system is deployed. Integration testing was performed by connecting all of the sensors to ensure that each sensor can monitor data appropriately. The LCD displayed all monitored data as shown in the Fig. 21.

System testing

System testing entails testing the entire system. Testing is performed on a fully functional and complete system to determine whether the system meets the precise requirements and that functions perform as expected. System testing was done by connecting all components with a Microcontroller to verify whether the developed systems met the user requirement.

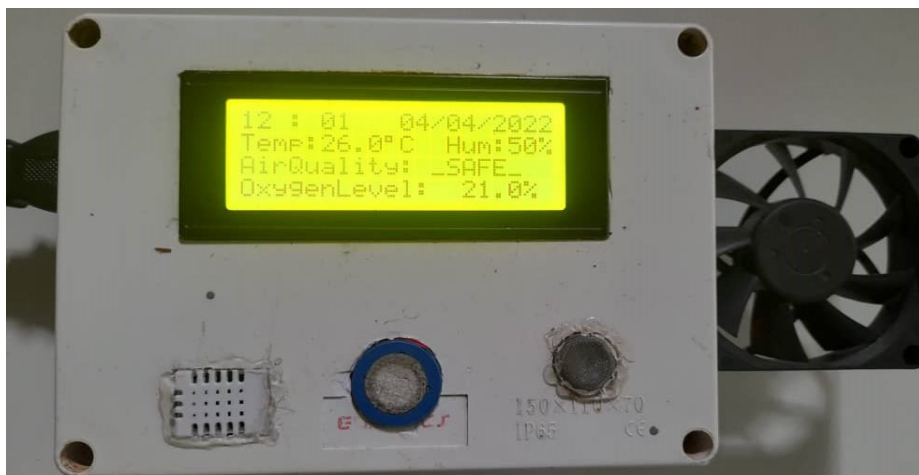

Figure 21: Testing the complete system

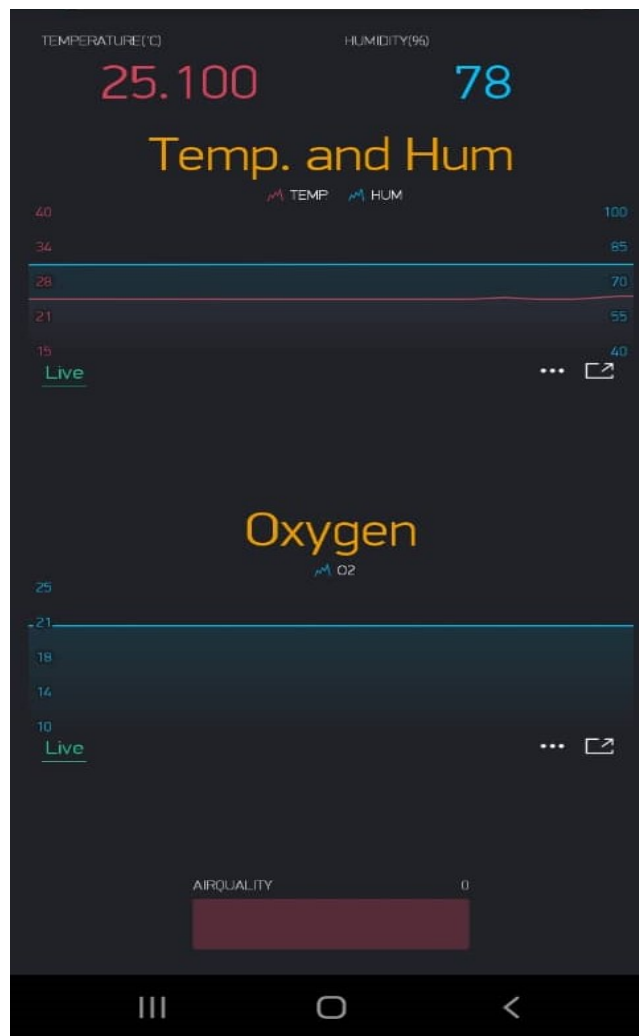

Figure 22: Complete system testing

(ii) Validation and Results of the Developed System

Validation was carried out to evaluating the system after it was developed to determine whether it satisfies the customer's expectations and requirements. It provided tangible confirmation that the system satisfies the user's expectations. During the validation phase, the system was tested to establish evidence of the intended result and to improve the system's quality.

Results on Blynk Application

With the help of Blynk Application, the levels of oxygen, air quality, and the temperature were displayed successfully. The different displays of data were shown with the help of Blynk App. The information about the data saved on the Blynk cloud server can be stored for up to a year without being destroyed and viewed at any time.

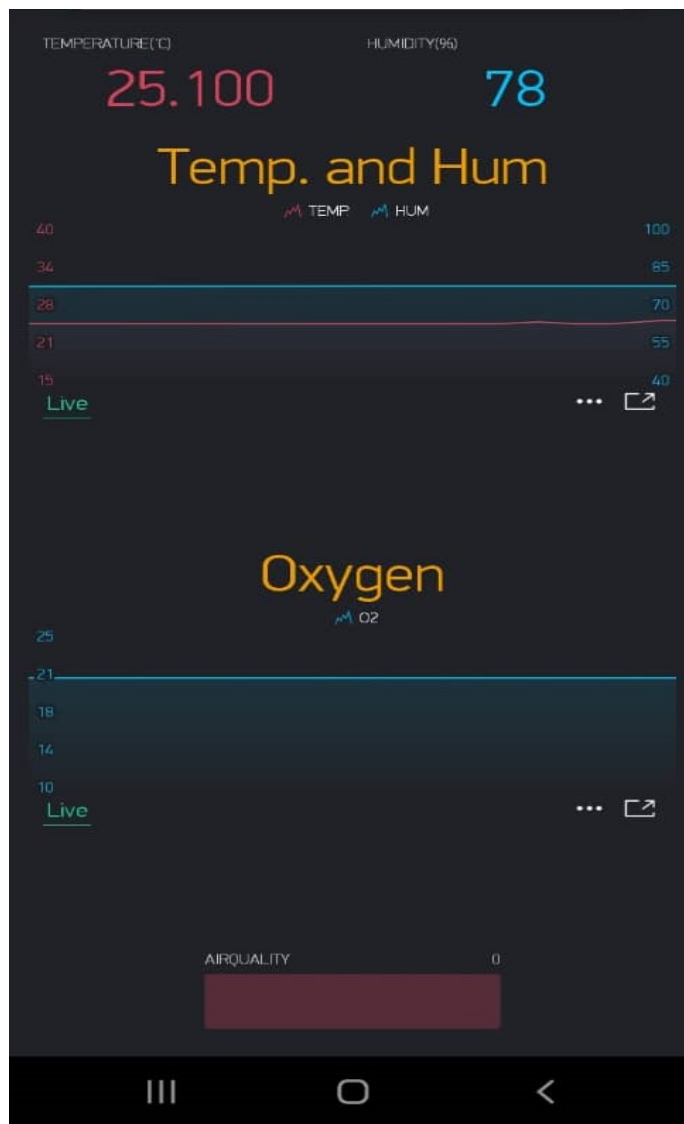

Figure 23: Blynk App with the result on safe air quality

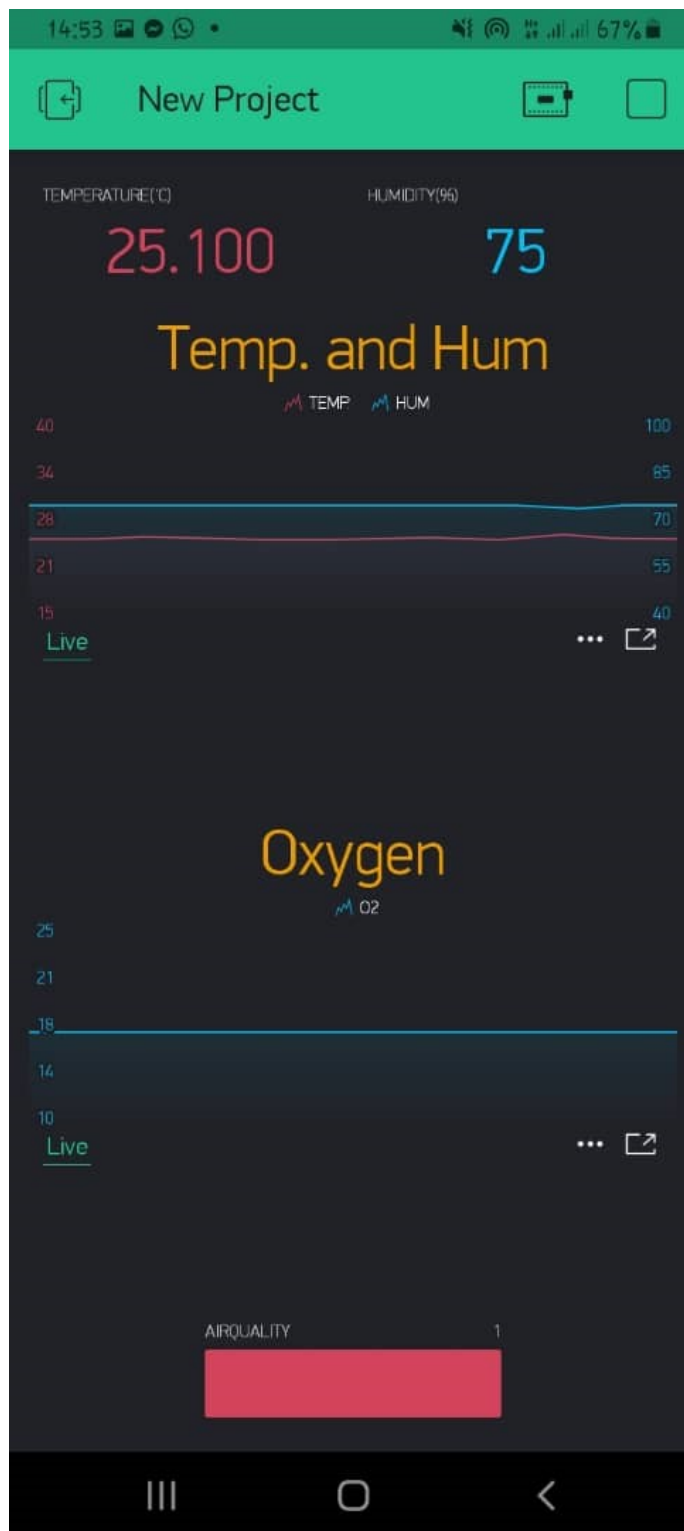

Figure 24: Blynk App with the result on unsafe air quality

Results on Liquid Crystal Display

Locally, the monitored levels of oxygen, air quality, and temperature in the room were successfully displayed on the LCD. The same results displayed on the LCD were automatically uploaded to the Blynk platform at the same time so that workers may access the room's oxygen, air quality, and temperature levels remotely before entering the room. In case oxygen level was above 19.5%, the system displayed safe while it displayed unsafe when oxygen level was below 19.5%.



Figure 25: System at off state before being switched on

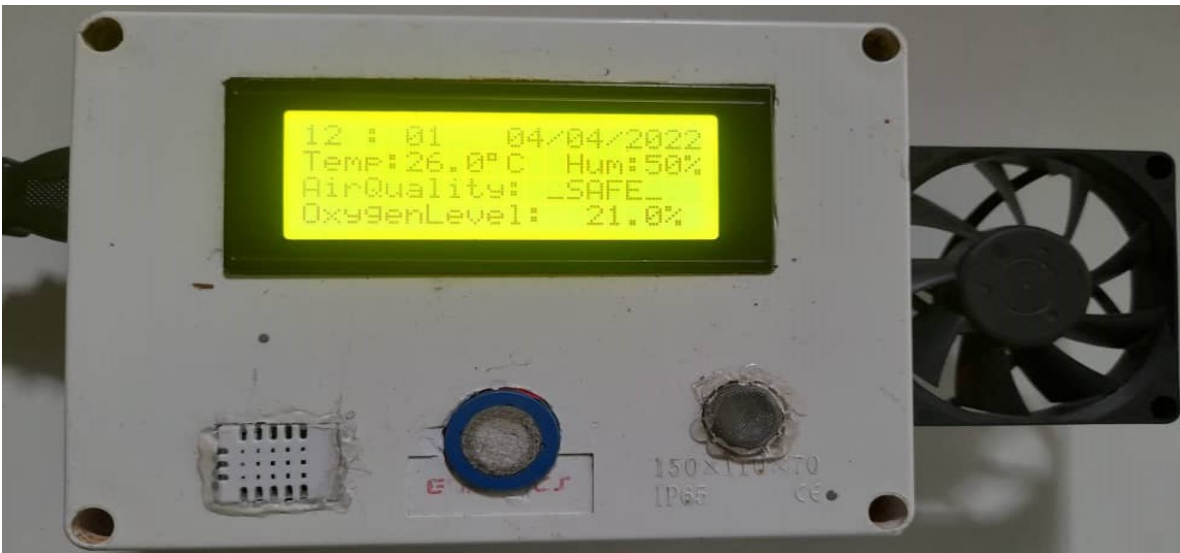

Figure 26: System displaying oxygen, air quality and temperature levels in safe mode



Figure 27: System displaying oxygen, air quality and temperature levels in unsafe mode

Results on GSM

The GSM successfully sent Short Messaging Service (SMS) to the subscribed phone number containing the information about the levels of oxygen, air quality, and temperature in the room. This would help the workers in analyzing and taking decision before entering in the room.

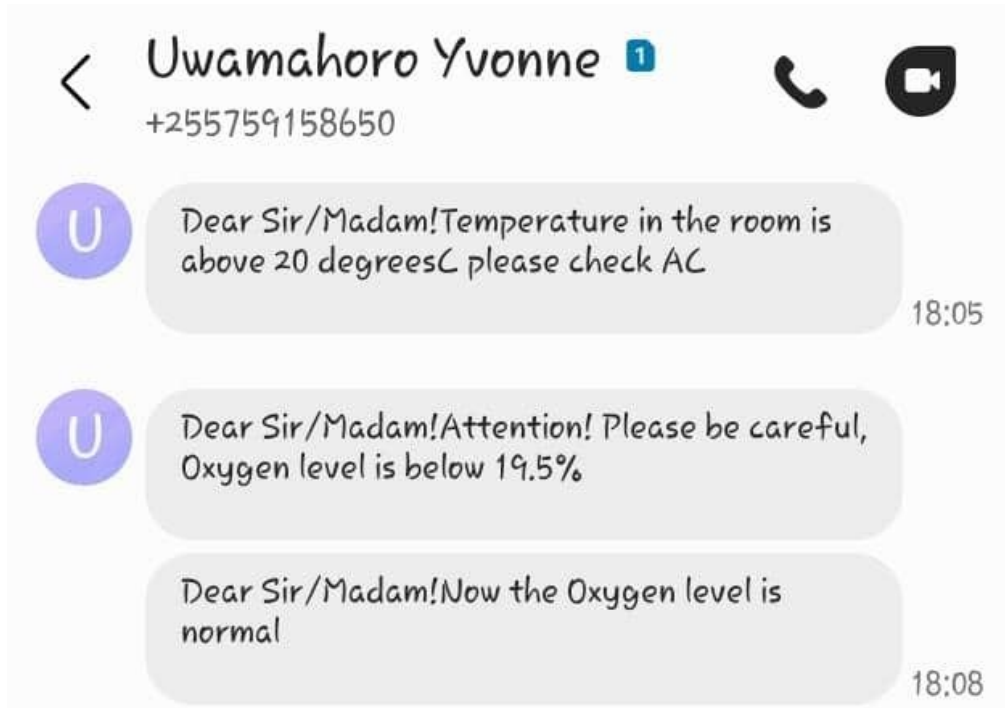

Figure 28: Showing the results through SMS

Results on Serial Monitor

When the system was tested through serial monitor, the following results were obtained as shown in Fig. 29 and Fig. 30.

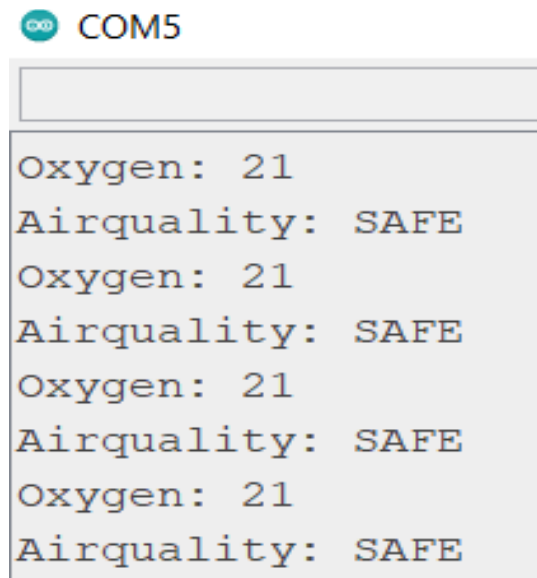

Figure 29: Results on oxygen and air quality

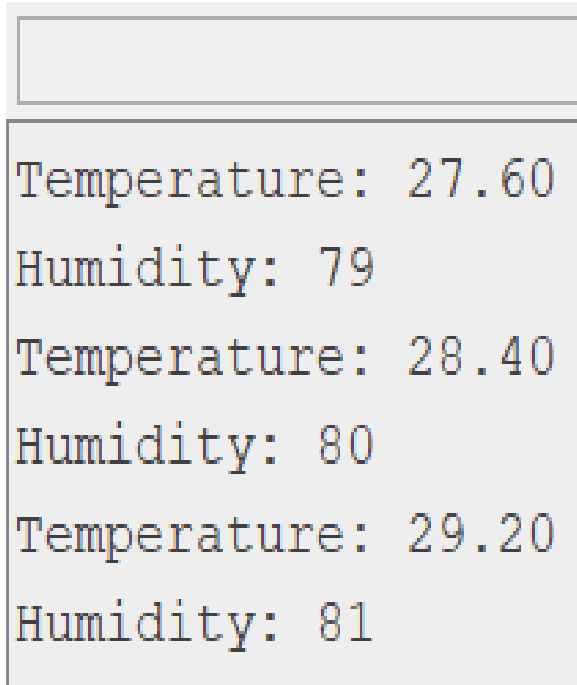

Figure 30: Results on temperature and humidity

Table 4: Functional requirements validation results

Requirements	Description	Score
Powered with DC or AC	The system should powered with DC or AC	Pass
Detect level of oxygen	The system should able to detect oxygen level in the room	Pass
Detect air quality	The system should able to detect air quality in the room	Pass
Detect temperature	The system should able to detect temperature in the room	Pass
Alert workers	The system should able to alert through the buzzer	Pass
Send SMS	The system should be able to send short message service	Pass
Availability	The system should be available every time	Pass

Table 5: Non-functional requirements validation results

Requirements	Description	Score
Update data on SD card	The system should be able to update data on SD card	Pass
User friendly	The system should to be user friendly	Pass
Acceptable and usable	The system should be acceptable and usable	Pass
Security	The system should be secured	Pass

The Chapter four contains the results obtained from the various tests carried out and the explanations referred to as discussion. This chapter clearly displays and explains what the system is designed to do and how it is going to do them.

4.2 Discussion

Through interviews, focus group discussions and observation, the real need for the development of the system for Monitoring and Controlling Oxygen Gas Level in High Purity Germanium Detector Room was correctly collected and addressed accordingly. Based on the data collected, the developed system is able to detect the levels of oxygen, temperature, humidity and other impurities and reports them accordingly as shown in Fig. 21 and Fig. 22. The system can drive away the fear that people had. Workers used to fear the impurity in the room because they could not know the level of air impurity in the room. Through the developed system, there is no more fear because the information about the levels of oxygen, temperature, humidity and air quality can be accessed remotely on smartphones as shown on Fig. 23 and Fig. 24. Moreover, there is a buzzer that can alert the workers as soon as the level of air impurity in the room increases.

The system was also validated based on functional and non-functional requirements. Tables 4 and 5 show the validation results for system functional and non-functional requirements. It is proved that the system was developed accordingly.

Through the results obtained from the developed system, it is true that the required functionalities for the proposed system to monitor and control oxygen gas level has been satisfactorily met.

The essential required steps to design and develop the system were followed which led to the complete development of the system. After testing, it is proven that the developed system meets the end-users requirements as were discussed during data collection.

CHAPTER FIVE

CONCLUSION AND RECOMMENDATIONS

5.1 Conclusion

Through identifying the user requirements for the proposed system it was possible to develop the project focused on monitoring and controlling oxygen gas level in High Purity Germanium Detector Room, at Tanzania Atomic Energy Commission [TAEC] headquarters located at Njiro, Arusha, Tanzania. We developed a system to monitor and control the level of oxygen in the High Purity Germanium detector room. We used V-Model in the project because it works well for small projects with clear requirements. It was easy to validate each step before moving on to the next level of development, resulting in the development of an error-free and high-quality system. The aim of the proposed solution was successfully achieved. The developed system provides a better solution compared to the existing system because it can monitor and control the level of oxygen, to reduce the negative effects of oxygen deficiency in the High Purity Germanium Detector Room at TAEC. The developed system is made up of four parts: The sensing component continuously monitors environmental parameters with Oxygen, MQ-135, and DHT22 sensors. The processing section processes and analyzes sensor data. The notification component alerts workers via a buzzer and Short Message Service (SMS). While the controlling component replaces the contaminated compressed air with fresh air from outside. Because of its built in Wi-Fi, The ESP32 microcontroller was used to send data to the Blynk cloud server. To implement and validate the developed system, when the system was switched on, the oxygen sensor started to sense the concentration of oxygen gas, MQ-135 sensor started to sense the air quality concentration, and the temperature sensor continuously monitored temperature in the room.

Immediate actions such as beeping of a buzzer, automatic switching on of exhaust fan were carried out and observed when there was air impurity in the room or oxygen level was low. As result, this triggered the system to send SMS to the subscribed phone numbers. The developed system can reduce the fear that causes workers to open door and windows because of liquid nitrogen leakage in the room. It can also help workers to take precaution measures in case the system alerts them of any air impurity in the room. Moreover, the system can both provide alarm and remove the oxygen-deficient air from the room by the use of an automated exhaust fan; also it can help the workers to keep safe from the effect of leaking liquid nitrogen which is the primary objective of this project to develop a Smart System for monitoring and controlling oxygen gas level in High Purity Germanium Detector Room at TAEC.

5.2 Recommendations

Every activity carried out by human beings must protect their lives. The human brain requires an ongoing flow of oxygen to stay active; without it, the brain cannot operate correctly, which eventually could lead to death. The developed system is strongly recommended for use to solve the identified issue at TAEC because it will effectively improve monitoring and controlling oxygen deficiency in the High Purity Germanium Detector Room.

There is a need to develop a customized app for the system instead of using Blynk App. The system data should be directly stored to the cloud so that it can be accessed not only on mobile phones, but any device which is connected to the internet.

REFERENCES

- Agree, N. (2013). *Re Do*. <https://scholar.google.com>
- Al Ahasan, M. A., Roy, S., Saim, A. H. M., Akter, R., & Hossain, M. Z. (2018). Arduino-Based real time air quality and pollution monitoring system. *International Journal of Innovative Research in Computer Science & Technology*, 6(4), 81-86.
- Ahmed, M. M., Banu, S., & Paul, B. (2017, December). *Real-time Air Quality Monitoring System for Bangladesh's Perspective based on Internet of Things*. In *2017 3rd International Conference on Electrical Information and Communication Technology* (pp. 1-5). <https://scholar.google.com>
- AIGA. (2008). *Hazards of Inert Gases and Oxygen Depletion*. Asia Industrial Gases Association. <https://scholar.google.com>
- Anon. (2021). *Recent Nitrogen Fatalities: Are a Vivid Reminder: Process Safety Beacon*, 2021. <https://scholar.google.com>
- Cryogen, G. (2008). *Awareness of Oxygen Depletion*. <https://scholar.google.com>
- Dararutana, C., & Abdullah, N. (2021). Calibration of whole body counter for assessment of internal dose in the human body. *Journal of Physics: Conference Series*, 1719(1), 012044.
- Documents, R. (2003). *CS2Ah0405-SoftwareRequirements*. <https://scholar.google.com>
- Edt, A. M. (2020). *DHT11, DHT22 and AM2302 Sensors*. <https://scholar.google.com>
- Enas, E. (2014). *Introduction to Proteus*. <https://scholar.google.com>
- Gill, J. R., Ely, S. F., & Hua, Z. (2002). Environmental gas displacement: Three accidental deaths in the workplace. *The American Journal of Forensic Medicine and Pathology*, 23(1), 26-30.
- Glasgow, U. O. (2010). *Safety & Environmental Protection Services Guidance Note: Environmental Protection Services*. <https://scholar.google.com>
- Green, P., Gas, I., & Applications, G. (2019). *Breathe Safely When Generating Nitrogen Guidelines for a Safe Working Environment*. <https://scholar.google.com>
- Gupta, K., Krishna, G. G., & Anjali, T. (2020, July). *An Iot Based System for Domestic Air Quality*

Monitoring and Cooking Gas Leak Detection for a Safer Home. In 2020 International Conference on Communication and Signal Processing (pp. 0705-0709). <https://scholar.google.com>

Headlines, M., Safely, W., & Lifestyle, Y. H. (2014). *How Dangerous is Liquid Nitrogen ? Drivers are Reminded to Adjust the Headrest.* <https://scholar.google.com>

Jayasree, B., Subash, T., Priyadharsan, V., Priya, N., & Students, U. G. (2021). Implementation and Measurement of IOT Based Indoor Air Quality Monitoring System. *International Journal of Scientific Development and Research*, 6(4), 372–376. www.ijedr.org

Jb, M., Ae, Y., & Birthmarks, V. (2021). *References 1.* <https://scholar.google.com>

Kim, J. Y., Chu, C. H., & Shin, S. M. (2014). ISSAQ: An integrated sensing systems for real-time indoor air quality monitoring. *Sensors Journal*, 14(12), 4230–4244.

Kodali, R. K., & Rajanarayanan, S. C. (2019). *IoT based Indoor Air Quality Monitoring System. The 2019 International Conference on Wireless Communications, Signal Processing and Networking.* <https://scholar.google.com>

Lo Faro, A. F., Pirani, F., Paratore, A., Tagliabracci, A., & Busardò, F. P. (2019). Fatal inhalation of nitrogen inside a closed environment: Toxicological issues about the cause of death. *Forensic Science International*, 302, 109871.

Maloney, M. S. (2012). Asphyxiation. *Death Scene Investigation Procedural Guide.* <https://scholar.google.com>

Moharana, B. K., Anand, P., Kumar, S., & Kodali, P. (2020). *Development of an IoT-based Real-Time Air Quality Monitoring Device.* <https://scholar.google.com>

New Jersey Department of Health and Senior Services. (1999). *Phenylenediamine.* <https://scholar.google.com>

Nitrogen, L. (2014). *Report of Liquid Nitrogen.* <https://scholar.google.com>

Rhonnell, S. P., & Carino, I. (2019). LPG Leakage Detector using Arduino with SMS Alert and Sound Alarm. *International Journal of Innovative Technology and Exploring Engineering*, 8(6C2), 221-225.

Practice, G. C., Good, E., & Practice, C. (2005). *Health & Safety Guidance Good Chemical Practice and Enhanced Good Chemical Practice.* <https://scholar.google.com>

- Resch, G. (2014). *Cryogen Safety*. <https://scholar.google.com>
- Sudio. (2022). *Grove - Gas Sensor (O₂)*. <https://scholar.google.com>
- Enigella, S. R., & Shahnasser, H. (2018). *Real Time Air Quality Monitoring*. In *2018 10th International Conference on Knowledge and Smart Technology (KST)* (pp. 182-185). <https://scholar.google.com>
- Sharma, M. P., & Parveen-Kantha, M. (2020). “Blynk” Cloud Server based Monitoring and Control using “NodeMCU.” *International Research Journal of Engineering and Technology*, 2020, 1362–1366. www.irjet.net
- Siddharthan, T. (2016). *Detection of Toxic Gases using Arduino and GSM Network*. <https://scholar.google.com>
- Stephen, O., & Oriaku, K. (2014). Software Development Methodologies: Agile Model Vs V-Model. *International Journal of Engineering and Technical Research*, 2(11), 108–113.
- Systems, I. (2017). *Lifecycle of a Development Process*. <https://scholar.google.com>
- Tr, F. Ç., & Aksay, E. (2012). Asphyxia due to accidental nitrogen gas inhalation: A case report. *Hong Kong Journal of Emergency Medicine*, 19(1), 46–48.
- Wallace, S. J. (2004). *Hazards of Nitrogen Asphyxiation*. OnePetro. <https://scholar.google.com>
- Weik, M. H. (2000). *Requirements Specification*. *Computer Science and Communications Dictionary*. <https://scholar.google.com>
- Yanisko, P., & Croll, D. (2012). *Use nitrogen safely*. *Chemical Engineering Progress*. <https://scholar.google.com>

APPENDICES

Appendix 1: Program Source Codes

```
#include <LiquidCrystal_I2C.h>
#include <Wire.h>
#include "DHT.h"
#include <WiFi.h>
#include <WiFiClient.h>
#include <BlynkSimpleEsp32.h>
#include <TimeLib.h>
#include <RTCLib.h>
#include <SPI.h>
#include <SD.h>

#define exhaustFan 2
#define Buzzer 15
#define DHTPIN 33
#define vSensor 17
#define DHTTYPE 22
#define chipSelect 5
#define REPORTING_PERIOD_MS 5000
#define beepingTime 5000

float Temp;
int Hum,oxygenLevel,airQuality,Alarm=0,col,N2Tm=0,TempTm=0;
bool Mains,nwConnect=false;

const char ssid[] = {"yvonne"};
const char pasword[] = {"12341234"};
char auth[] = "0xvKGafzWyjrr0y3zaxsKPjzBblyQIaT";
unsigned long previousMillis=0,previousMillis1=0,currentMillis;

LiquidCrystal_I2C lcd(0x27, 20, 4);// LCD I2C
```

```

BlynkTimer timer;
RTC_DS1307 Rtc;
DHT dht(DHTPIN, DHTTYPE);

void setup() {
//configuration
  pinMode(o2Sensor, INPUT);
  pinMode(vSensor, INPUT);
  pinMode(exhaustFan, OUTPUT);
  pinMode(Buzzer, OUTPUT);
  lcd.begin();
  lcd.home();
  dht.begin();
  Rtc.begin();
  Serial.begin(9600);
  timer.setInterval(2000L, sendData);
  Wire.begin();
  SD.begin(chipSelect);
  delay(10);

//initial display on LCD
  connectclient();
  lcd.setCursor(6,2); lcd.print("***TAEC***");
  lcd.setCursor(0,3); lcd.print("OXYGEN LEVEL MONITOR");
  delay(5000);
  lcd.clear(); // clear the initial display
  Blynk.config(auth);
}

//main cycle
void loop() {
//Sensor read and quantization

```

```

Hum = dht.readHumidity();
Temp = dht.readTemperature();
oxygenLevel=map(analogRead(o2Sensor),0,4095,10,21);
Mains=digitalRead(vSensor);
Display();
//LOGIC Control
airQuality=1; oxygenLevel=17;
if(Temp>20){
    digitalWrite(coolingFan,HIGH);
    Alarm=1;
    TempTm=1;
    SendSms("Temperature in the room is above 20 degreesC check AC");
}else{
    if(TempTm==1) delay(3000);
    TempTm=0;
    digitalWrite(coolingFan,LOW);
    if(Alarm==0)
        Alarm=0;
}
if(oxygenLevel<19.5||airQuality<30){
    digitalWrite(exhaustFan,HIGH);
    Alarm=2;
    N2Tm=1;
    SendSms("Attention, Oxygen level is below normal");
}else{
    if(N2Tm==1) delay(3000);
    N2Tm=0;
    digitalWrite(exhaustFan,LOW);
    if(Alarm==0)
        Alarm=0;
}

```

```

//Saving Data On SD card

currentMillis=millis();

if (currentMillis - previousMillis > REPORTING_PERIOD_MS){

  DateTime now = Rtc.now();

  File dataFile = SD.open("Data.txt", FILE_WRITE);

  if(dataFile){

    dataFile.print("Date/Time: ");

    dataFile.print(now.day()); dataFile.print('/'); dataFile.print(now.month());
dataFile.print('/'); dataFile.print(now.year());

    dataFile.print(" "); dataFile.print(now.hour()); dataFile.print(':');
dataFile.println(now.minute());

    dataFile.print("Rh: "); dataFile.print(Hum); dataFile.println('%');

    dataFile.print("Temp: "); dataFile.print(Temp,1); dataFile.println("C");

    dataFile.print("NO2: "); dataFile.print(airQuality); dataFile.println('%');

    dataFile.print("O2: "); dataFile.print(oxygenLevel); dataFile.println('%');

    dataFile.close();

  }

  previousMillis = currentMillis;

}

//Beeping

if (currentMillis - previousMillis1 > beepingTime){

  if(Alarm){

    Beep(); Beep(); Beep();

  }previousMillis1 = currentMillis;

}

//Blynk run

Blynk.run();

timer.run();

delay(500);

}

```

```

void Beep(){
  digitalWrite(Buzzer,HIGH);
  delay(70);
  digitalWrite(Buzzer,LOW);
  delay(70);
}

```

```

void sendData(){
  Blynk.virtualWrite(V1, Temp);
  Blynk.virtualWrite(V2, Hum);
  Blynk.virtualWrite(V3, oxygenLevel);
  Blynk.virtualWrite(V4, airQuality);
  if(Mains)
    Blynk.virtualWrite(V5, 1);
  else
    Blynk.virtualWrite(V5, 0);
}

```

```

void connectclient(){
//Network connect
  lcd.setCursor(0,0);
  lcd.print("CONNECTING...");
  delay(2000);
  WiFi.begin(ssid, pasword); // Attempt to connect to wifi with our password
  while(WiFi.status() != WL_CONNECTED){
    lcd.setCursor(col,1);
    lcd.print('.');
    if(WiFi.status() == WL_CONNECTED)
      nwConnect=1;
    if(nwConnect==1) break;
    WiFi.begin(ssid, pasword);

```

```

    col++;
    if(col>=19) break;
    delay(200);
}
Blynk.config(auth);
if(nwConnect==false){
    Beep();Beep();Beep();
} //ssid network connect
}

void Display(){
//Data Display
    DateTime now = Rtc.now();
    lcd.setCursor(0, 0);
    if(now.hour()<10) lcd.print('0');
    lcd.print(now.hour(),DEC);
    lcd.print(" : ");
    lcd.setCursor(5, 0);
    if(now.minute()<10) lcd.print('0');
    lcd.print(now.minute(),DEC);
    lcd.setCursor(10, 0);
    if(now.day()<10) lcd.print('0');
    lcd.print(now.day(),DEC); lcd.print('/');
    lcd.setCursor(13, 0);
    if(now.month()<9) lcd.print('0');
    lcd.print(now.month(),DEC); lcd.print('/');
    lcd.print(now.year(),DEC);
    lcd.setCursor(0,1);
    lcd.print("Temp:");
    lcd.print(Temp,1);
    lcd.print(char(223));
    lcd.print('C');

```

```

lcd.setCursor(13,1);
lcd.print("Hum:");
lcd.print(Hum);
lcd.print("%");

lcd.setCursor(0,2);
lcd.print("AirQuality:");
lcd.setCursor(12,2);
//if(airQuality<30
  // lcd.print("_SAFE_ ");
//else
  lcd.print("UNSAFE!");
lcd.setCursor(0,3);
lcd.print("OxygenLevel:");
lcd.setCursor(14,3);
lcd.print(oxygenLevel);
lcd.setCursor(16,3);
lcd.print("%");
}
void SendSms(String message){
  Serial.println("AT+CMGF=1"); //To send SMS in Text Mode
  delay(100);
  Serial.println("AT+CMGS=\"+255759158650\"\\r");
  delay(100);
  Serial.print("Dear Sir/Madam!");
  Serial.println(message);
  delay(300);
  Serial.println((char)26); //the stopping character
  delay(300);
} //SMS *

```

RESEARCH OUTPUTS

Poster Presentation



Smart System for Monitoring and Controlling Oxygen Gas Level in High Purity Germanium Detector Room

Yvonne Uwamahoro, Dr. Devatha Nyambo, Dr. Anael Sam and Eng. John Ben Ngatunga
The Nelson Mandela African Institution of Science and Technology, P.O. Box 447 Arusha Tanzania and
Tanzania Atomic Energy Commission, P.O. Box 743, Arusha Tanzania
uwamahoroy@nm-aist.ac.tz, devotha.nyambo@nm-aist.ac.tz, anael.sam@nm-aist.ac.tz, john.ngatunga@taec.go.tz



INTRODUCTION

- ❖ The only gas that sustains life is Oxygen. Approximately 21% Oxygen by volume in the air typical considered safe to breathe. If the concentration of Oxygen falls below 19.5% or rises above 23.5%, the atmosphere becomes dangerous.
- ❖ Human brain requires an ongoing flow of Oxygen to stay active; without it, the brain cannot operate correctly, which eventually could lead to death.
- ❖ This system is designed to monitor the level of Oxygen in the room.

DEVELOPED SYSTEM BLOCK DIAGRAM

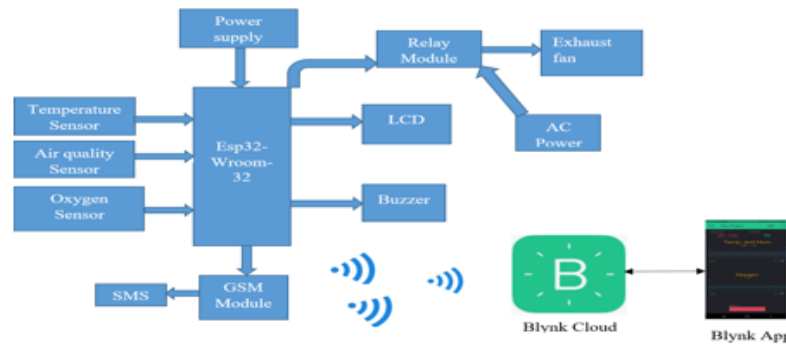

PROBLEM STATEMENT

- ❖ Evaporation of liquid Nitrogen that cannot be detected by the sense of smell or sight because it is colorless, odorless and tasteless. It is dangerous because it displaces Oxygen in the room.
- ❖ For the fear of Oxygen deficiency in the room, workers open the door and windows as the only way to prevent themselves from the danger of air impurity.
- ❖ No one can know the level of Oxygen gas in the room because the room does not have any device installed to monitor and control the level of Oxygen gas.

THE DEVELOPED SYSTEM PROTOTYPE



OBJECTIVES

MAIN OBJECTIVE

The main objective is to develop a Smart System for Monitoring and Controlling Oxygen Gas Level in High Purity Germanium Detector Room for TAEC.

SPECIFIC OBJECTIVES

- To identify the user requirements of the proposed system
- To design and develop the proposed system
- To validate and implement the proposed system

CONCLUSION

- ❖ Developed system provides a better solution for monitoring and controlling Oxygen gas, air quality and temperature levels to reduce the negative effects of Oxygen deficiency in the whole body counter room.
- ❖ It will also help workers to take precaution measures in case the system alerts them of any air impurity in the room
- ❖ The system will both provide alarm and remove the Oxygen-deficient air from the room by the use of an automated exhaust fan.