

2023-07

Real-time IoT-based air quality monitoring and health hazards indicator system for mines regions: a case study of Bulyanhulu gold mine

Flavian, Daudi

NM-AIST

<https://doi.org/10.58694/20.500.12479/2567>

Provided with love from The Nelson Mandela African Institution of Science and Technology

**REAL-TIME IOT-BASED AIR QUALITY MONITORING AND
HEALTH HAZARDS INDICATOR SYSTEM FOR MINES REGIONS: A
CASE STUDY OF BULYANHULU GOLD MINE**

Daudi Flavian

**A Project Report Submitted in Partial Fulfillment of the Requirements of the Award of
the Degree of Master of Science in Embedded and Mobile Systems of the Nelson
Mandela African Institution of Science and Technology**

Arusha, Tanzania

July, 2023

ABSTRACT

Air quality in mining regions is a significant concern due to the potential release of pollutants from mining activities and associated processes. The proximity of mining operations to communities can have detrimental effects on the air quality and pose health risks to residents. Despite the well-known harmful effects of breathing in contaminated air, yet, this concern is commonly neglected due to a lack of information regarding air quality and levels of air quality. The study indicates that the concentration of pollutants such as PM_{2.5}/PM₁₀, CO, CO₂, SO₂, and NO₂ can lead to developing chronic diseases such as respiratory issues, coughs, asthma, ischemic heart diseases, and cancer; due to inhaling hazardous air. This study proposes a real-time IoT-based air quality monitoring and health hazards indicator system for mining regions. The study implements a reliable and long-range (LoRa) wireless sensing system that collects real-time air quality data and updates it to the cloud. The developed real-time IoT-based air quality monitoring system for mines region is composed of numerous sensors (MQ7, MQ135, MQ136, MiCS4514, PMS7003, DHT22), Raspberry Pi, ATmega328 microcontroller, LoRa shields, and the ThingSpeak IoT server. The system collects air pollutants such as carbon monoxide (CO), carbon dioxide (CO₂), sulfur dioxide (SO₂), particulate matter (PM_{2.5}/PM₁₀), nitrogen dioxide (NO₂), temperature, and related humidity. The system is self-contained, using a solar charger shield to link a photovoltaic solar panel to a rechargeable battery for continuous operation. The smart sensing device constantly monitors air quality and uploads the results to a cloud via the coordinator node and the LoRa gateway shield, which in turn uploads the information to the ThingSpeak IoT server. The data collected are processed to calculate the Air Quality Index (AQI), which is then analyzed to generate early warnings and an indication of diseases and dangerous health hazards when exposed to such environments for a certain time. The results are displayed on a developed web-based dashboard that users can easily access and visualize the results. The system is very reliable as developed to simplify the monitoring process and provide accurate data on pollutant levels. The system helps environmental stakeholders in the air quality data aggregation, analysis, Air Quality Index (AQI) calculation, Reporting, and easy way of air quality data communication to the public as well as the indication of health hazards, allowing for informed decision-making, policy formulation, and mitigation strategies.

DECLARATION

I, Daudi Flavian, do hereby declare to the Senate of the Nelson Mandela African Institution of Science and Technology that this project proposal is my original work and that it has neither been submitted nor being concurrently submitted for degree award in any other institution.

Daudi Flavian

Name of Candidate

Signature

Date

The above declaration is confirmed by:

Prof. Michael Kisangiri

Name of Supervisor 1

Signature

Date

Dr. Ramadhani Sindi

Name of Supervisor 2

Signature

Date

COPYRIGHT

This project is a copyright material protected under the Berne Convention, the Copyright Act of 1999 and other International and National enactments, on that behalf, an intellectual property. It may not be reproduced by any means, in full or in part, except for short extracts in fair dealing, for research or private study, critical scholarly review, or discourse with an acknowledgment, without a written permission of the Deputy Vice Chancellor for Academic, Research, and Innovation, on behalf of both the author and the Nelson Mandela African Institution of Science and Technology.

CERTIFICATION

The undersigned certify that they have read and, with this recommendation for acceptance by the Nelson Mandela African Institution of Science and Technology, a project report titled, *“Real-Time IoT-Based Air Quality Monitoring and Health Hazards Indicator System for Mines Regions: A Case Study of Bulyanhulu Gold Mine”* in partial fulfilment of the requirements for the degree of Master of Science in Embedded and Mobile Systems of the Nelson Mandela African Institution of Science and Technology.

Prof. Michael Kisangiri

Name of Supervisor 1

Signature

Date

Dr. Ramadhani Sindi

Name of Supervisor 2

Signature

Date

ACKNOWLEDGEMENTS

I would like to express my gratitude to the Almighty God in a very particular way for his grace, protection, strength, knowledge, power, and courage that helped me complete the courses and final project work for this Master's degree program. The Centre of Excellence for Information and Communication Technology in East Africa (CENIT@EA) deserves my deepest gratitude for providing financing support throughout my Master's degree studies and supporting this final project work.

My deepest gratitude goes out to all of the faculty and staff at the Nelson Mandela African Institution of Science and Technology (NM-AIST), especially those in the School of Computational and Communication Science and Engineering, for their guidance and full support during the entire study life at NM-AIST.

Last but not least, I would like to appreciate the full support from my industrial supervisor Eng. Daniel Murenzi and the entire team of the East Africa Community (EAC) secretariat.

Finally, I also express my gratitude to my classmates from six EAC countries, it was an amazing class full of love and support.

DEDICATION

I dedicate this work to my parents and my family for their support and for always believing in me.

TABLE OF CONTENTS

ABSTRACT.....	i
DECLARATION	ii
COPYRIGHT.....	iii
CERTIFICATION	iv
ACKNOWLEDGEMENTS	v
DEDICATION	vi
TABLE OF CONTENTS.....	vii
LIST OF TABLES.....	xi
LIST OF FIGURES	xii
LIST OF APPENDICES.....	xiii
LIST OF ABBREVIATIONS AND SYMBOLS	xiv
CHAPTER ONE	1
INTRODUCTION	1
1.1 Background of the Problem	1
1.2 Statement of the Problem.....	4
1.3 Rationale of the Study.....	5
1.4 Project Objectives	6
1.4.1 General Objective.....	6
1.4.2 Specific Objectives.....	6
1.5 Research Questions.....	6
1.6 Significance of the Project.....	7
1.7 Delineation of the Study	7
CHAPTER TWO	9
LITERATURE REVIEW	9
2.1 Global Air Quality Concentrations and Trends	9

2.2	Tanzania Air Quality Concentrations and Trends	10
2.3	Roles and responsibilities in addressing Air Pollution in Tanzania	10
2.4	Disease and Economic Burden	11
2.5	Air Quality Case Statistics in Tanzania	12
2.6	Advantages of Integrating IoT for Air Quality Monitoring.....	12
2.7	Empirical Literature Review.....	13
2.8	Literature Review Observations	15
CHAPTER THREE		17
MATERIALS AND METHODS.....		17
3.1	Study Area and Scope of the Project	17
3.2	Sampling Technique	17
3.3	Data Collection Methods	18
3.3.1	Questionnaires.....	18
3.4	Data Analysis.....	19
3.5	System Development Methodology.....	19
3.6	System Modeling	20
3.6.1	Flow Chart.....	20
3.6.2	Use Case Diagram.....	22
3.6.3	Data Flow Diagram	23
3.7	Sensor Node Design.....	24
3.8	System Architecture Design	27
3.9	Hardware and Software Components	28
3.9.1	Software Components	28
3.9.2	Hardware Components.....	30
3.10	Air Quality Index	35
3.10.1	Pollutant-Specific Sensitive Groups.....	36

3.10.2	Pollutant-Specific Sub-indices for Air Quality Index Guidance	37
3.10.3	Calculating the AQI.....	38
3.11	System Development	40
3.11.1	Sensing Unit	40
3.11.2	Data Processing Unit	40
3.11.3	Web Application Unit.....	40
3.12	System Testing, Validation, and Verification.....	41
3.12.1	System Testing	41
CHAPTER FOUR.....		44
RESULTS AND DISCUSSION		44
4.1	Results.....	44
4.1.1	Findings from Miners and Residents Living Near Mines Areas.....	44
4.1.2	Functional and Non-Functional Requirements for the proposed system	48
4.1.3	System Implementation Overview	50
4.1.4	Hardware Design and Implementation.....	53
4.1.5	Performance Evaluation	53
4.1.6	The Web-based System.....	54
4.1.7	Health Hazards Indication.....	58
4.1.8	System Implementation Challenges and Mitigations.....	58
4.2	Discussion	59
CHAPTER FIVE		60
CONCLUSION AND RECOMMENDATIONS		60
5.1	Conclusion	60
5.2	Recommendations.....	60
REFERENCES		61
APPENDICES		67

RESEARCH OUTPUTS.....72

LIST OF TABLES

Table 1:	Six Air Quality Index (AQI) categories.....	36
Table 2:	Pollutant-specific sensitive groups	37
Table 3:	Pollutant-Specific Sub-indices and Warning Statements for AQI Guidance	38
Table 4:	Breakpoints for the AQI	39
Table 5:	User acceptance testing results	43
Table 6:	Respondents' demographic information	45
Table 7:	Functional requirements	49
Table 8:	Non-Functional requirements	50

LIST OF FIGURES

Figure 1:	Deaths in Tanzania, attributed to ambient air quality 2012 (WHO, 2016)	12
Figure 2:	The study area map.....	17
Figure 3:	Excel CSV data file loaded into Jupyter Notebook for analysis	19
Figure 4:	Agile extreme programming software development model	20
Figure 5:	Flow chart diagram for sensor node	21
Figure 6:	Flow chart diagram for the gateway node	22
Figure 7:	System use case diagram.....	23
Figure 8:	Data flow diagram level 0	23
Figure 9:	Data flow diagram level 1	24
Figure 10:	Sensor node framework design	24
Figure 11:	Sensor node Schematic circuit design	25
Figure 12:	The 3D circuit design of the sensor node	26
Figure 13:	Printed Circuit Board layout.....	26
Figure 14:	System architecture design framework	27
Figure 15:	System architecture layout design	28
Figure 16:	Respondents' awareness of the effects of mining activities on air pollution.....	46
Figure 17:	Respondents' responses for sources of air pollution.....	46
Figure 18:	Respondents' perspectives on air quality monitoring	47
Figure 19:	Diseases people usually suffer from or contact.....	48
Figure 20:	(a) PM _{2.5} , (b) PM ₁₀ , (c) CO, (d) CO ₂ , (e) NO ₂ , (f) SO ₂ , (g) temperature and (h) humidity.....	52
Figure 21:	System physical hardware design.....	53
Figure 22:	Web-based air quality monitoring system, Login page.....	55
Figure 23:	Web-based air quality monitoring system, Registration page.....	55
Figure 24:	Web-based real-time air quality monitoring system, Dashboard page	56
Figure 25:	A web-based air quality monitoring system, Node-1 dashboard	57
Figure 26:	A web-based air quality monitoring system, Node-2 dashboard	57

LIST OF APPENDICES

Appendix 1: Poster Presentation	67
Appendix 2: Part of the Source Code	68

LIST OF ABBREVIATIONS AND SYMBOLS

AQI	Air Quality Monitoring
AQMS	Air Quality Monitoring System
AWS	Amazon Web Services
CO	Carbon Monoxide
CO ₂	Carbon Dioxide
COVID-19	Coronavirus 19
CPT	Compact Prediction Tree
CSS	Cascading Style Sheet
DFD	Data Flow Diagram
DHT	Digital Humidity and Temperature
EMA	Environment Management Act
GCLA	Government Chemist Laboratory Authority
GDP	Gross Domestic Product
GPIO	General Purpose Input/Output
HTML	Hypertext Markup Language
IDE	Integrated Development Environment
IoT	Internet of Things
LCD	Liquide Crystal Display
LoRa	Long-Range
LoRaWAN	Long Range Wide Area Network
LPWAN	Low Power Wide Area Network
LTE	Long Term Evolution
MQTT	Message Queuing Telemetry Transport
NEMC	National Environment Management Council

NO ₂	Nitrogen Dioxide
OSHA	Occupational Safety and Health Authority
PCB	Printed Circuit Board
PHP	Hypertext Preprocessor
PM	Particulate Matter
RDBMS	Relational Database Management System
RTC	Real Time Clock
SO ₂	Surfer Dioxide
SQL	Structured Query Language
TBS	Tanzania Standards Bureau
TIRDO	Tanzania Industrial Research and Development Organization
UML	Unified Modeling Language
UNICEF	Unites Nations Children's Fund
VoCS	Volatile Organic Compound
WHO	World Health Organization
WI-FI	Wireless Fidelity
XP	Extreme Programming

CHAPTER ONE

INTRODUCTION

1.1 Background of the Problem

Air quality monitoring and health hazards indicator systems play a crucial role in ensuring the well-being of individuals residing in mining regions. Mining activities have a significant impact on the surrounding environment, leading to the release of various pollutants and hazardous gases into the air. These pollutants can have detrimental effects on both the environment and human health (Choiri *et al.*, 2021).

The proximity of mining operations near residential areas further increases the risk of exposure to these pollutant for local communities (Kampa & Castanas, 2008).

People are aware of the negative consequences that might result from breathing in filthy air; nevertheless, this worry is frequently disregarded since there is typically a lack of information regarding the air quality as well as the levels of air quality. During the Coronavirus 19 (COVID-19) pandemic, the importance of the air quality in the surrounding area has increased, which suggests that the Air Quality Index (AQI) must be assessed immediately in real-time though many different methods for monitoring air quality have been suggested in, the vast majority of them make use of the emerging technology known as the Internet of Things (IoT) to deliver information in real-time about their environments (Chandra *et al.*, 2021). No question enhancing the quality of the air has a beneficial effect on the health of individuals. When there is a lack of cleanliness in the air, there are negative effects on both public health and the economy.

The term "air pollution" refers to the contamination of an indoor or outdoor environment by any chemical, physical, or biological substance that affects the inherent features of the atmosphere. The degree to which the air is unpolluted or tainted with pollutants is referred to as "Air Quality" (World Health Organization, 2016). Monitoring the quality of air entails detecting pollutant concentrations in the air over time.

Air quality control is a critical problem at both international and national levels to ensure the health and safe living of people and the environment. The majority of pollutants in the air are caused by emissions from machinery, automobiles, trucks, factories, power plants, fire, mining

activities, and other industrial and human activities (World Health Organization, 2020). People are exposed to a variety of health risks when they breathe in contaminated air.

Exposure to air pollution might cause adverse effects on human health such as breathing problems, coughing, lung damage, cancer, asthma, reproductive systems damage, premature death, bronchitis, or cause lung cancer. Additionally, it may result in damage to the cardiovascular system, irritate the eyes, nose, and throat, increased susceptibility to infections, and redness or swelling of the lung tissue (Chen & Hoek, 2020; Huangfu & Atkinson, 2020; Orellano *et al.*, 2020, 2021; Zheng *et al.*, 2021).

According to World Health Organization (2021), major Air pollutants include carbon monoxide (CO), carbon dioxide (CO₂), sulfur dioxide (SO₂), particulate matter (PM_{2.5}/PM₁₀), and nitrogen dioxide (NO₂).

Particulate matter (PM) is a suspension in the air comprising a combination of liquid droplets and solid particles, many of which are hazardous (Orellano *et al.*, 2020).

Particulate matter (PM) is classified into two primary categories based on its size, the larger PM₁₀ (2.5 to 10 micrometers) is mostly made up of dirt, dust, and smoke from mining activities, construction sites, wildfires. While PM_{2.5} also referred to as fine particulate matter is considered to be smaller in size than 2.5 micrometers and made up of oil, diesel fuel, gasoline, metals, and hazardous organic compounds from metal processing and automobiles.

Particulate Matter 2.5 (PM_{2.5}), due to its smaller weight, may remain in the air for long periods and travel farther than PM₁₀. When we inhale air, any particles in the air are ingested as well and quickly enter the respiratory system. Because PM_{2.5} is composed of more harmful substances such as carcinogenic organic compounds and heavy metals, it may have a greater detrimental effect on health than the larger PM₁₀. Particulate matter exposure causes Asthma, coughing, wheezing, respiratory and cardiovascular (ischemic heart) disease, cerebrovascular (stroke), and even lung cancer (Chen & Hoek, 2020; Orellano *et al.*, 2020).

Carbon monoxide (CO) is a poisonous, odorless, and colorless gas formed when fuels (such as petrol, kerosene, wood, charcoal, and natural gas) are burned inefficiently. When humans get inhale this gas, it prevents oxygen from reaching the brain and heart and causes a reduction in the oxygen-carrying capacity of the blood. Carbon monoxide exposure can lead to death in extreme cases (World Health Organization, 2021).

Sulfur dioxide (SO₂) is mostly emitted into the air when fossil fuels are burned (burning sulfur-containing fuels like diesel) in power plants, mining, and industrial activities such as metal extraction from ore, and motor vehicles run on high sulfur fuel. Sulfur dioxide exacerbates asthma symptoms and makes breathing more difficult (Orellano *et al.*, 2021).

Nitrogen dioxide (NO₂), has a brownish appearance and is a powerful oxidant. Combustion activities, such as those used in heating, transportation, and the generation of power, are responsible for the production of nitrogen dioxide (NO₂). The inhalation of nitrogen dioxide might aggravate existing respiratory diseases and cause airway irritation. Nitrogen dioxide (NO₂) is a major contributor to the formation of ozone and a pollutant that has been linked to asthma and other respiratory diseases. Prolonged exposure to NO₂ pollutants can increase the risk of developing cancer, and stroke (World Health Organization, 2021).

Mines pollute the air through blasting, drilling, material handling, processing, burning, overburden loading and unloading, and transportation (Schwegler, 2006). Wind erosion may suspend waste rock and tailings from disturbed sites or waste disposal facilities. Environmental Management Plans must address these challenges. These plans typically fail to appropriately address air pollution emissions because they lack air quality data which leads to the failure to include air quality management in mine environmental planning and does not take into account possible air quality impacts (Schwegler, 2006).

In mines, air quality management must be integrated into a single plan that covers all sources, relative impacts, reduction techniques, processes, responsibilities, monitoring, and performance evaluation. This should ensure that air quality is maintained at acceptable levels at all times and under normal conditions, from mine planning to mine closure.

Monitoring air quality in mining regions is required to ascertain the area's air quality. The primary goal of monitoring air quality should be to determine how much pollution is being inhaled by the general public. Pollution around the area may affect both humans and other living organisms. Information on the exposure-reaction connection is required for evaluating potential health issues.

Public health standards, tracking pollution trends, pollutant level warnings, and generating data for policymaking and assessing environmental impacts are all purposes of air quality monitoring.

This project focuses on air quality monitoring and health hazard indicators that use sensors to detect levels of common pollutants namely carbon monoxide, carbon dioxide (CO₂), sulfur dioxide, nitrogen dioxide, and Particulate Matter. Collected data are analyzed for the identification of health hazards, and levels of pollutants around the area. The real-time results are then displayed on Liquid Crystal Display (LCD), and web page for easy remote monitoring of air quality and early alerting of health hazards. The purpose of early warning is to make residents, policymakers and researchers act promptly.

1.2 Statement of the Problem

Mines dust is frequently mistakenly believed to be chemically inert. In many cases, the amount of fine dust created by a mine, as well as the chemical and mineralogical composition makeup of the dust generated by mine frequently determine the potential for health effects.

Many miners and residents living near mines are at risk of developing chronic diseases such as respiratory issues, coughs, asthma, and cancer, due to inhaling hazardous air.

Air pollution has received a lot of attention from scientists and politicians in countries like India and China, but it has not received nearly as much attention in Africa, even though it is having a devastating effect on the continent's economy and human health. On the African continent, toxic air has been responsible for more premature deaths than contaminated water or starvation in children, while also making a substantial contribution to the current climate disaster (Roy, 2016).

According to research published by the United Nations Children' Fund (UNICEF), the number of deaths in Africa attributable to outdoor air pollution has grown by 57% in fewer than three decades, going from 164 000 in 1990 to 258 000 in 2017. This has resulted in a loss of Gross Domestic Product (GDP) of over \$215 billion yearly.

Additionally, pollution has shortened the lifespan of children by an average of 24 months (UNICEF, 2019).

More than 2000 fatalities per year can be attributed to respiratory illnesses, cardiovascular events, and strokes brought on by emissions of sulfur dioxide, particulate matter, and mercury over most of Africa (UNICEF, 2019).

Statistics in Tanzania show that the number of patients with respiratory problems and cancer is increasing (World Health Organization, 2016). This situation necessitates the need for research to identify the sources of the increase as well as the environmental and climate safety of the areas.

These have also been identified by the President of Tanzania Hon. Dr. Samia Suluhu Hassani, speaking during the Bugando Regional Referral Hospital's 50th jubilee celebrations, noted that the number of cancer patients in the lake zone had increased from 1200 in 2019 to 1500 in 2020. However, even though researchers have identified pollution in mineral water sources as a possible cause of the condition, further researches need to be done (HabariLeo, 2021).

In light of the aforementioned constraints, this project developed a real-time IoT-based air quality monitoring and health hazards indicator system for monitoring air quality in mines regions. The proposed system displays real-time data along with potential health risks associated with prolonged exposure to such an environment.

1.3 Rationale of the Study

Mining is essential for any country with mineral resources to develop economically. This is due to the economic benefits provided to countries that engage in both internal and external mineral resource extraction. These benefits include job creation, revenue generation, and countries having access to a significant amount of foreign exchange.

Several economies have recognized the economic benefits of mining, but have failed to consider the environment as well as the health effects of mining operations. Recent environmental and health studies have found that mining operations are more destructive to human health and economic development than beneficial.

As a result, numerous mining companies claim to have responded by adopting and implementing several measures aimed at reducing the harmful environmental and health consequences of their operations on the general public. It's unclear whether some of these efforts have reduced or can reduce the harmful health effects of mining on the environment and nearby communities because of the unavailability of supporting data and systems to monitor the environment and health effects in mining areas.

The development of a real-time IoT-based air quality and health hazards indicator system for monitoring air quality in mines regions helps in solving many challenges currently being faced in mines regions. This system employs sensors to identify the presence of various contaminants in the atmosphere.

In this prototype, gas sensors are used to record the concentrations of various contaminants encountered in the air daily. The real-time data gathered by the various gas sensors are stored in the cloud, and the results are analyzed to provide warning alerts on the possibility of diseases such as cough, asthma, respiratory problems, lung cancer, and so on. Furthermore, preventive recommendations are provided, which is just a cautionary message displayed on an LCD display and on the web.

1.4 Project Objectives

1.4.1 General Objective

The main objective of this project was to design and develop a real-time IoT-based air quality monitoring and health hazards indicator system for mines regions.

1.4.2 Specific Objectives

The study aimed to achieve the following specific objectives:

- (i) To identify requirements for developing a real-time IoT-based air quality monitoring and health hazards indicator system for mines regions.
- (ii) To develop a real-time IoT-based air quality monitoring and health hazards indicator system for mines regions.
- (iii) To validate the developed system.

1.5 Research Questions

The study intended to answer the following questions:

- (i) What are the essential requirements for the development of a real-time IoT-based air quality monitoring and health hazards indicator system specifically designed for mining regions?
- (ii) How can a real-time IoT-based air quality monitoring and health hazards indicator system be effectively developed and implemented for mining regions?

- (iii) What is the effectiveness and accuracy of the developed real-time IoT-based air quality monitoring and health hazards indicator system in accurately detecting and indicating air quality and health hazards in mining regions?

1.6 Significance of the Project

When it comes to the existence of all living organisms, the air is one of the most crucial ingredients. Living organisms such as humans not only need air but also need it to be clean and pollution-free. When air quality is poor, it is hazardous to health, particularly for those who are susceptible to it, such as children, the elderly, or those who have heart disease, asthma, or other respiratory problems.

Monitoring Air quality helps in analyzing pollution levels by ambient air quality standards. Robust monitoring helps protect people and environments from extreme events by alerting them and initiating actions.

The proposed solution is making contributions in the following ways:

- (i) This project helps in monitoring the quality of the air in real-time by using low-power sensors and a communication network.
- (ii) Displaying air quality data to stakeholders in real-time.
- (iii) Real-time alerts and notifications when air pollution exceeds the threshold.
- (iv) Users can access real-time data in the system remotely by using browsers on their smartphones or computers.
- (v) Data analysis for the early warning regarding health hazards. The purpose of early warning is to make residents, policymakers and researchers act promptly.

1.7 Delineation of the Study

Air quality monitoring is a broad field. This project focuses on monitoring the quality of the air in the mine's regions. This system can be implemented in any mining region in the East Africa community to detect hazardous gases and display various gas levels including PM2.5, PM10, NO₂, CO, CO₂, temperature, and related humidity as East Africa have specific environmental challenges and pollution sources that are similar. By focusing on this area, the

system can be tailored to address the unique air quality issues associated with mining activities in East Africa, such as specific hazardous gases or pollutants commonly found in mining operations.

CHAPTER TWO

LITERATURE REVIEW

2.1 Global Air Quality Concentrations and Trends

It is customary practice in the field of air quality management, evaluation of trends, and exposure estimation for epidemiological studies to take readings of pollutant concentrations in the air at monitoring stations that are permanently installed. Even though there has been a rise in the number of monitoring sites across the world, coverage is still insufficient. This means that it is often restricted to major cities, which makes it impossible to accurately estimate exposure in the various locations where people reside (World Health Organization, 2021). In global air quality concentrations and trends two significant gaps exist.

First, many countries lack monitoring, particularly in rural areas and outside large cities. The second gap is insufficient monitoring of air pollution spatial variation within cities.

The only publicly accessible worldwide databases of air quality measurements are those maintained by OpenAQ and the WHO Global Ambient Air Quality Database. The WHO Global Ambient Air Quality Database has data that may be accessed on the annual average concentrations of PM 10 and PM 2.5 for a variety of different cities. These concentrations are derived from the data that are currently available (where possible, averaging readings from many stations in a single city) (World Health Organization, 2021). The OpenAQ is an open-source project that collects and stores historical and real-time air quality data from government agencies for free (OpenAQ, 2022). While there have been progresses in both monitoring and data accessibility, many publicly supported organizations still do not make their data easily accessible.

The ambient concentrations of air pollutants have a significant impact on the likelihood of exposure. The levels of pollutants in the air can differ widely from one place to another, and even within a single region. It's worth noting that in 2019, more than 90% of the world's population was located in places where concentrations were higher than the WHO air quality guideline of 10 g/m³ (World Health Organization, 2021).

2.2 Tanzania Air Quality Concentrations and Trends

Tanzania's air quality is degraded by emissions from forest fires, solid waste, trucks, power plants, industrial operations, mining activities, inadequate waste management, construction, domestic activities, and un-tarmacked roads (HPAP, 2019).

2.3 Roles and responsibilities in addressing Air Pollution in Tanzania

The Vice President's Office - Division of Environment manages the environment, and develops environmental policy and regulations. The Minister for Environment formulates policy guidelines to promote, protect, and sustain Tanzania's environment. The National Environmental Advisory Committee advises the environment minister or any sector Ministry on environmental issues. The Director of Environment coordinates environmental activities by other agencies, encourages the inclusion of environmental factors into development policies, plans, strategies, projects, and programs, and processes or issues multiple environmental licenses (HPAP, 2019).

Other government organs help in the management and protection of the environment including:

- (i) The National Environment Management Council (NEMC) implements the 2004 Environmental Management Act (EMA). The EMA requires NEMC to enforce environmental standards (including air quality standards), compliance evaluation and monitoring of environmental effects assessments, research, public engagement in environmental decision-making, environmental awareness, and information collection and dissemination (HPAP, 2019).
- (ii) The Occupational Safety and Health Authority (OSHA) enforces the Occupational Safety and Health Act No. 5 of 2005 and advises the government on all occupational safety and health issues. It performs occupational safety and health research, consulting, and training. OSHA monitors occupational air pollution (HPAP, 2019).
- (iii) Local Government Authorities, coordinated by Environment Management Officers at City, Municipal, District, and Town levels, monitor and enforce environmental regulations, including air quality standards (HPAP, 2019).
- (iv) Tanzania Standards Bureau (TBS) sets outdoor air quality guidelines. Government Chemist Laboratory Authority (GCLA), and Tanzania Industrial Research and

Development Organization (TIRDO) monitor and test outdoor air pollutants such as SO₂, NO_x, CO, VOCs, PM₁₀, PM_{2.5}, NO, and NO₂ (HPAP, 2019).

2.4 Disease and Economic Burden

Air pollution poses the greatest threat to the environment worldwide. According to the WHO, indoor and outdoor air pollution contribute to around 7 million deaths annually, most of which are caused by Noncommunicable diseases (World Health Organization, 2021).

Similar worldwide studies of ambient air pollution alone estimate 4–9 million deaths yearly and hundreds of millions of lost healthy life years, with the largest associated disease burden found in low- and middle-income countries (Burnett *et al.*, 2018; Murray *et al.*, 2020; Vohra *et al.*, 2021; World Health Organization, 2021). All-cause mortality, bronchitis, asthma, pulmonary diseases, heart disease, lung cancer, and stroke are just some of the many diseases that have been linked to air pollution exposure (Cohen *et al.*, 2017; World Health Organization, 2021). Low birth weight and premature birth have been linked to an increased risk of newborn death, and a growing body of data supports a direct linkage between the two conditions (Murray *et al.*, 2020). Alzheimer's disease and other neurological diseases are among the diseases that may benefit from further investigation into the link between air pollution and increased mortality (Peters *et al.*, 2019). The worldwide evaluation found that air pollution was among the top five risk factors, out of a total of 87, for the burden of disease it causes. Other major global health concerns include an unhealthy diet and tobacco use (Murray *et al.*, 2020).

Additionally, air pollution has health-related economic effects. These effects originate via two primary channels. The first, human health costs, are those associated with disease incidence and death and are assessed using the willingness-to-pay method. The second factor is decreased labor productivity (World Health Organization, 2021).

It is estimated that being subjected to high levels of air pollution results in the premature death of millions of people, the loss of thousands of healthy years of life, and the waste of trillions of dollars each year. Although there is still some debate about the exact disease burden, it is abundantly obvious that the global burden of disease connected with air pollution exacts a significant toll not just on human health but also on the economy of the whole globe. At this point in time, it is generally accepted that the environmental component that provides the biggest threat to human health and well-being is pollution found in the air (World Health Organization, 2021).

2.5 Air Quality Case Statistics in Tanzania

According to WHO ambient air pollution, a press release of 2012 (World Health Organization, 2016), poor air quality is considered the world's biggest environmental health risk, accounting for approximately 87% of global deaths in low and middle-income countries, with over three million premature deaths attributed to poor air quality. A total of 211 000 which is 7%, of the three million premature deaths, occurred in Sub-Saharan Africa. According to 2016 WHO report, ambient air pollution caused 5765 deaths in Tanzania, with the primary causes being acute respiratory, ischemic heart disease, and stroke (World Health Organization, 2016).

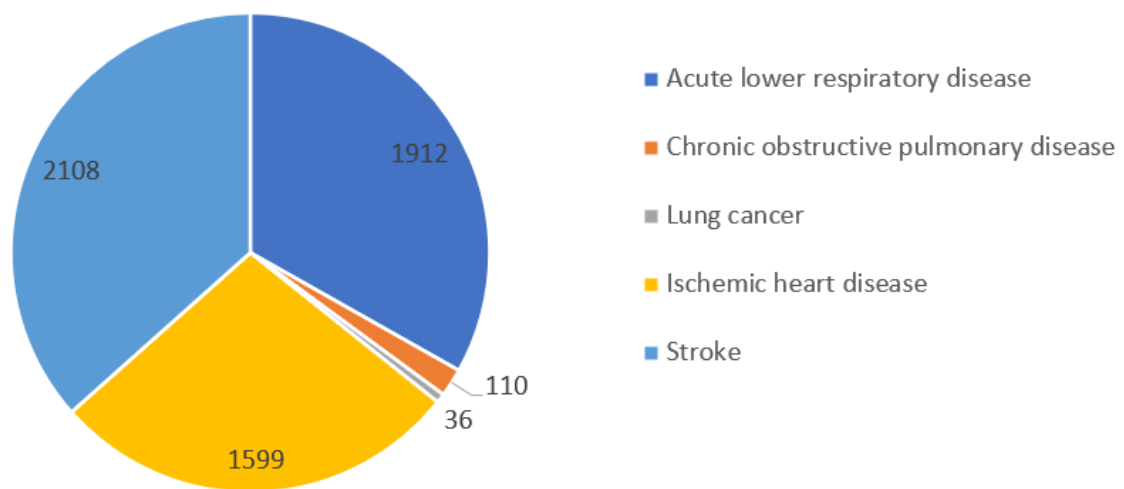

Figure 1: Deaths in Tanzania, attributed to ambient air quality 2012 (WHO, 2016)

2.6 Advantages of Integrating IoT for Air Quality Monitoring

The Internet of Things (IoT) is a cutting-edge technological advancement having a profound impact on industry expansion worldwide. Every sector is reaping the rewards of incorporating the sophisticated features of the Internet of Things and streamlining their entire processes, whether it is the fleet industry, environmental sector, agriculture sector, health sector, education sector, gas sector, or any other.

When IoT solutions integrated with environmental assets deliver enhanced solutions through real-time monitoring of the environment. This, as one of the primary advantages of integrating IoT with the environment, ensures a more effective strategy for monitoring and improving environmental conditions.

Internet of Things (IoT) air quality monitoring systems provide a data-driven approach to tracking air quality by utilizing sensor devices, gateway connectivity, and network technologies. These components work together to monitor air quality. To make cleaner settings that are free of air pollution and other airborne contaminants, the solution comprises all of the equipment and cutting-edge procedures that are required. It is simple to place in important areas, and once operational, it notifies the proper authorities to take immediate action in response to any potential threats. Various workplaces in the industrial sector have various requirements for the health and safety precautions that must be taken to protect their employees and residents.

2.7 Empirical Literature Review

Nirosha *et al.* (2017) developed a multifunctional Internet of Things (IoT) system to monitor parameters such as CO₂, alcohol, smoke, NH₃, and benzene, but it did not take into account PM_{2.5}, PM₁₀, or NO₂. In addition, the sensor node makes use of the wireless connection technology known as Wi-Fi, which operates over a short distance. Dhingra *et al.* (2019) based on Nucleo microcontroller to develop an Internet of Things (IoT) air quality monitoring solution. The emissions of polluting gases such as CO, CO₂, and NH₃ were the primary focus of attention. Particulate Matters were disregarded, and Wi-Fi, a technology for wireless communication across short distances, was utilized instead in the system.

The use of a long-range (LoRa) wireless technology for monitoring the air quality of laboratories on campus was presented by Truong *et al.* (2021). The system is capable of real-time monitoring of a large area's air quality. The system monitors PM_{2.5}/PM₁₀, CO₂, temperature, Humidity, CO₂, and NO₂. Collected data from sensor nodes are sent to the gateway using LoRa technology. The gateway board communicates with the cloud through a Raspberry Pi Zero equipped with Wi-Fi. However, the system lacks health hazards indication based on exposure to harmful gases.

The IoT wireless communication technologies for AQMS in public buses were presented by Saha *et al.* (2017). Sensor nodes are mounted on public buses to gather, analyze, and aggregate data on air quality. The data obtained by the sensor node is sent to sink nodes located at traffic intersections. These sink nodes collect, analyze and aggregate data from the sensor node and send acquired data to the collecting point which sends data to the cloud. Sink nodes are set not only to interact with sensor nodes but also to connect with one another in a mesh topology that

makes use of long-range radiofrequency, which allows the system to cover a large area of the city. However, the system is termed a real-time system but in a real sense, the system is not a real-time system because there will be a time delay waiting for the bus to reach the traffic junction for the sensor node to transfer data to the sink node.

Fuertes *et al.* (2015) presented a low-cost IoT device for monitoring CO₂, CO, and dust. The system used MQ7, MG-811, and GP2Y1010AU0F sensors to collect air quality data. Each sensor node was made up of an Arduino Uno microcontroller connected with an XBee module for data communication between the sensor node and coordinator. However, the system ignored other air pollutants such as PM_{2.5}/PM₁₀, temperature, and humidity. Ignoring all these parameters makes the air quality monitoring system incomplete. Firdhous *et al.* (2017) proposed an IoT system to monitor Ozone concentration near a high-volume photocopy machine. The system used an O₃ semiconductor sensor to collect data about ozone concentration levels and send the data to a gateway node through Bluetooth, which connects to the processing node using Wi-Fi. The system is limited to collecting only one parameter which in a real sense doesn't add much value to the air quality monitoring.

An android-based application has emerged with the advancement of wireless sensing (Manikannan *et al.*, 2019). The system is designed to monitor SO₂, CO₂, CO, and NO₂ gases. An Arduino Uno microcontroller connected with gas sensors and the ESP8266 Wi-Fi module was used to send the collected data to the cloud. Users can easily retrieve real-time data of the specific area through the android application developed. The system ignored important air pollutants such as PM_{2.5}/PM₁₀, temperature, and humidity.

The work presented by Hareva and Marsyaf (2019) used the WeMos-D1-R2 microcontroller board integrated with an MQ135 gas sensor for monitoring the quality of the air in the outside environment of the campus. The board has an ESP8266 wireless communication technology that was used to send the collected data to the MySQL database after every 5 minutes. A web-based tool for graphical data visualization and statistical analysis has been developed, which displays the lowest, maximum, and average air quality values, among other things.

Wu *et al.* (2020) designed an Internet of Things (IoT) device that is mounted to a bike to monitor air quality. The device used rechargeable batteries; these batteries are capable of being charged by the bike's power system. Humidity, temperature, CO₂, PM₁₀, and PM_{2.5} were monitored by this device. The data acquired by the device is sent to an App on the biker's

mobile phone over Bluetooth communication technology. The system doesn't give any health warning when air quality readings are above the threshold.

There are other ideas for indoor monitoring, such as Jo *et al.* (2020) developed an indoor air quality monitoring system. The system is equipped with a microcontroller, a 4G LTE modem, and gas sensors to collect data on air quality and transmit it to the cloud for real-time monitoring. The collected data were sent by using a 4G LTE mobile network. However, the study does not calculate the Air Quality Index (AQI), and does not specifically indicate diseases associated with air pollutants. The study focus on the development of an IoT-Based indoor air quality monitoring of carbon dioxide (CO₂), and volatile organic compound (VoCs) rather than the direct analysis of health effects.

AbdulWahhab (2019) presented a web-based system for indoor air quality. The system utilizes DHT11, and K-30 sensors to collect temperature, humidity, and CO₂ data. An Arduino Uno microcontroller extracts sensor data and sends it to the cloud using the ESP8266 wireless communication technology. The system is also able to predict the CO₂ condition of the next day using the Compact Prediction Tree (CPT+). The limitation of this study is the lack of enough parameters to monitor air quality. Also, an Arduino Uno microcontroller is less powerful in terms of memory and speed. The Wi-Fi module ESP8266 used to consume a lot of power than other wireless technologies such as Low Energy Bluetooth and ZigBee.

A fuzzy logical control IoT-based for indoor air-quality monitoring presented by Rane *et al.* (2018). The system was developed using Raspberry Pi 3, an Arduino microcontroller, and gas sensors to detect PM10, and CO₂ gases. The system is connected to a fan that will automatically turn on/Off based on the concentration level of the PM10 and CO₂ threshold. Message Queuing Telemetry Transport (MQTT) protocol was used to send to an Amazon Web Services (AWS) IoT cloud server for air quality monitoring in real-time.

2.8 Literature Review Observations

The use of various air quality monitoring sensors, wireless communication technologies, and microcontrollers has been discussed in the literature. However, none of the examined research took into account the multicriteria approach that has been implemented in my system. My suggested approach employs five different gas sensors (MQ135, MQ7, MQ136, PMS7003, MiCS4514, and DHT22). These gas sensors are used to detect toxic air pollutants such as CO₂, CO, NO₂, SO₂, PM2.5, PM10, temperature, and humidity. All these sensors are equipped in a

single sensor node to collect Air pollutants data. This system makes use of the most contemporary wireless technology known as LoRa (Long-Range) for data communication between sensor nodes and the gateway. The gateway uses Wi-Fi technology to send collected data to the cloud.

The use of LoRa technology in mines regions is the best approach as it overcame the limitations of short-range communication technologies such as ZigBee, Bluetooth, and Wi-Fi due to the nature of the environments. LoRa can span a distance of up to 10km in a line of sight and up to 2 km in the presence of obstacles. Wi-Fi can cover a distance of 100-300 m, ZigBee 50-300 m, and Bluetooth can cover up to 2-30 m only.

Long Range (LoRa) devices are power-efficient and can operate on battery power for extended periods. The technology uses a low-power wide-area (LPWA) approach, enabling long battery life, which is crucial for applications where frequent battery replacements are not feasible.

Long Range (LoRa) is optimized for transmitting small packets of data at low data rates. This makes it ideal for this system that require periodic transmission of sensor data. Also, LoRa operates in the sub-GHz frequency band, which offers better penetration through obstacles like walls and buildings compared to higher frequency bands used by Wi-Fi and Bluetooth. This results in improved signal strength and reliability.

Additionally, it was noted that most of the studies done do not analyze collected air pollution data to predict diseases that can result from people getting exposed to such an environment. Furthermore, many existing studies focus on outdoor and indoor air quality monitoring for smart cities and industries as opposed to mines regions. As this system is implemented in the region of the mine and is capable of giving health warning alerts about diseases that can affect people when they get exposed to such environments.

CHAPTER THREE

MATERIALS AND METHODS

3.1 Study Area and Scope of the Project

The project was carried out in the united republic of Tanzania, in the Shinyanga Region of the Kahama district specifically at the Bulyanhulu gold mining area, which is located in the Western part of Tanzania also known as Lake Zone because it is located approximately 55 km South of Lake Victoria. This study focuses on collecting air quality data in the areas surrounding mines. The project monitors air quality by integrating different environmental sensors with other hardware and web platform. The study examines eight parameters which are CO₂, CO, SO₂, NO₂, PM_{2.5}, PM₁₀, Temperature, and Humidity.

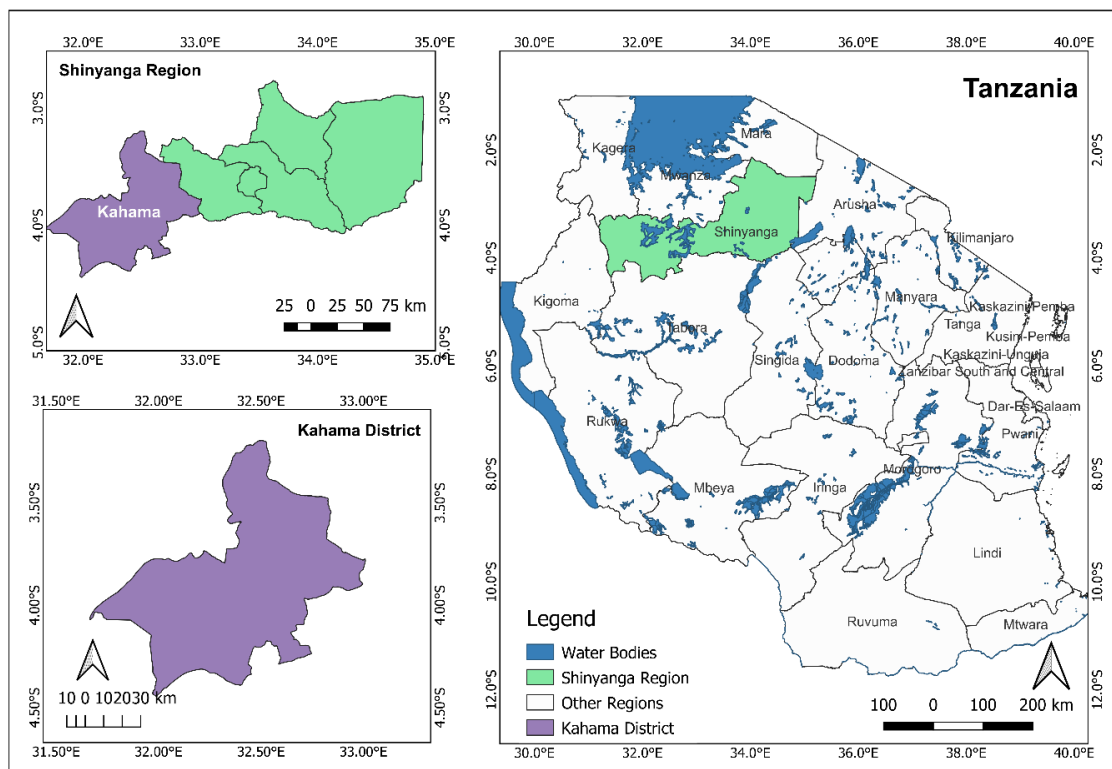

Figure 2: The study area map

3.2 Sampling Technique

In this study, non-probability convenience and Snowball sampling techniques were used to reach key personnel. Participants were chosen for the study based on their availability and willingness to participate. Convenience sampling makes the sampling process quicker and

more convenient compared to other sampling techniques. It is often less-time consuming and less expensive to implement since participants selected from their immediate surroundings.

The snowball sampling technique was selected as it is valuable when studying hard-to-reach or hidden populations like finding specific participants at mining places where works are on shift bases, and that are challenging to identify or locate. It relies on initial participants to refer and recruit others from within their social networks, allowing access to populations that may be difficult to reach through traditional sampling methods.

The snowball sampling technique was effective as the study based on the sensitive topic that may be reluctant to participate due to privacy concerns or stigma. The process allows for more discreet approach in some cases, and this increased the likelihood of many participants to participate in the study.

3.3 Data Collection Methods

In this study, both primary and secondary data were gathered using qualitative and quantitative approaches. Secondary data were gathered from different sources including books, journals, research papers, articles, and websites. Primary data were gathered using questionnaires. The key personnel involved during data collection includes miners, residents living near mines areas, safety officers, policymakers, and environmental officers.

3.3.1 Questionnaires

Both qualitative and quantitative questionnaires have been utilized in this study to gather data related to project objective number one. The questionnaires prepared were scheduled for miners and residents living in the villages near the Bulyanhulu gold mine, namely Kakola, Bushing'we, Namba 9, Busulwangili, Lwabakanga, and Busindi, both located at Bulyanhulu Ward.

The questionnaire was designed for comprehensive data gathering to encompass a wide range of questions, allowing collection of wide range of data as well as various types of requirements.

The questions prepared were grouped into three sections: The first section is about the personal information or demographic survey – this section was prepared to collect information such as age, gender, marital status, education level, and residence period. The second section is about mining activities and their impacts on the environment. The third section is about mining

activities and their health impacts. Closed questions were almost 85% of all questions in the questionnaire.

3.4 Data Analysis

Jupyter Notebook, a data analysis tool powered by the Anaconda package management, was used in conjunction with the Python programming language to analyze the data that was collected. Python is a fast and flexible programming language that is open-source and free to use. It may be used to quickly analyze data. Data from the excel file was loaded into Jupyter Notebook for analysis. The Pandas and Matplotlib libraries were utilized for data processing and graph plotting, respectively. Figure 3, depicts the data being put into Jupyter Notebook in preparation for analysis.

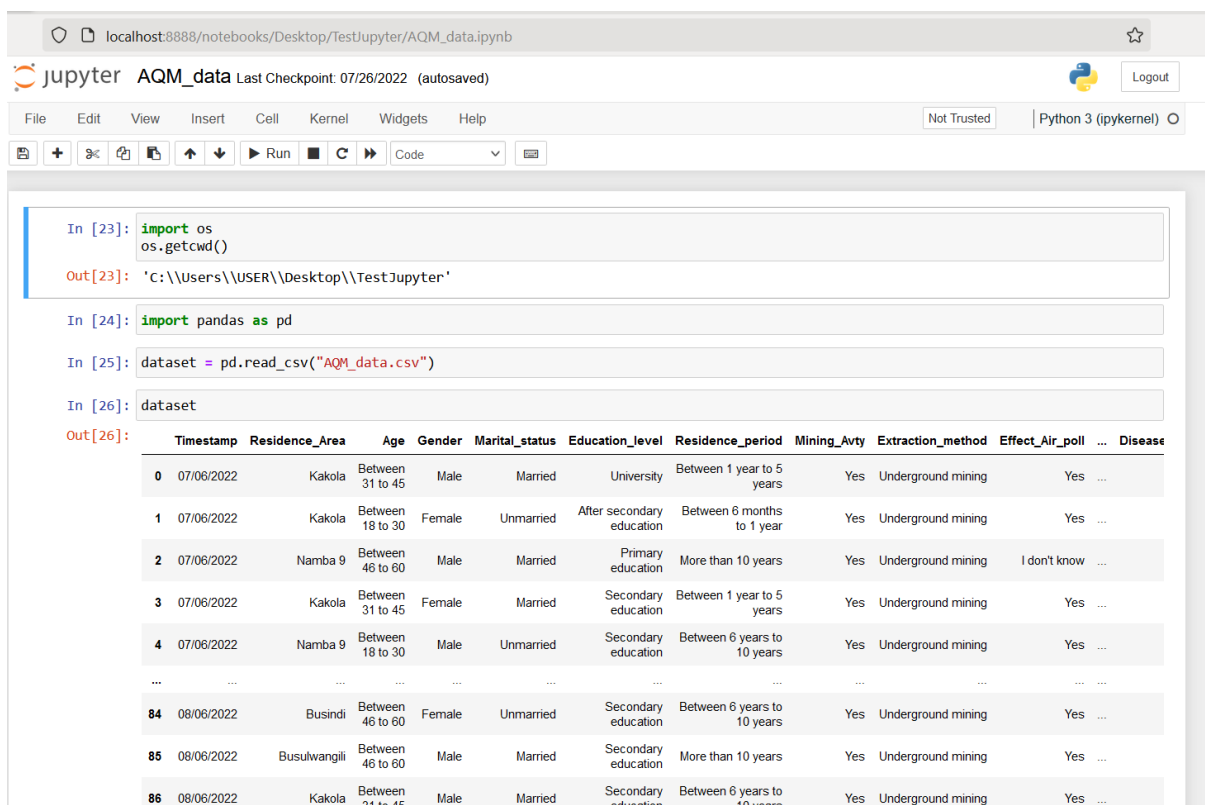

Figure 3: Excel CSV data file loaded into Jupyter Notebook for analysis

3.5 System Development Methodology

Extreme Programming (XP) Agile methodology was adopted throughout this study, from the collection of requirements to the system development and testing. It was implemented to expedite the system's delivery within the specified time frame, by offering a high-quality system at lower development costs than other traditional models, it focuses on a remarkably

quick development cycle, emphasizes iterative development and testing throughout the software development lifecycle (Al-Zewairi *et al.*, 2017).

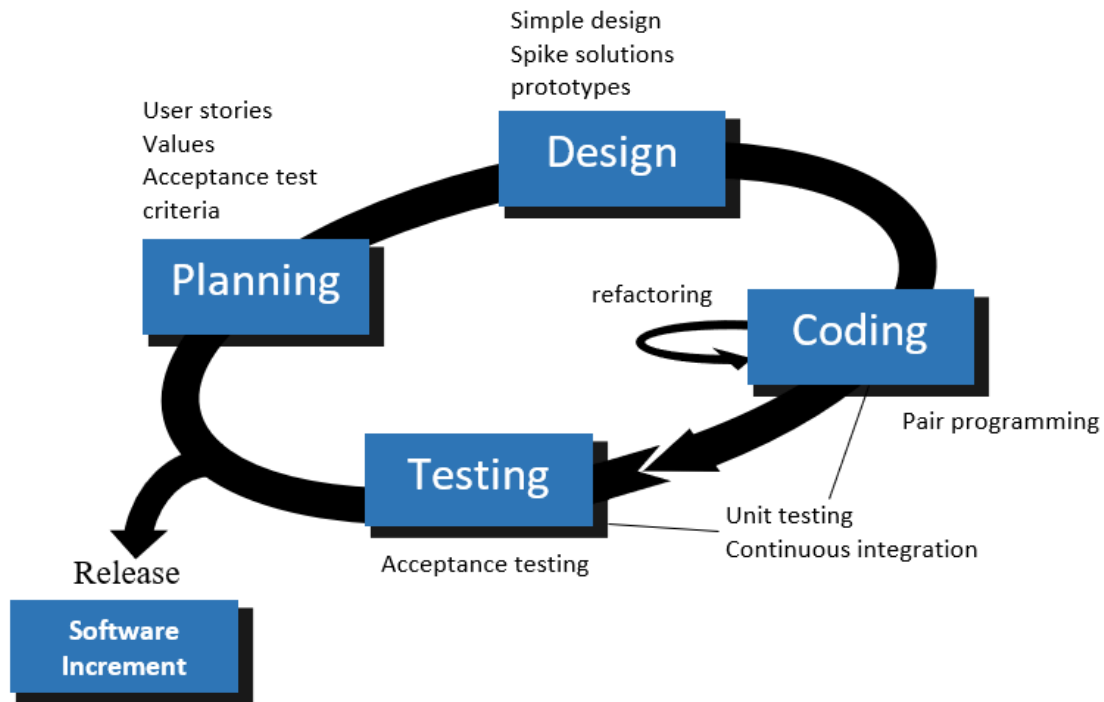

Figure 4: Agile extreme programming software development model

3.6 System Modeling

The gathered requirements were analyzed using graphical languages by the rules and artifacts of the Unified Modeling Language (UML). StarUML was used to simulate the system. StarUML was used to map the requirements collected into a use case diagram, a data flow diagram (DFD), a flow chart, an activity diagram, and a state diagram.

3.6.1 Flow Chart

The flow chart diagram illustrates the overall process that the proposed system will go through. The sensor nodes and the gateway node are the components that make up the system. Sensor nodes are outfitted with a variety of sensors that detect the characteristics of air pollutants. These sensors then transmit the gathered data to an Atmega328 microcontroller, which utilizes the LoRa shield to transmit the data to the gateway. The data flow diagram for the sensor node can be seen in Fig. 5, and the data flow diagram for the gateway node can be seen in Fig. 6.

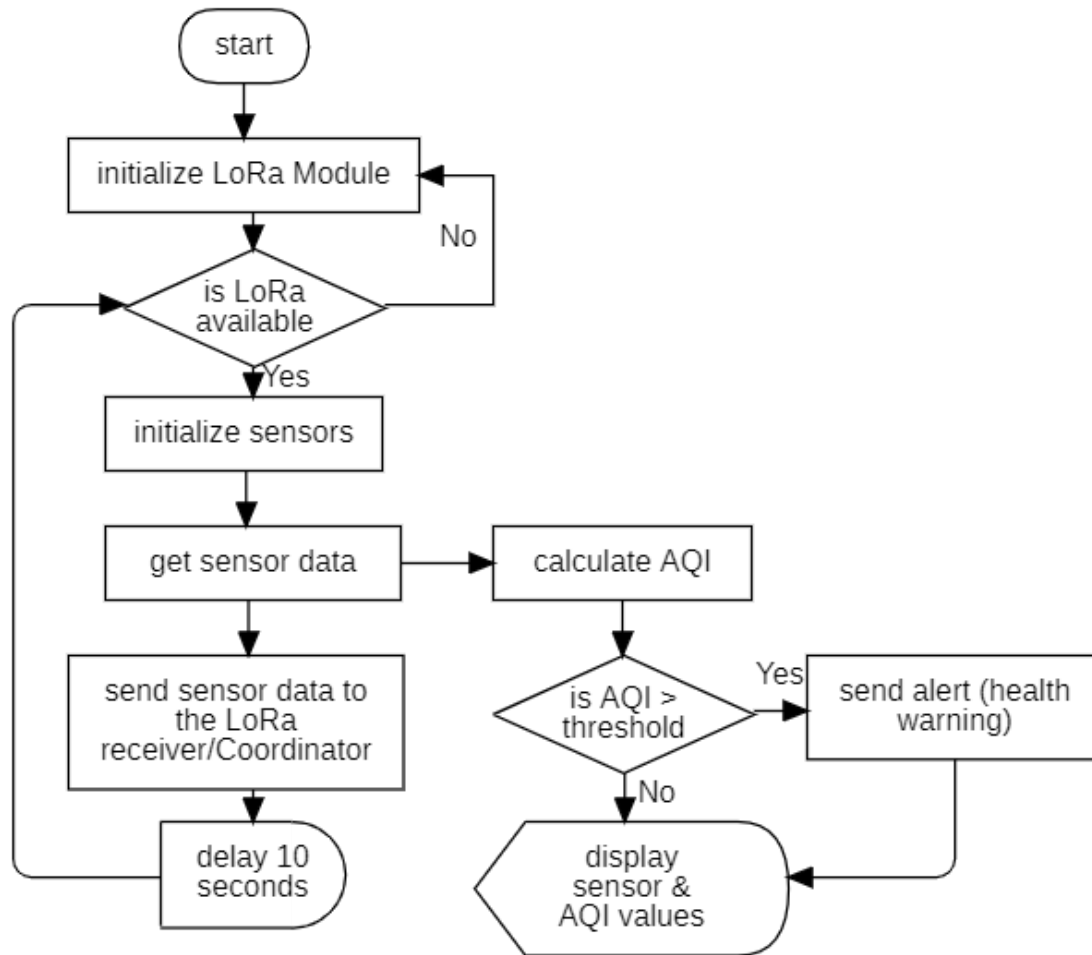

Figure 5: Flow chart diagram for sensor node

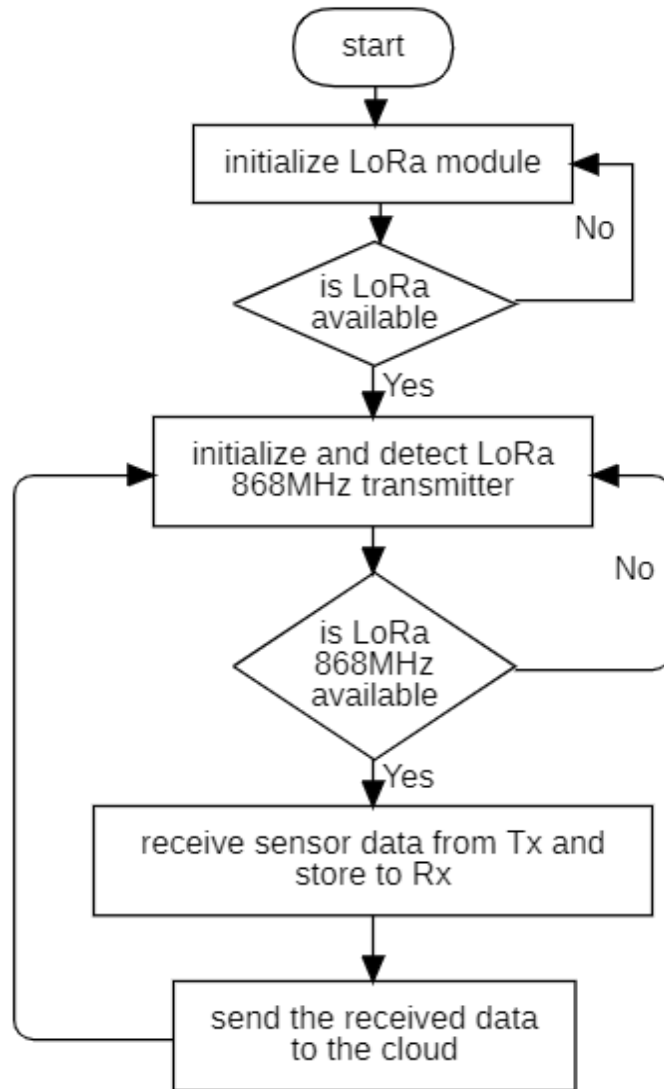

Figure 6: Flow chart diagram for the gateway node

3.6.2 Use Case Diagram

Users and the system interactions are shown using the use case diagram. This project identifies three primary actors namely system admin, safety/environmental officers, and normal users (miners/staff/residents). The core function of the system admin is to register and manage system users, monitor air quality, and generate air quality reports. The core function of safety/environmental officers is to monitor real-time air quality data, view, and print reports, as well as receiving health hazard notifications when the AQI is exceeding the threshold. The core function of normal users is to view real-time air quality data and the AQI as well as receive health hazards notifications.

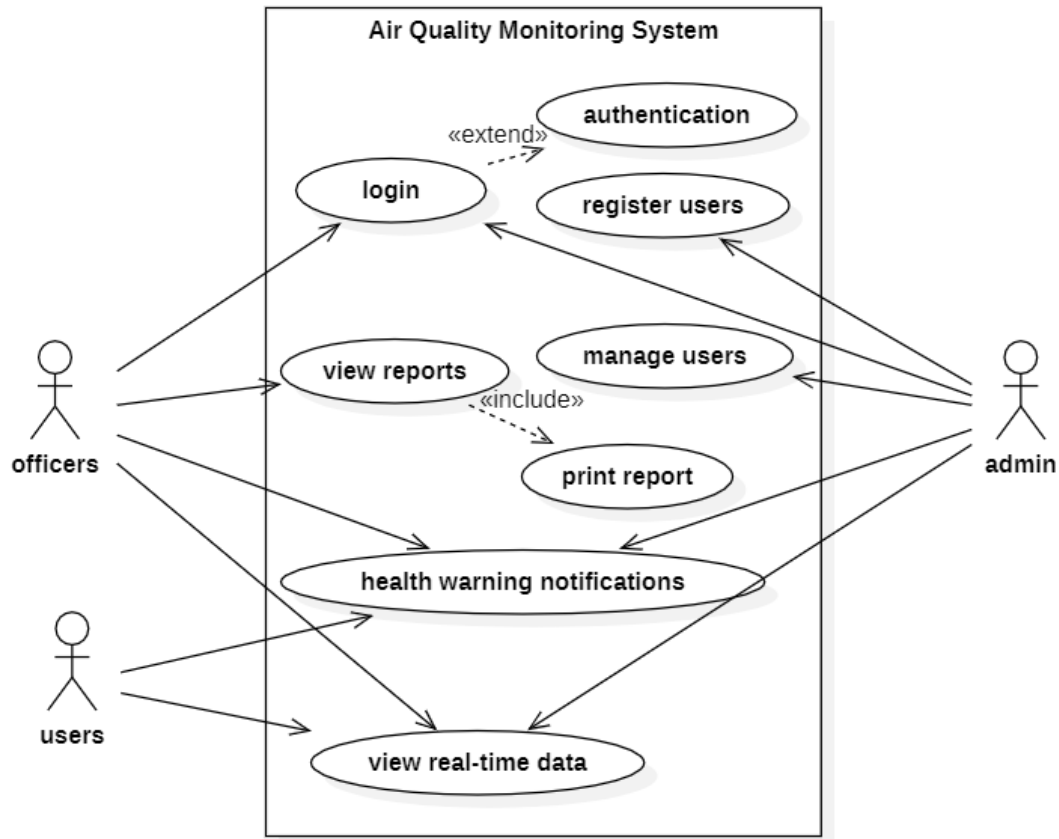

Figure 7: System use case diagram

3.6.3 Data Flow Diagram

The Data Flow Diagram (DFD), is used to graphically represent the flow of data in the system. Level 0 of the Data Flow Diagram (Fig. 8), describe the basic overview of the entire system in a context diagram displaying a single process and its interaction with external entities. Level 1 of the Data Flow Diagram (Fig. 9). describes the logical data flow processes that are involved in the air quality monitoring and health hazards indicator system in performing certain functionalities involved in a system and the processes involved to transfer data from the input to the output, storage, and reports generations.

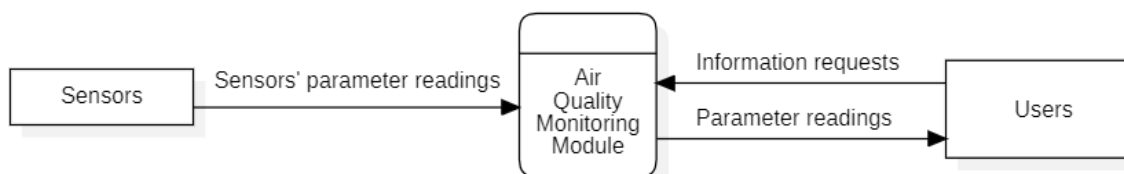

Figure 8: Data flow diagram level 0

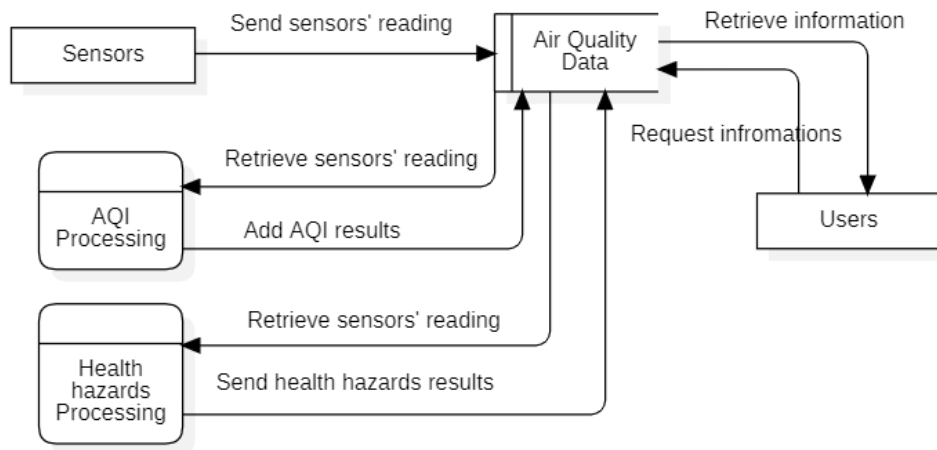

Figure 9: Data flow diagram level 1

3.7 Sensor Node Design

The sensor node or LoRa node consists of the Atmega328 microcontroller, sensors, and LoRa shield. Sensors are utilized in this system for tracking and collecting air pollutants parameters such as SO₂, CO₂, CO, NO₂, PM2.5, PM10, temperature, and related humidity. Sensors are attached to the Atmega328 microcontroller which is integrated with a LoRa shield. The sensed data from sensors are transmitted to the cloud through the LoRa shield via the LoRa gateway. The PMS7003 sensor monitors PM2.5 and PM10, while MQ135 measures CO₂, MQ136 measures SO₂, MiCS 4514 detects NO₂, DHT22 reads the temperature and humidity, and MQ7 measures CO. In addition, Solar panels with a rechargeable battery, lithium-ion 12v battery is used to supply power to the sensor node. Figure 10 shows the sensor node framework overview design.

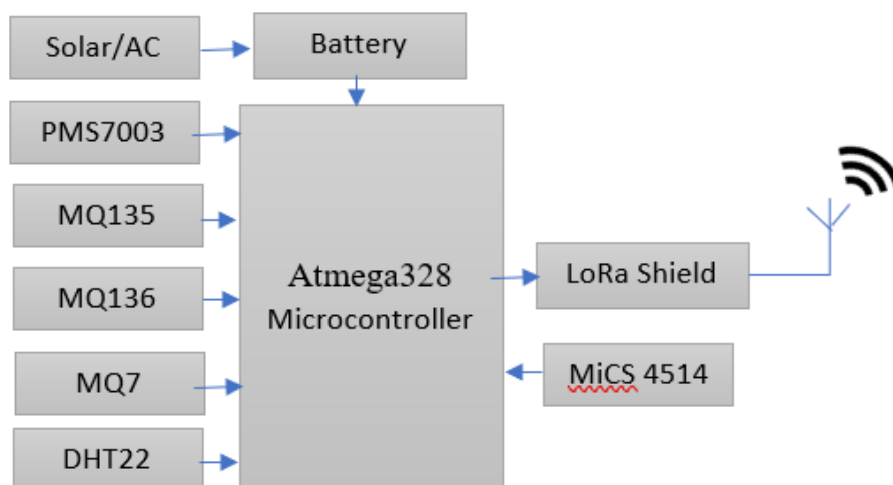

Figure 10: Sensor node framework design

The overall layout of the system's circuits is shown in a schematic circuit diagram in Fig. 11. It is simple to use a schematic circuit diagram to follow the path of a circuit and determine the components that make up a system. A schematic circuit diagram depicts the primary characteristics or connections of the system's components and connectors. A schematic diagram is a type of diagram that uses visual symbols to depict the components of a system rather than photographs or other types of actual images. This particular system's circuit diagram places a greater emphasis on understanding and disseminating information on the system.

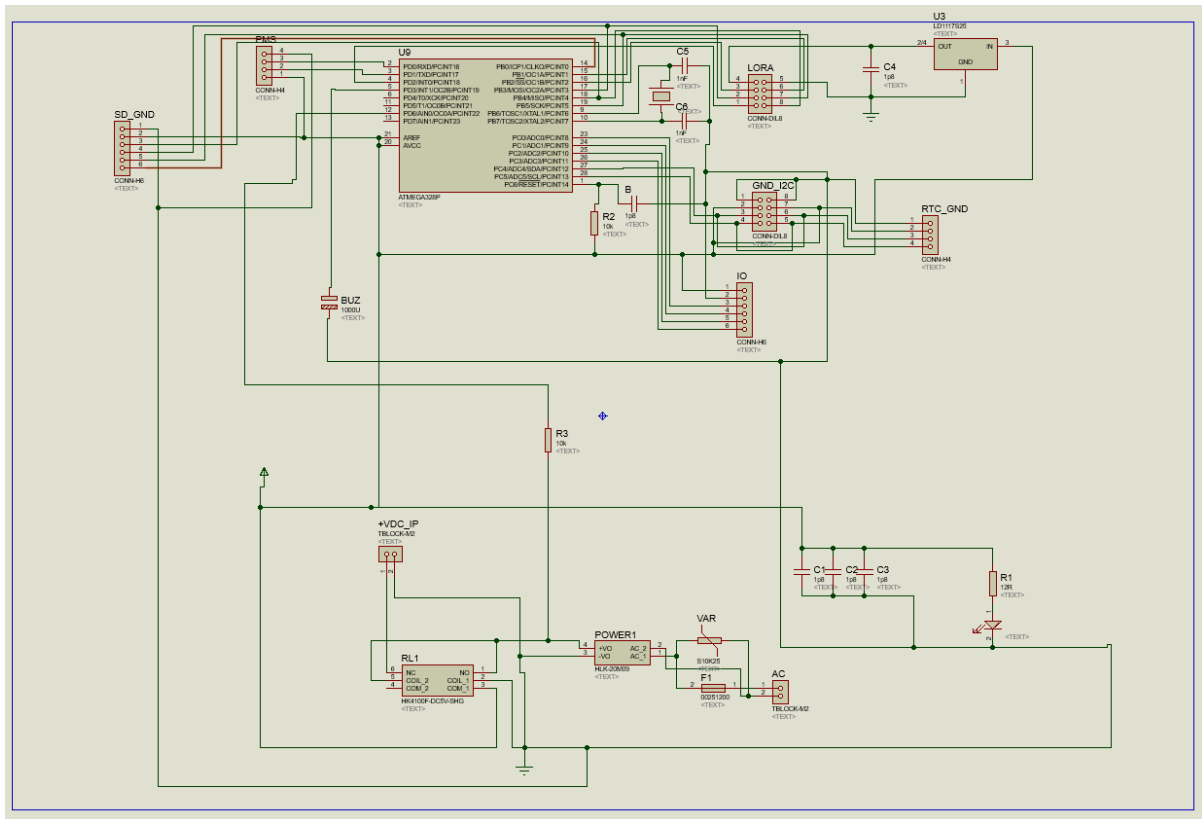

Figure 11: Sensor node Schematic circuit design

Figure 12 shows the 3-dimension (3D) visualizer circuit design of the sensor node. The 3D visualizer circuit design shows the illustration of a 3-dimensional circuit design before being printed. The 3D design help in reviewing the design and provides design for test feedback by enabling a graphical view of the circuit design. The 3-dimension (3D) visualizer design is used to easily highlight faults in both layout and schematic view.

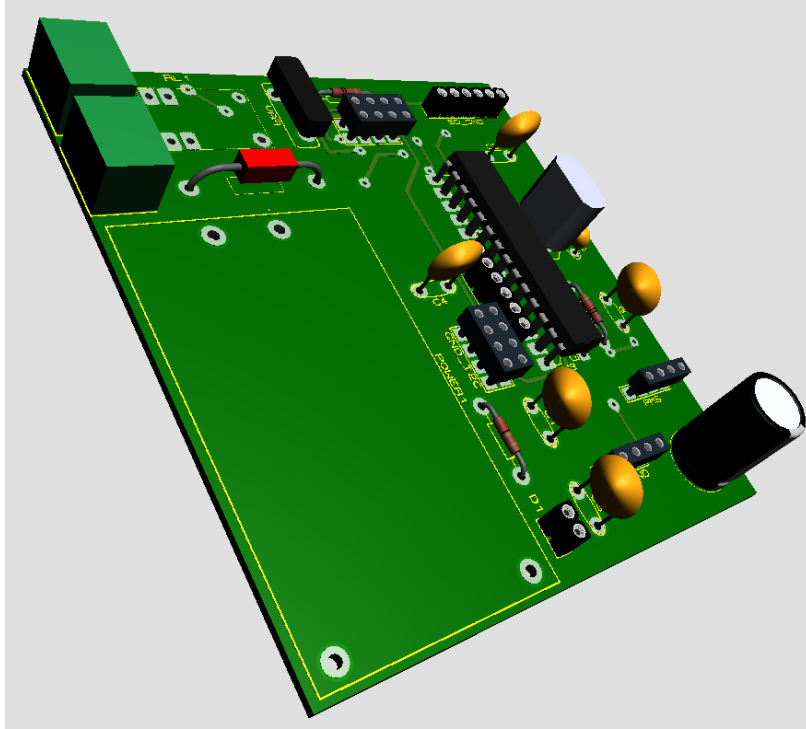

Figure 12: The 3D circuit design of the sensor node

Figure 13 shows the printed circuit board (PCB) layout of the system. The printed circuit board (PCB) layout board indicates several processes required in designing and connecting electronic components. It involves mounting holes cutouts, labeling, specifying component locations, making traces, and wire routing.

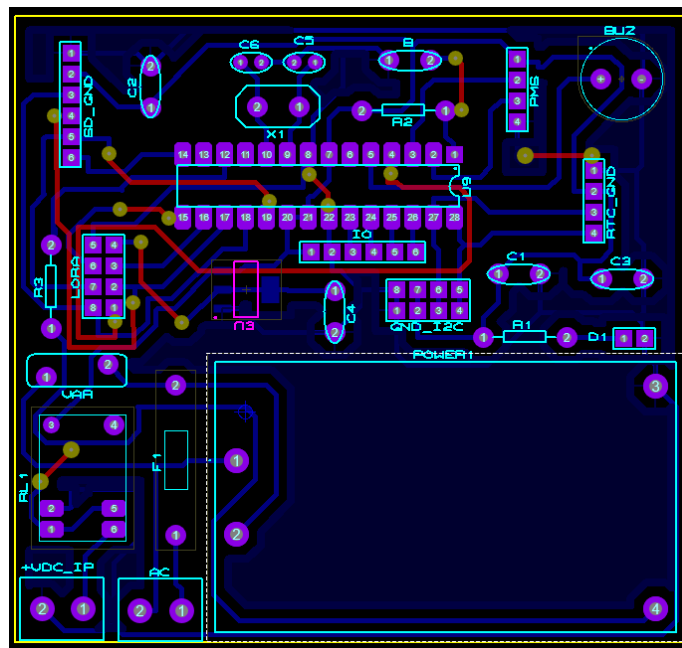

Figure 13: Printed Circuit Board layout

3.8 System Architecture Design

The architecture of this system is mainly divided into two parts: a sensor node or LoRa node, and a gateway node or Long Raange Wide Area Network (LoRaWAN) gateway. The overall system architecture consists of mainly four parts: (a) several sensors used to sense and measure different air pollutants parameters, (b) a LoRa network that consists of a LoRa shield in the sensor node and a gateway node, all of them are connected to the Atmega328 microcontroller as the main controller, (c) ThingSpeak cloud server for data storage, visualization, and integration, (d) a user application system that consists of a web-based application that can be accessed via a computer or smartphones web-browsers.

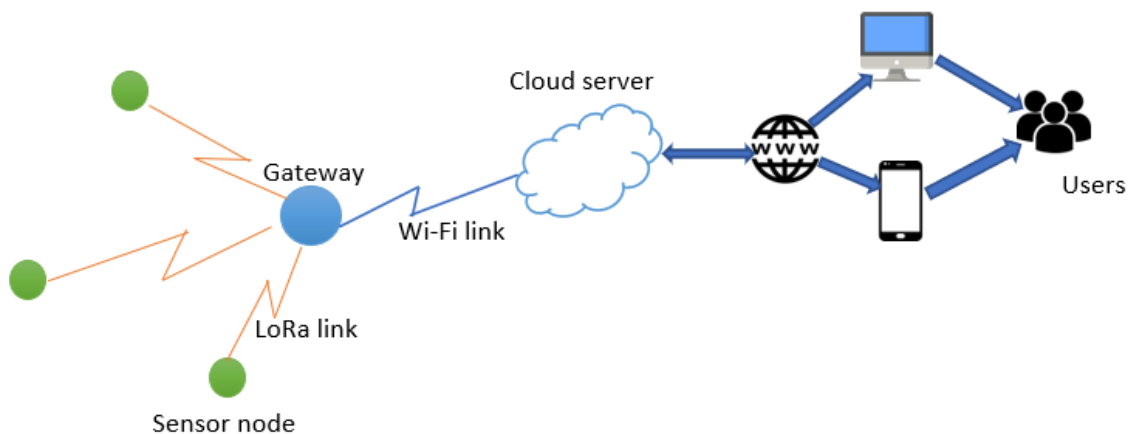

Figure 14: System architecture design framework

This system makes use of a wide variety of sensors in order to detect the many characteristics of air contaminants. A variety of sensors, including PMS7003, DHT22, MQ135, MQ136, MQ7, and MiCS4514, have been chosen to be utilized in the process of detecting different air parameters, including SO₂, CO₂, CO, NO₂, PM2.5, and PM10, as well as temperature and humidity.

The data that has been detected is transmitted to the LoRaWAN gateway by the sensor node via the LoRa shield. The Atmega328 microcontroller is utilized in the process of collecting data from sensors and coordinating its utilization. Payload streams consisting of the transferred data are sent to the gateway. The streams of payloads are posted to the ThingSpeak server as soon as the gateway gets data from the LoRa node.

After that, the data are uploaded to the web-based application, which allows users to easily observe and visualize the real-time air quality metrics as well as the AQI value of the location through the internet.

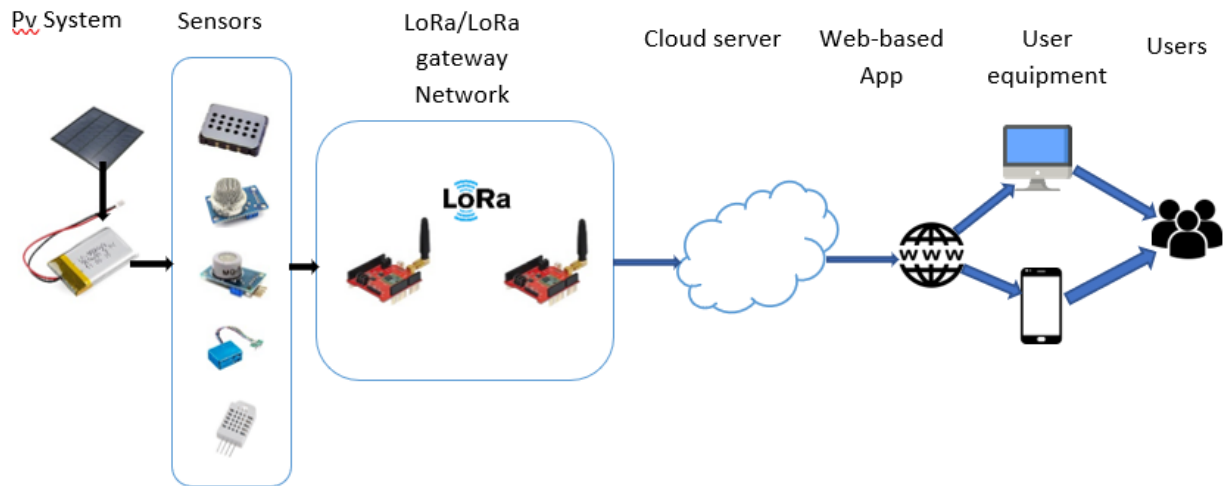

Figure 15: System architecture layout design

3.9 Hardware and Software Components

In this project, various hardware and software tools were employed for the development of a real-time air quality monitoring and health hazards indicator system. The hardware and software selections based on quality, security, availability, reliability, and user-friendliness.

3.9.1 Software Components

The software tools used for the development of this project were divided into two parts: embedded systems software development tools, and web-based software tools.

(i) Embedded systems software development tools

The design and development of the embedded system part employ the use of the Proteus circuit designing tool. Proteus was used for PCB circuit designing and simulation, the choice was due to the compatibility of the tool and the availability of many development features available in the tool. Arduino Integrated Development Environment (IDE) which uses C++ language was used for programming the microcontroller. Another tool used for the initial design of the embedded part was fritzing software.

(ii) Web-based software development tools

Different tools were employed for the development of the database, front-end, back-end, and of web-based air quality monitoring system.

(a) Hypertext Markup Language

The Hypertext Markup Language, or HTML, is a standard markup language that is used to define the structure and presentation of a web page. The HTML also instructs the browser on how to arrange and display the contents of the page. Throughout the process of developing this project, HTML 5 was utilized. The most recent version of Hypertext Markup Language is referred to as HTML 5.

(b) Cascading Style Sheet

The Cascading Style Sheet (CSS) is a tool that is used to style components that are specified in a markup language such as HTML. It separates the website's content from the visual representation of the site. The HTML is a website's essential structural backbone, while CSS is responsible for the page's overall look, therefore the two are closely related. In order to style the web pages, CSS 3 was utilized.

(c) JavaScript

JavaScript is a scripting language that is dynamic and allows the implementation of complex features on a web page. Is a client-side and lightweight scripting language that interacts directly with users and makes dynamic pages. It does more than just displaying static content. JavaScript was employed in the development of the web-based part of this project to display timely content updates, gauges, and animated graphs.

(d) Bootstrap

Bootstrap is a free and open-source development framework for the creation of websites. Bootstrap combines the full features of HTML, CSS, and JavaScript and from a framework used to create a front-end responsive web page. Bootstrap was employed in this project to create looking and responsive web pages for an air quality monitoring system. Bootstrap 5 was selected as it is the new version of bootstrap and the most powerful and full feature-packed toolkit of the Bootstrap framework.

(e) Hypertext Preprocessor

Hypertext Preprocessor (PHP) is an open-source server-side scripting language that is embedded in HTML for creating dynamic web pages. The PHP can only be interpreted on a server side that has PHP and Apache installed. The PHP is used to perform different functions in the system such as database elements handling, forms handling, files handling, users access control, session control, and data encryptions and decryptions.

(f) MySQL

MySQL is a relational database management system (RDBMS) that is built on a structured query language (SQL). MySQL database is used to develop and administer databases for air quality monitoring system because it is highly quick, reliable, scalable, and easy to use. MySQL database is also open-source software, which means it is free to use. MySQL 8, the latest version of the database, was utilized throughout the creation of this project. MySQL 8 allows for numerous authentication methods and enables the creation and administration of resources, groups, and threads operating within the server. This allows threads to execute based on the resources that are accessible to the group.

3.9.2 Hardware Components

The hardware components consist of various sensors for detecting CO₂, CO, SO₂, NO₂, PM2.5, PM10, Temperature, and Humidity. The microcontroller used for both sensor nodes and gateway are Atmega328. Other hardware components include a busser, LED, and LCD.

The selection of these hardware components was established during requirements gathering using the Design Thinking approach. This approach enables individuals to focus on people's needs while designing a solution (Kumar *et al.*, 2020). The hardware components used in this project are described below.

(i) Atmega328 microcontroller

The ATmega328 is a microcontroller that uses the Advanced Virtual RISC (AVR) instruction set. It is capable of processing data in 8 bits. ATmega-328 possesses 32 KB of internal flash memory, 1 KB of Electrically Erasable Programmable Read-Only Memory (EEPROM), 2 KB of Static Random Access Memory (SRAM), 8 Pins for ADC operations, 3 built-in Timers, two

of which are 8 Bit timers and the third of which is a 16-Bit Timer, a programming lock for the purpose of ensuring security, a real timer counter with a separate oscillator (Nasir, 2017).

(ii) LoRa Ra-02 SX1278 Module 433MHz

The SMTECH SX1278 wireless transceiver serves as the foundation for the SX1278 LoRa module, which functions as a wireless transmission module. The cutting-edge LoRa spread spectrum technology that it employs enables it to have a communication range of up to 10 km. It possesses superior anti-jamming characteristics, in addition to a function that allows for the consumption of air during the wake-up process.

This project relied on the SX1278 RF LoRa module for long-distance spread spectrum communication since it not only has the capacity to tolerate stress but also reduces the amount of current that it needs to operate. In addition to its extensive transmission range, great durability, and high sensitivity, the SX1278 LoRa module boasts a power output of +20 dBm and a sensitivity of -148 dBm.

In addition, compared to standard modulation technology, LoRa modulation technology has evident benefits in anti-blocking and selection, hence eliminating the problem that present design methods cannot account for distance, interference, and power consumption (Daud *et al.*, 2018).

(iii) MQ135 Sensor

The MQ135 gas sensor is a well-liked gas sensor from the MQ family of sensors, which are frequently utilized in air quality control equipment. It operates at 5V and draws around 150 mA of current.

The MQ135 gas sensor has the capability of identifying potentially hazardous gases and smoke, such as sulfur (S), benzene (C₆H₆), ammonia (NH₃), and carbon monoxide (CO). This sensor includes both digital and analog output pins in its design. When the level of these gases in the air reaches a certain threshold that we have set, the digital pin will begin to rise. The value of this threshold can be adjusted using the inbuilt potentiometer if necessary. The analog output pin supplies an analog voltage that may be utilized in the process of estimating the ambient concentration of a variety of gases.

The sensor's digital output pin is utilized to identify harmful atmosphere gases. The digital pin sensitivity can be adjusted by using the 10-k potentiometer. If the gas is detected, the indicator LED DO will light on and the digital pin's logic state will change from high to low (0V). The actual gas value is compared with the potentiometer-set value using the LM393 Op-Amp Comparator IC. If the actual gas level exceeds the specified value, the digital output pin goes low (Components101, 2022).

(iv) MQ136

The MQ136 gas sensor is responsible for measuring the amount of hydrogen sulfide gas and sulfur dioxide (SO₂) gas in the air. This sensor is made using a tiny AL₂O₃ ceramic tube, a sensitive layer of tin dioxide (SnO₂), a measuring electrode, and a heater, all of which are fastened into a crust consisting of a stainless-steel net and plastic. The heater creates a certain environment in which sensitive components may function. The MQ136 sensor contains six pins; however, only four of them are utilized to retrieve signals; the remaining two pins are employed to supply heating current (Nawazi, 2021).

(v) MQ7 Sensor

The MQ7 gas sensor has high sensitivity and fast response time. The primary function of MQ7 is to detect Carbon Monoxide (CO). This sensor has a ceramic sensing element coated with Tin dioxide (SnO₂) and encased in stainless steel mesh. The resistance of the detecting element changes as it comes into contact with CO gas. The concentration of gases may then be determined by comparing the change to the original value. The MQ7 sensor contains a small heating element that is necessary for preheating the sensor to the operating window. It can detect CO gas levels in the air ranging from 20 PPM to 2000 PPM (Hanwei, 2022).

(vi) PMS7003

The PMS7003 dust sensor monitors the purity of the air by measuring PM_{1.0}, PM_{2.5}, and PM₁₀. Equipped with a sensor that detects particles with diameters greater than 0.3 μm, such as small particles of dust and cigarette smoke. The chip is powered by a 5-volt supply, whereas the interface operates on a 3.3-volt supply and communicates via the UART interface (Espruino, 2017).

(vii) MiCS 4514

This is a gas concentration sensor that is compatible with 3.3 and 5 volts. This sensor is capable of detecting a wide range of gas concentrations, including NO₂, CO, C₂H₅OH (alcohol), H₂, and NH₃, and its code incorporates a number of different formulae for converting gas concentrations, which makes testing and using sensors much simpler. With an I2C output and a broad voltage input ranging from 3.3 to 5.5 volts, it is compatible with a wide variety of microcontrollers, such as the Atmega328, as well as other popular controllers, and it is able to monitor levels of NO₂ ranging from 0.05 to 10 ppm (DFRobot, 2022).

(viii) DHT22

The DHT22 is an easy-to-use and inexpensive digital sensor that can monitor temperature as well as humidity. It accomplishes this by analyzing the air around it with a thermistor and a capacitive humidity sensor and then sending a digital signal out through the data pin (no analog input pins needed). Its precision in measuring temperature is ± 0.5 degrees Celsius, and its temperature measurement range is from -40°C to $+125^{\circ}\text{C}$. In addition to this, the DHT22 sensor has a wider range for measuring humidity, which extends from 0% to 100% and is accurate to within 2-5% (Ada, 2022).

(ix) Real Time Clock module DS3231

The DS3231 is an I2C real-time clock (RTC) that is both inexpensive and very accurate. It comes equipped with a temperature-compensated crystal oscillator (TCXO) that is built right in as well as a crystal. The DS3231 is the component that is in charge of controlling all timekeeping activities, and it has a straightforward I2C interface that consists of only two wires and can be easily connected to a microcontroller.

The chip is responsible for storing a variety of data, including seconds, minutes, hours, days, dates, months, and years. For months that have fewer than 31 days, the date at the end of the month is adjusted in a manner that also takes into account modifications for leap years (valid up to 2100). The time may be displayed in either 12- or 24-hour format, and it also shows the current time in both AM and PM format.

Along with programmable square-wave output, this device also features two time-of-day alarms that may be set to go off at specific times of the day. Serialization of addresses and data is accomplished through the use of a bidirectional I2C bus (Patel, 2022).

(x) Buzzer (Buzzer Piezoelectric Passive)

A piezoelectric Passive Buzzer is a Small PCB Mountable Passive Buzzer. It operates on 5v. It has been incorporated into the system in order to provide an Audio Alert for the systems. It generates an audible tone using a coil element and runs off of a supply voltage of 5 volts (Suryateja, 2018).

(xi) 12V Lithium-ion Rechargeable Battery

A rechargeable 12v lithium-ion battery with a capacity of 5000mah, with PVC or plastic casing, was used as the power storage battery and used to power the device. This battery is of high quality, meets all the device requirements and it's environmentally safe.

(xii) 5v Relay

A 5v relay is a sort of automated switch that is often utilized in an automatic control circuit to regulate a high-current signal with a low-current signal. This is accomplished by connecting the output of the relay to the input of the control circuit. The input voltage for the relay signal can be anything between 0 and 5v.

(xiii) 20x4 LCD screen

There are four rows of display in a 20x4 LCD module. Each row has the capacity to show twenty characters, and the entire display has the capacity to show eighty different characters. Parallel interfacing is utilized by this liquid crystal module, which utilizes HDD44780, which is a controller that displays monochrome text displays. This module uses the input supply of plus five volts, although it is also capable of functioning on the supply of plus three volts (Jones, 2019).

(xiv) AC-DC power module (HLK-20M05 220V to 5V4A20W)

The HLK-20M05 220 V to 5V4A20W AC-DC Power Supply Module is a plastic-enclosed, PCB-mounted, isolated switching step-down power supply module. It features a wattage output of 20 watts. It has a power rating of 20 watts and is able to provide 5 V DC from 100 V AC or

240 V AC input voltage. Because of this, it is an excellent choice for the job at hand, which requires a supply of 5 volts from the mains.

(xv) Solar Cell 12V 1.5W 150mAh

This solar cell has a high conversion efficiency and output power it has a maximum power rating of 1.5 W, a voltage of 12 V, a current of 0 to 100 mA, perfect craftsmanship, windproof and snow proof performance, simple to use, and easy to install. The Solar panel is light, stylish, sturdy, beautiful, environmentally friendly, and small in size. This Solar cell used in the project as source of power for the device.

(xvi) MicroSD Card Module for Arduino

The SD card module and the micro-SD card module both make it possible to interface with the memory card and either read or write the information stored on it. SPI is the protocol that the module interfaces with. In the context of this particular project, it is utilized primarily to store data locally as a backup data while other copies of data are transmitted to the cloud.

(xvii) Copper Clad Board Double Sided

Copper Clad Laminate Double-Sided PCB Circuit Board constructed out of FR4 glass fiber material and measuring 15 by 20 millimeters with a thickness of 1.5 millimeters. Conductive tracks, pads, and other features are etched from copper sheets that are bonded onto a non-conductive substrate. These features provide mechanical support for the electronic components as well as electrical connections between the components.

(xviii) 5A DC-DC XL4015 Adjustable Buck Module

An adjustable step-down (buck) converter which can be used to lower the voltage from input voltage of range 8 – 36 V DC to 1.25 – 35 V DC (adjustable with a potentiometer on the IN side) with a maximum output power of 75 W.

3.10 Air Quality Index

The Air Quality Index (AQI) is used to convey to the public whether the air is contaminated or clean. The AQI is computed by averaging the data from air quality monitors which may arise due to, mining activities, industrial activities, vehicle traffic, fires, and others.

Think of the Air Quality Index (AQI) as a measuring rod with a range from 0 to 500. The higher the value of the AQI, the more severe the air pollution and the greater the potential dangers to one's health. For example, if the AQI value is 50 or below, it indicates that the air quality is acceptable or good for human health, but an AQI value of greater than 300 indicates that the air quality is hazardous for human health.

An AQI of 100 indicates that the concentration of pollutants in the air is equivalent to the national short-term ambient air quality limit for public health protection. When the AQI is below 100, is considered safe. When the AQI rises beyond 100, the air quality becomes unhealthy, first for those with sensitivities or sensitive groups but then for everyone.

There are six groups within the AQI. There is a different degree of health risk associated with each group. There is a designated color for each classification/group as shown in Table 1. Color serves as a fast indicator of whether or not air quality has reached harmful levels in a certain area.

Table 1: Six Air Quality Index (AQI) categories

Index Values	Levels of Concerns	AQI Color
0 to 50	Good	Green
51 to 100	Moderate	Yellow
101 to 150	Unhealthy for Sensitive Groups	Orange
151 to 200	Unhealthy	Red
201 to 300	Very Unhealthy	Purple
301 and higher	Hazardous	Maroon

3.10.1 Pollutant-Specific Sensitive Groups

Air pollution contributes to a broad spectrum of adverse health effects. As indicated in Table 2., the majority of air pollutants, including carbon monoxide, nitrogen oxide, sulfur dioxide, particulate matter 2.5, and particulate matter 10, have direct impacts on sensitive groups.

Table 2: Pollutant-specific sensitive groups

Pollutants with AQI above 100	Sensitive Groups
PM2.5	The most vulnerable populations are those with heart or lung disease, the elderly, young children, and those from poor socioeconomic backgrounds.
PM10	Those with pre-existing conditions like heart or lung disease, the elderly, young children, and those from poorer socioeconomic backgrounds are at a higher risk.
CO	Those with heart problems are most in danger.
NO ₂	Asthmatics, young children, and the elderly are the most vulnerable populations.
SO ₂	Asthmatics, young children, and the elderly are the most vulnerable populations.

3.10.2 Pollutant-Specific Sub-indices for Air Quality Index Guidance

As shown in Table 3, the health-related AQI values coincide with pollutant-specific health and warning statements. These statements point out straightforward actions that individuals may take to reduce their exposure to air pollution. For instance, the AQI for particle pollution is regarded to be "unhealthy for sensitive groups" when it is between 101 and 150, often known as Code Orange. It is suggested that persons with heart or lung diseases, the elderly, children, and those who have diabetes to limit their participation in extended or intense exercise while the AQI level is within this range.

Table 3: Pollutant-Specific Sub-indices and Warning Statements for AQI Guidance

AQI Values	Who Needs to be Concerned?	What Should be done?
Good (0 to 50)	It's a great air quality	
Moderate (51 – 100)	People who may be unusually sensitive to particle pollution.	People in sensitive groups, those with asthma, and those with cardiovascular disease should limit their physical activity and keep an eye out for signs like coughing and shortness of breath.
Unhealthy for Sensitive Groups (101 – 150)	Sensitive groups include people with heart or lung disease, older adults, children, and teenagers.	Older people, with lower socioeconomic conditions, children, and those who suffer from heart or lung diseases should limit their exposure to prolonged or intense activity and keep a close eye out for signs such as coughing or shortness of breath.
Unhealthy (151 – 200)	Everyone	Everyone should limit their exposure to lengthy or intense physical activity, stay away from sources of pollution, and avoid any activities that take place outside.
Very Unhealthy (201 – 300)	Everyone	Avoid all physical activities outside. Avoid prolonged or heavy exertion.
Hazardous (301 – 500)	Everyone	Avoid all physical activities outdoors.

3.10.3 Calculating the AQI

When attempting to evaluate air quality, raw data might be challenging to understand. This is why there is a metric for measuring air quality. Through the use of a numerical value called an air quality index (AQI), through this, the level of pollution in the air may be more easily understood.

The AQI is the highest determining value for each pollutant. The computations must first identify and truncate the greatest concentration among all of the monitors: PM_{2.5} (µg/m³) is rounded to one decimal place, PM₁₀ (µg/m³) to an integer, CO (ppm) to one decimal place, SO₂ (ppb) to an integer, and NO₂ (ppb) to an integer.

The AQI breakpoints are then utilized to determine the two breakpoints that contain the concentration.

Table 4: Breakpoints for the AQI

Breakpoints					AQI	Category
PM2.5 ($\mu\text{g}/\text{m}^3$) 24-hour	PM10 ($\mu\text{g}/\text{m}^3$) 24-hour	CO (ppm) 1-hour	SO ₂ (ppb) 1-hour	NO ₂ (ppb) 1-hour	AQI	
0.0 – 12.0	0 – 54	0.0 – 4.4	0 – 35	0 – 53	0 - 50	Good
12.1 – 35.4	55 – 154	4.5 – 9.4	36 – 75	54 – 100	51 – 100	Moderate
35.5 – 55.4	155 – 254	9.5 – 12.4	76 – 185	101 – 360	101 – 150	Unhealthy for Sensitive Groups
55.5 – 150.4	255 – 354	12.5 – 15.4	186 – 304	361 – 649	151 – 200	Unhealthy
150.5 – 250.4	355 – 424	15.5 – 30.4	305 – 604	650 – 1249	201 – 300	Very Unhealthy
250.5 – 350.4	425 – 504	30.5 – 40.4	605 – 804	1250 – 1649	301 – 400	Hazardous
350.5 – 500.4	505 – 604	40.5 – 50.4	805 – 1004	1650 – 2049	401 – 500	Hazardous

The equation used to calculate the air quality index (AQI) is as follows:

$$I_p = \frac{I_{Hi} - I_{Lo}}{BP_{Hi} - BP_{Lo}} (C_p - BP_{Lo}) + I_{Lo}$$

Where:

I_p = the index for pollutant p

C_p = pollutant P's truncated concentration

BP_{Hi} = the breakpoint greater than or equal to C_p

BP_{Lo} = the breakpoint less than or equal to C_p

I_{Hi} = the AQI value corresponding to BP_{Hi}

I_{Lo} = the AQI value corresponding to BP_{Lo}

3.11 System Development

The system development process was divided into three units which are the sensing unit, data processing unit, and web application unit.

3.11.1 Sensing Unit

The sensing unit is comprised of the Atmega328 microcontroller and various sensors for monitoring air pollutants. Various parameters are being monitored such as PM2.5, PM10, CO, CO₂, NO₂, SO₂, temperature, and humidity. In this case, each sensor node contains MQ7, MQ135, MQ136, MiCS4514, PMS7003, and DHT22 sensors to collect the air pollutant parameters. The gathered data are sent to the Atmega328 microcontroller for transmission to the data processing system via a LoRa shield wireless transmission technology.

3.11.2 Data Processing Unit

The data processing unit collects data from the sensor nodes, each of which has a unique ID associated with it. The data processing unit in this system is handled by a Raspberry Pi since it is more powerful and performs at a higher speed than other options. The primary purpose of this device is to collect and analyze air quality data that is collected from a variety of sensor nodes in real-time. The following is a list of the primary functions of the processing system:

- (i) Receive, analyze, process, and store data received from all sensing nodes.
- (ii) Send analyzed data to the web server for data visualization.
- (iii) Calculating the Air Quality Index (AQI)
- (iv) Initiating alarm notification when parameter or AQI exceeds the threshold.

3.11.3 Web Application Unit

The web application unit is used for client-side data presentation and visualization. It includes graphs, gauges, and reports showing real-time data. The web-based application is designed using Hypertext Markup Language (HTML), Cascading Style Sheet (CSS), JavaScript, Bootstrap, a server-side scripting language known as Hypertext Preprocessor (PHP), and a relational database system named My Structured Query Language (MySQL).

Web applications display real-time data collected by the sensing unit and the calculated AQI data. Users of the system are able to monitor air quality results collected by different sensor nodes, getting health hazard notifications and alerts as well as generating different reports concerning air quality readings from sensor nodes.

3.12 System Testing, Validation, and Verification

Throughout the process of designing and developing the system, testing of the system was carried out. Testing was done in phases, beginning with "unit testing," which involves testing individual components of the system; this is followed by "integration testing," "system testing," and "user acceptance testing," respectively.

Verification was carried out in order to establish the level of quality of the system that was developed and to confirm that there were no errors in the system's operation. It was necessary to validate the system in order to check that it lived up to the expectations of the users.

At the end of the development of the system, validations were carried out by setting the system into operation and a selected group of users were involved in the validation process.

3.12.1 System Testing

System testing was conducted using Extreme Programming (XP) Agile methodology. This methodology is a test-driven development. Its principles are simple: the system product is developed through tests. In the XP model of testing, for every phase in the development life cycle, there is a corresponding testing phase. This starts with unit testing, integration testing, system testing, and user acceptance testing.

(i) Unit Testing

Unit testing was done during system development. Each programmed sensor, sensor node, and coordinator device were tested to ensure the efficiency, performance, and validity of the output generated by the sensors and the devices before integrating with other modules. Unit testing was performed in all separate sensors along with performing calibrations of each sensor for verifications of the outputs.

(ii) Integration Testing

In this testing units, modules, and components were logically integrated and tested as a group. The main focus of integration testing was to test the interface and the interactions between units, modules, and components and expose any defects at the time when these components are integrated and need to interact with each other.

(iii) System Testing

System testing was carried out in order to test the system as a whole and with all of its components completely integrated. Integration and testing of the entirety of the system's units, modules, and components were performed in order to validate the system's functionality and performance. The goal was to determine whether or not there are any differences in behavior between the components that are integrated. Testing the system after it has been integrated helps find bugs throughout the entire system.

(iv) User Acceptance Testing

User acceptance testing was performed by the selected group of end users to determine if the system does as it is expected to do, as well as to validate/accept the developed system before the final implementation of the system. This process was done as a final stage of system testing after unit, integration, and system testing. After the user acceptance testing, users were given questionnaires to assess the validity of the system. The responses from the questionnaires were then analyzed as shown in Table 5.

Table 5: User acceptance testing results

No	Acceptance Variable	Strongly Agree	Agree	Neutral	Disagree	Strongly Disagree	Mean Score
1.	The system is easy to use and user-friendly.	17	3	0	0	0	4.85
2.	The web application is compatible with different browsers on different user devices.	4	8	8	0	0	3.80
3.	The system will make it easier for real-time air quality monitoring and make use of collected data for analysis	11	9	0	0	0	4.55
4.	Real-time air quality monitoring data are well presented and easy to understand.	14	5	1	0	0	4.65
5.	Health hazards indication and warnings are very important and useful to residents, miners, and authorities.	9	11	0	0	0	4.45
6.	The system's overall performance has met my expectations, and I have no complaints.	16	4	0	0	0	4.80
7.	I will recommend the use of this system to others.	13	7	0	0	0	4.65

The findings of the system acceptance reveal that the average score for each response was more than 3.80, and these results are a solid sign that the majority of respondents were impressed with the general performance and efficiency of the system.

CHAPTER FOUR

RESULTS AND DISCUSSION

4.1 Results

4.1.1 Findings from Miners and Residents Living Near Mines Areas

The study was conducted to find out the current situation of the air quality and diseases related to air quality as well as the methods used to monitor the air quality of the place. In addition, the study was carried out to evaluate the needs of the proposed system as well as to determine the requirements which will be an acceptable option for all mines regions.

(i) Resident's demographic information

As shown in Table 6, 68 respondents which are equal to 70.8% of the 96 respondents in this study were male, while 28 equivalents to 29.2% were female. The study involves 6 villages of the Bulyanhulu ward of which 25 respondents equivalent to 26% were from Kakola village. The maximum age range was 60 and above, while the lowest age range was between 14 to 17. The majority of respondents were between the ages of 31 to 45, accounting for 51% of the total sample size. The study finds that 50% of respondents have been staying in their villages for more than 10 years. Furthermore, the findings revealed that the majority of residents had a secondary education, followed by those with after-secondary education (certificate and diploma).

Table 6: Respondents' demographic information

Demographic Characteristics		Respondents	Percentage (%)
Gender	Male	68	70.8
	Female	28	29.2
Age (in Years)	14-17	3	3.1
	18-30	18	18.8
	31-45	49	51
	46-60	23	24
	60 and above	3	3.1
	Education	Illiterate	2
	Primary education	14	14.6
	Secondary education	56	58.3
	After secondary education	18	18.8
	University	6	6.8
Residence	Kakola	25	26
	Namba 9	19	19.8
	Bushing'we	13	13.5
	Busulwangili	13	13.5
	Lwabakanga	14	14.6
	Busindi	12	12.5
Residence time	6 months to 1 year	3	3.1
	1 to 5 years	17	17.5
	6 to 10 years	28	29.2
	More than 10 years	48	50

(ii) Respondents' awareness of mining activities in their area

The study sought to ascertain respondents' general knowledge of mining activities in their area. All respondents agreed to be aware of the mining activities in their areas and responded that the method of extraction used by the mining company is underground mining. As it is shown in Fig. 16, out of 96 respondents 81.3% responded that the methods of operation used have some effects on air pollution, while 5.2% responded that there is no effect, and 13.5% responded that they don't know whether there is effect or not.

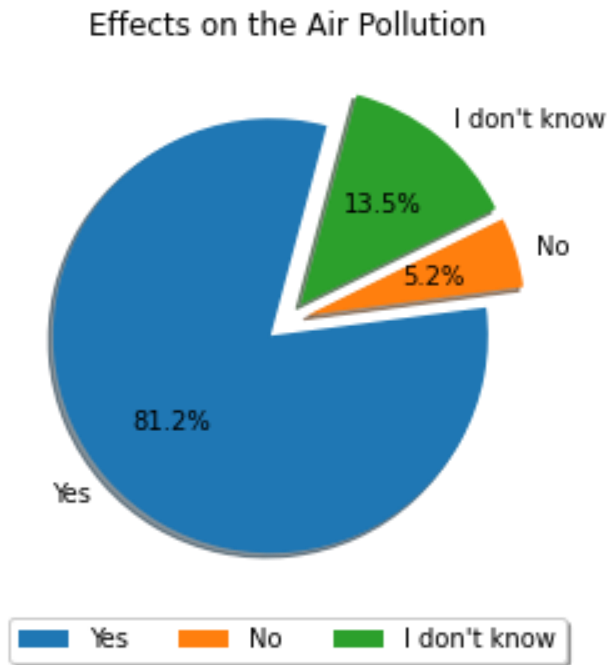

Figure 16: Respondents' awareness of the effects of mining activities on air pollution

(iii) Sources of air pollution

The study revealed that, out of many factors, 88% of responses show the sources of air pollution to be caused by blasting, 84% being caused by drilling, 49.4% material handling, 83.1% processing, 78.3% burning, 50.6% heavy machines, 74.7% transportation, 69.9% wind erosion, and 59% waste disposal.

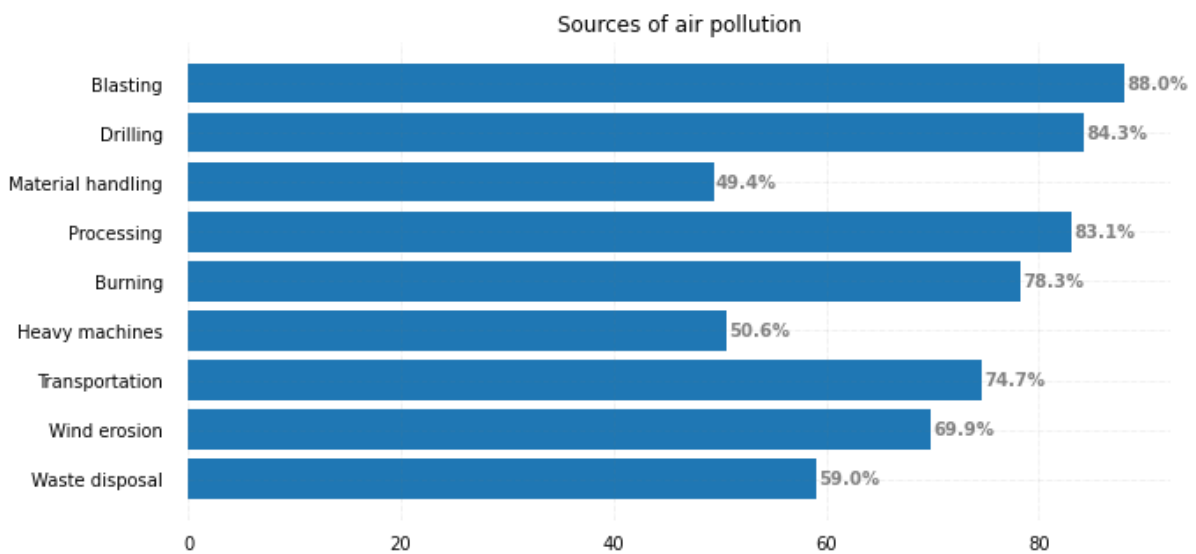

Figure 17: Respondents' responses for sources of air pollution

(iv) Respondents' perspective on air quality monitoring

The study sought to ascertain air quality monitoring and mitigation methods currently being used to monitor air quality and reduce or mitigate the adverse air quality effects of mining activities and see if it meets the demands. The study revealed that out of 96 respondents, 74% responds that there are no monitoring devices/methods currently being used to monitor air quality. Ten-point four percent (10.4%) indicated that there are some methods used to mitigate the air pollution level. Most of them mentioned re-afforestation as a method used to mitigate air pollution. Fifteen-point six percent (15.6%) responded to have no idea whether there are monitoring/mitigation devices/methods currently being used.

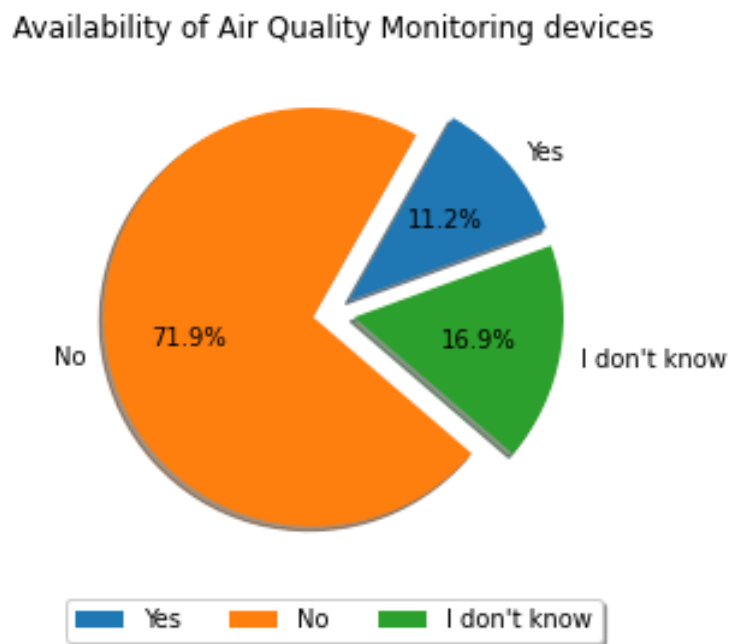

Figure 18: Respondents' perspectives on air quality monitoring

(v) Diseases people usually suffer from or contact

The study focused on knowing the air pollution-related diseases that people usually suffer from or contacted. Ninety-one-point seven percent (91.7%) of responses show that most people suffer from coughing, followed by irritation of the eyes, nose, and throat 83.3%, followed by chest pain or difficulty in breathing (acute respiratory) 81.3% as shown in Fig. 19.

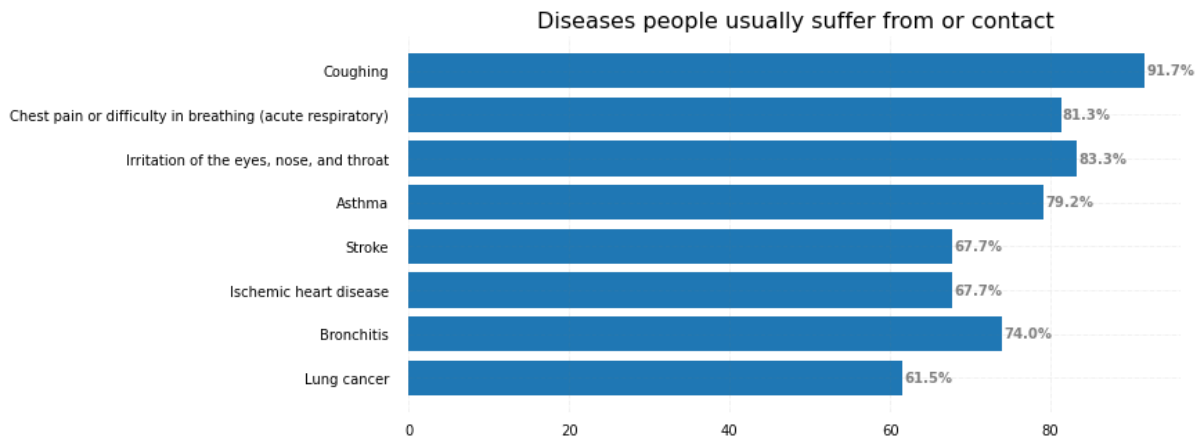

Figure 19: Diseases people usually suffer from or contact

4.1.2 Functional and Non-Functional Requirements for the proposed system

The requirements for the proposed system were analyzed and grouped into functional and non-functional requirements. The functional requirements define the functions that the system has to be able to carry out in order to provide the service that the user requires. The properties of the system that must be met for it to work properly are explained by non-functional requirements. Concerns regarding scalability, availability, reliability, and security are examples of the types of requirements that fall into the non-functional group. In this study, both primary and secondary information were utilized in order to ascertain the necessary functional and non-functional features. The primary sources consisted of questionnaires as well as secondary data that was collected through reading various papers, paperwork, manuals, and other easily available resources. The requirements for the proposed system are broken down into both their functional and non-functional aspects and summarized in Tables 7 and 8.

Table 7: Functional requirements

Requirement	Description
Air quality monitoring parameters	The system should be able to monitor carbon monoxide, carbon dioxide, nitrogen dioxide, sulfur dioxide, particulate matter PM2.5/PM10, temperature, and humidity
Air Quality Index (AQI) calculation	The system should be able to calculate the Air Quality Index (AQI) and provide alerts and warning messages when the AQI exceeds the threshold.
Health risk indication	The system should indicate the possibility of health risks based on when the Air Quality Index (AQI) exceeds the threshold.
Recommendation	The system should provide a recommendation which is just a cautionary message, when the AQI exceeds the threshold.
Ability to work online	The system should be able to be accessed via the internet to allow distant users to monitor air quality remotely using their computers or mobile phones browsers.
Ability to work offline	The system should be able to work offline to allow users who are not connected to the internet to be able to monitor air quality and be notified with a warning alert when the AQI exceeds the threshold.
Availability of trend reports	The system should be able to provide air quality trending reports to allow authorities, policymakers, and researchers to act promptly.
Monitor multiple nodes	The system should provide users with the ability to monitor multiple nodes on the same dashboard.
Power supply flexibility	The system should be flexible by ensuring that it can be powered by electricity, battery, or solar panel for cost-effective power.

Table 8: Non-Functional requirements

Requirement	Description
Reliability	The system should be up and running all the time when users want to interact with it, with very minimal downtime.
Usability	The system should be simple, easy, and user-friendly to allow all kinds of users to interact with it.
Scalability	The system must be scalable enough to support more users at the same time while maintaining optimal performance. It should also be flexible to accommodate new features and functions with minor modifications.
Response time	The system should be able to accommodate all users' requests within a short time.
Robustness	The system should ensure that it doesn't crash at the slightest disturbance, and it must ensure that no data is lost after a system failure or restart.
Security	The system should ensure the protection of data against any attack.
Compatibility	The system should be compatible with all browsers operating on a mobile phone or a computer.

4.1.3 System Implementation Overview

The air quality monitoring and health hazards indication system, was developed and implemented successfully as sensor node and gateway node. The experimental findings and validation were also performed. System testing was performed several times to avoid obtaining incorrect data. Calibration for all sensors was performed to ensure reliable air quality data. The sensor nodes implemented as standalone systems powered by a lithium-ion battery charged by a solar panel mounted to the system to enable the system to run continuously and being able to obtain timely information. Sensor nodes transmit collected data to the coordinator through the LoRa shields. The data collected by sensors (CO, CO₂, NO₂, SO₂, PM2.5/PM10, Temperature, and Humidity) are then stored in the cloud. The Thing-Speak IoT server is then utilized to visualize data measured by the sensors. The real-time results can also be observed

simultaneously on a web-based dashboard where all sensor readings are displayed, the AQI is calculated, and the health hazards warning is indicated.

The information regarding air quality parameters is made available in ThingSpeak in real-time as soon as the devices are turned on. Each sensor node is assigned a unique channel ID in the ThingSpeak IoT server. Different fields represent different parameters, and the data are updated after every 10 seconds.

The system was implemented for a duration of 6 weeks to monitor air quality of Bulyanhulu ward. The designed sensor nodes were only two sensor nodes and one coordinator. In order to obtain reliable results based of different criteria such as spatial variation, and temporal variance of different locations, the sensor nodes were moved from one point to another after a duration of not less than 5 days. The results were acquired during the system fabrication at the Bulyanhulu ward. The sample data of each of the eight parameters that were obtained include PM2.5 104.16 $\mu\text{g}/\text{m}^3$, PM10 114.13 $\mu\text{g}/\text{m}^3$, CO 0.16 ppm, CO₂ 217.43 ppm, NO₂ 0.13 ppb, SO₂ 0.92 ppm, temperature 30°C, humidity 65%. As shown in Fig. 20 (20a – to - 20h), the data from each sensor (field) is synced and shown in real-time as ThingSpeak charts. Air quality levels are presented in graphs for each parameter, taking into account that the air condition might rapidly change. There are several benefits of using ThingSpeak as an IoT platform. The ThingSpeak IoT platform is simple to configure and match with the linked sensors. ThingSpeak may be used to display real-time data as charts, gauges, graphs, or numerical values. ThingSpeak may provide a graph showing the historical trend of a given period. ThingSpeak offers MATLAB data processing and visualization. ThingSpeak data can be publicly available using a channel name or channel ID.

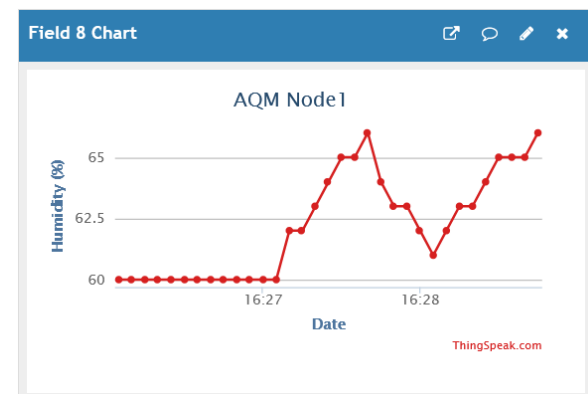
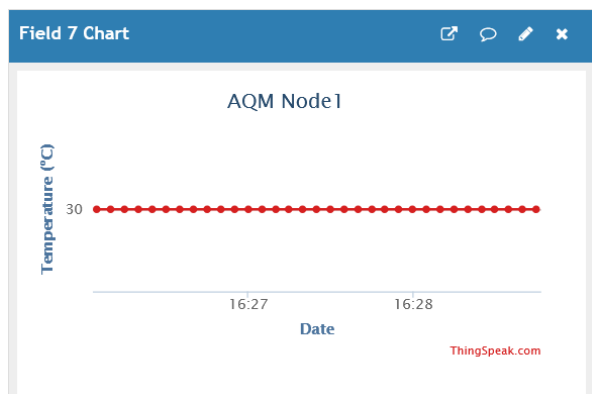
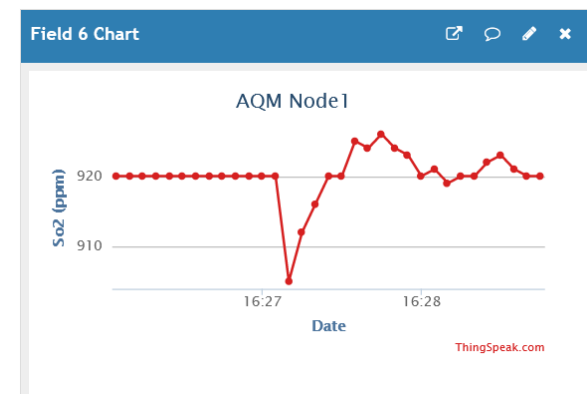
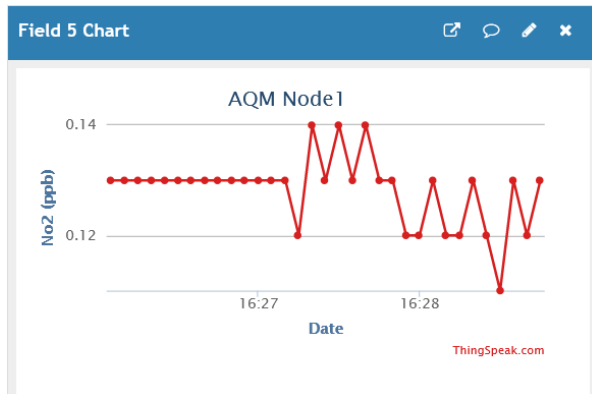
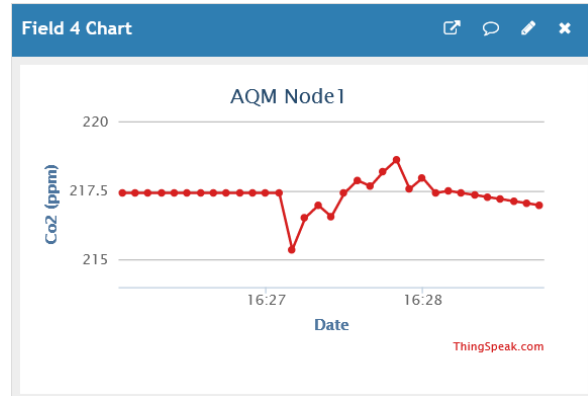
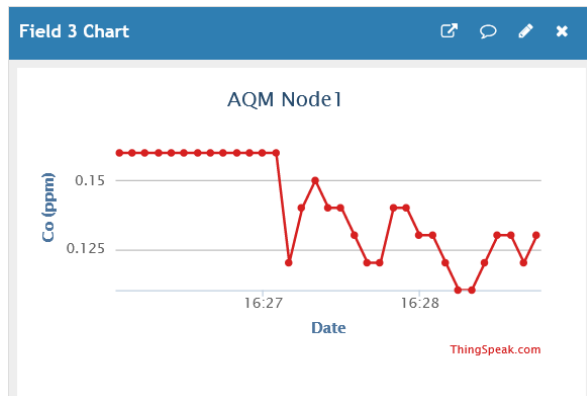
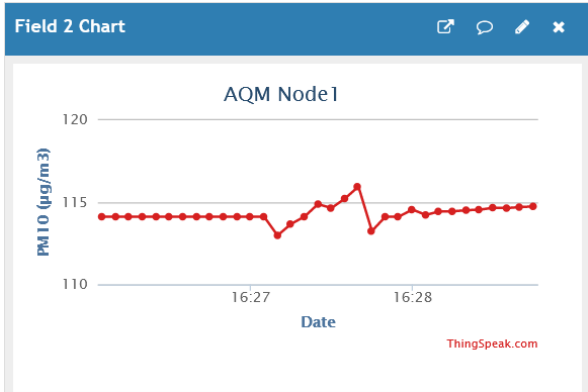
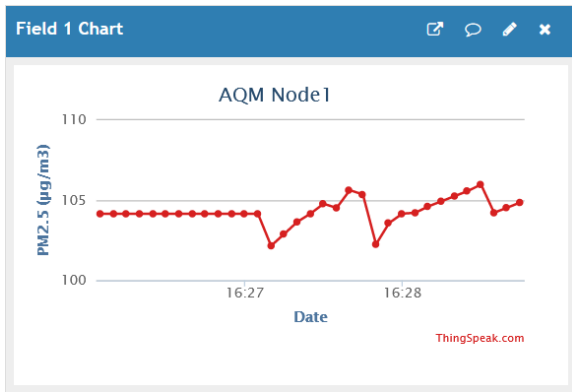

Figure 20: (a) PM2.5, (b) PM10, (c) CO, (d) CO2, (e) NO2, (f) SO2, (g) temperature and (h) humidity

4.1.4 Hardware Design and Implementation

In order to improve the system's stability and get rid of interference, a printed circuit board was produced to link various electrical and electronic components by means of conductive tracks. LoRa modules and sensors are soldered onto the PCB in order to link them together. The General Purpose Input/Output (GPIO) header is used to connect the modules and sensors to the microcontroller.



Figure 21: System physical hardware design

4.1.5 Performance Evaluation

Prior to deploying the system in a live environment, a performance evaluation was carried out to verify system stability. Our prototype was developed with four major constraints: multi-sensing ability, sustainable operation, long-range data transmission, and health hazards indication. The proposed system was developed to address the four constraints. The system integrated with the PV system as the primary focus for assuring long-term operation. All sensors are interconnected with the microcontroller in a PCB enclosure to ensure the multi-functionality of the system. The results are well analyzed for indication of health hazards. The aforementioned qualities when combined help to increase system performance. Furthermore, the appropriate selection of IoT servers makes information more available to the public, giving a perfect solution to challenges linked with AQI monitoring. The selection of LoRa technology is the best solution to ensure long-range wireless communication as it demonstrates the

capability to cover up to 10 km in the line-of-sight radius. However, the distance can reduce to 2km in outdoor environments with obstacles. With all the examining factors, we confidently determined LoRa technology as the ideal choice for developing the IoT-based outdoor AQMS.

4.1.6 The Web-based System

The web-based system was developed to enable users to easily monitor real-time air quality data. The dashboard of the web system was developed to visualize the air pollutants parameters (CO, CO₂, NO₂, SO₂, PM_{2.5/10}, Temperature, Humidity) of each sensor node. The web-based system is also displaying the Air Quality Index (AQI) level and indicates the health hazards in case the AQI exceeds the threshold as well as the leading pollutant and indicates the possible diseases that can be caused by getting exposed to such environments.

Figure 22 shows the login page of the air quality monitoring system. Users are required to provide their correct credentials that is username and password to be able to gain access to the system. Unregistered users are required to first register themselves into the system before they can attempt to login to the system. Figure 23 shows the registration form which requires unregistered users to provide their relevant information such as first and last name, gender, email, and password in order to be registered to the system. The system allows only registered users to gain access to viewing the real-time air quality data.



Login

Username

Password

[Login](#)

Don't have an account? [Register here](#)

Figure 22: Web-based air quality monitoring system, Login page

Register Here

First Name

Last Name

Gender

Email

Password

Re-Password

[Register](#)

Do you have an account? [Sign in here](#)

Figure 23: Web-based air quality monitoring system, Registration page

The dashboard of a real-time air quality monitoring system displays the summary of a real-time sensor readings from the two sensor nodes (Node 1, and Node 2). The real-time data are updated to the web-based system after every 10 seconds. The dashboard shows a summary of all the parameter readings and the Air Quality Index (AQI) together with the health hazards as shown in Fig. 24.

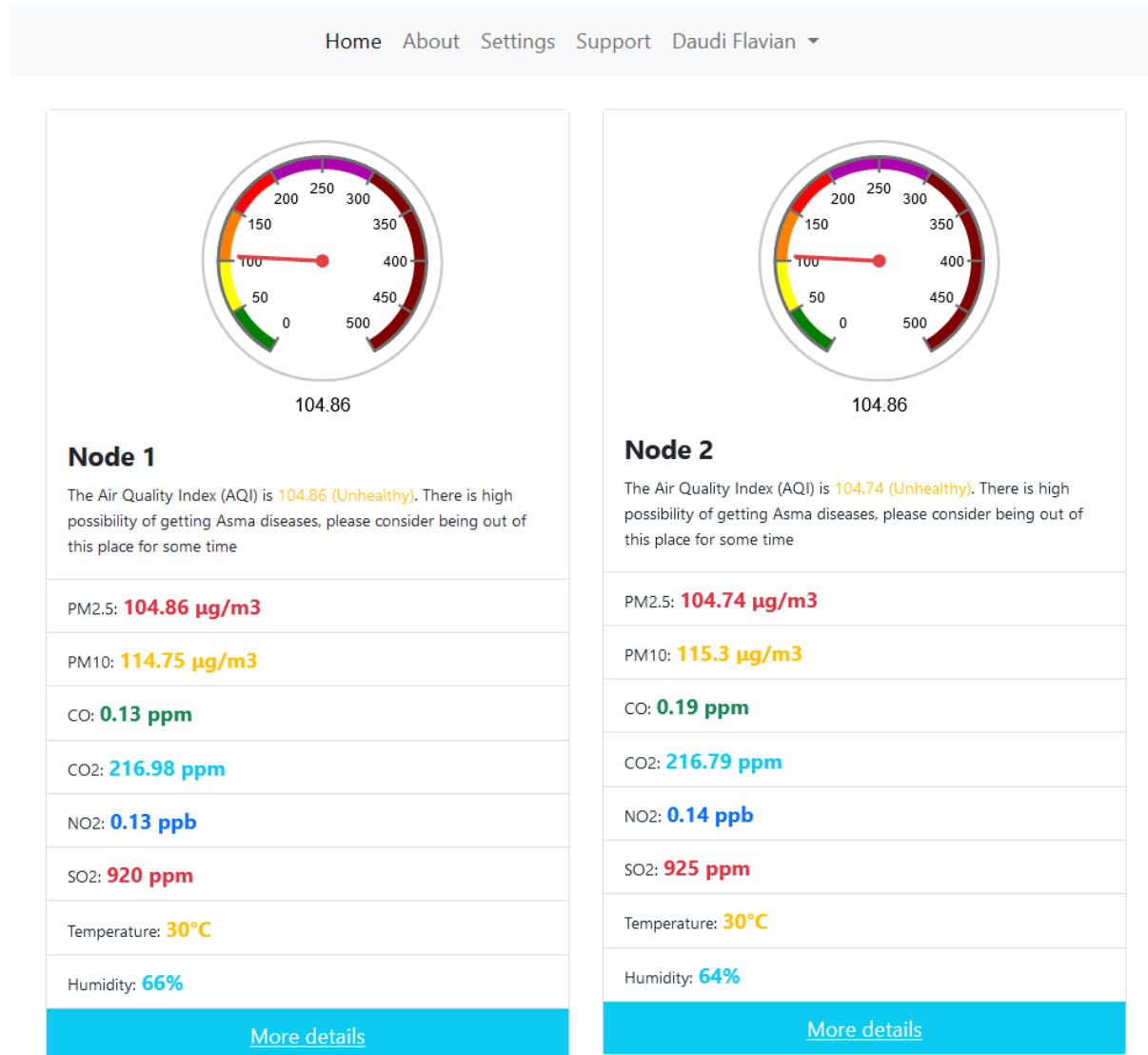

Figure 24: Web-based real-time air quality monitoring system, Dashboard page

More visualization of the data and graphs can be accessed via a more details button link at the bottom of each sensor node summary in the dashboard. More details page of each sensor node, contains more information and visualization of data for each parameter. The page displays the gauge readings of each parameter (PM2.5, PM10, CO, CO₂, NO₂, SO₂, Temperature, and Humidity) as well as the real-time graphs of each parameter as indicated in Fig. 25, for sensor

Node-1, and Fig. 26, For sensor Node-2. This helps users of the system to be able to visualize more the air quality trends of the place and being able to act promptly.

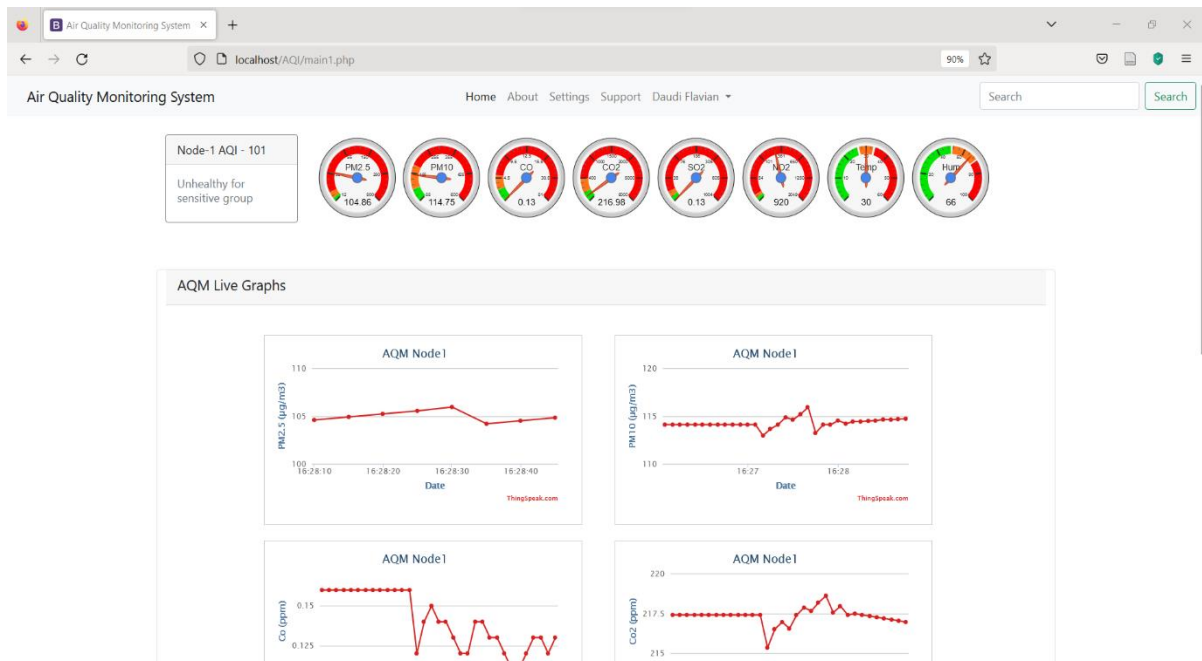

Figure 25: A web-based air quality monitoring system, Node-1 dashboard



Figure 26: A web-based air quality monitoring system, Node-2 dashboard

4.1.7 Health Hazards Indication

The information on Air Quality Index (AQI) that can be gleaned from the data collected by the various sensors is quite helpful. The Air Quality Index (AQI) serves as an indicator that determines the quality of the air around us by comparing it to various standards, criteria, and thresholds. The state of the air, as indicated by the AQI, can be categorized depending on a variety of variables and indications.

The levels, which are based on the AQI, are supposed to be reflective of how clean or dangerous the air pollution is, according to the AQI guidelines. The air quality may be set at a variety of various levels thanks to the capabilities of our technology.

If the air quality index (AQI) value is between 0 and 50, it is regarded as having "good" quality. If the AQI is between 51 and 100, the air quality is considered to be moderate. If the Air Quality Index (AQI) is between 101 and 150, the air quality is considered to be "Unhealthy for sensitive groups." If the AQI is between 151-200, it would indicate that the air around you are "Unhealthy." The AQI level between 200 and 300 are considered to be in the "Very unhealthy" level. The last category, "Hazardous," is assigned when the air quality in the surrounding area is poor and the related AQI value is 301 or higher.

The developed system is able to calculate the AQI and flag potential health risks in accordance with the criteria established by the WHO for air quality. When the system detects that the current AQI level is higher than the predefined threshold, it will generate an alert notification.

4.1.8 System Implementation Challenges and Mitigations

During system implementation a couple of non-technical challenges were faced, these challenges include:

Physical security of devices, this was among the biggest challenge during system implementation and lead to face a challenge of monitoring air quality during day and dismantle devices during night for three consecutive days.

This challenge was mitigated by implementing measures such as implementing secure mounting, robust enclosure, and talking to askari (sungusungu) to help protect the devices taking into consideration that ensuring physical security of these devices is crucial to maintain the integrity and continuous operation of the air quality monitoring system.

4.2 Discussion

The developed real-time IoT-based air quality monitoring and health hazards indicator system simplifies the air quality monitoring process. The findings indicate that the AQI level is highly determined by the proximity of mining operations to a particular location. Our study revealed both geographical and temporal variances at the various node placement sites, particularly Kakola, Namba 9, and the rest. This variation may imply that health risks associated with PM_{2.5}, PM₁₀, CO, CO₂, SO₂, NO₂, Temperature, and Humidity exposure, such as asthma, lung cancer, heart disease, respiratory illness, and cardiovascular disease, may also vary within a community based on its distance from mining operations and pollutant sources. In addition, our findings support the hypothesis that sources from mining activities and vehicle traffic affect PM_{2.5}, PM₁₀, CO, CO₂, SO₂, and NO₂ concentrations. These findings highlight the residents' concerns about the effects of air pollutants from mining activities in the Bulyanhulu area.

The average AQI level for PM_{2.5/10}, CO, CO₂, SO₂, NO₂, temperature, and humidity concentrations at two monitoring nodes in separate locations ranged from 25 to 90. The average level at Kakola and Namba 9 is between 35 and 90. The average daily AQI readings at Bushing'we, Busulwangili, Lwabakanga, and Busindi ranged from 25 to 65. In close proximity to mining operations, such as Kakola and Namba 9, Particulate Matter (PM) concentrations were greater than in places further away from mining operations. According to a study conducted, mining operations are the major contributor to Particulate Matter (PM) in these areas. The primary source of Particulate Matter (PM) exposure in and around the Bulyanhulu ward was identified as mining. There may be an increase in particulate matter (PM) concentrations in the vicinity of mining operations and as a result of materials transportation activities involving truck traffic.

Moreover, we detected variations in the mean concentrations of PM_{2.5}, PM₁₀, CO, CO₂, SO₂, NO₂, Temperature, and Humidity between day and night. Observations indicate that concentrations are high during the day when there are many activities and traffic, but low at night when there are fewer activities. The concentrations of PM_{2.5}, PM₁₀, CO, CO₂, SO₂, NO₂, Temperature, and Humidity began to rise in the morning as a result of direct dust resuspending by road traffic and mining activities. The study revealed that concentrations of PM_{2.5}, PM₁₀, CO, CO₂, SO₂, NO₂, Temperature, and Humidity start to drop slightly during sunset and increase gradually between late morning and late afternoon.

CHAPTER FIVE

CONCLUSION AND RECOMMENDATIONS

5.1 Conclusion

The consequences of air quality may not be noticed immediately, but its long-term impact on human health cannot be ignored. This study described the deployment of an IoT-based air quality monitoring and health hazard indicator system that operates in real-time. The system uses LoRa technology for long-distance connectivity, a PV system for autonomous operation, and sensors for measuring PM_{2.5}, PM₁₀, NO₂, SO₂, CO, CO₂, temperature, and humidity concentrations. The air quality data are transferred to the Thing-Speak IoT server for display and storage, and users may simply access the information. The technology enables wide-area air quality monitoring.

The system has the potential to fulfill a significant requirement by monitoring the quality of the air that residents and miners breathe in, which is characterized by higher levels of pollutants that have an impact on a large number of people. People are made aware of potentially hazardous amounts of these detected contaminants as a means of providing an indicator of potential health hazards.

5.2 Recommendations

The goals set forth at the outset of this study have been met with success. However, more studies are required. The goal of this project was to utilize LoRa technology and sensors to implement a real-time IoT-based air quality monitoring and health hazards indicator system and enhancing real-time data accessibility. A variety of testing scenarios demonstrated the system's functioning and efficacy while generating deeper insights.

To improve data accuracy, researchers may deploy more sensors while developing other AQMS. New performance measures can be performed to improve analytic findings from a methodological standpoint. Another prospective area of research is the influence of AQMS on healthcare, particularly during pandemics, especially in areas with population and mining activities. A prediction approach may also be used to forecast the future AQI based on the data gathered over a certain period. A sufficient number of synthesized nodes may be deployed as a LoRa network allowing users access to considerably more information.

REFERENCES

- AbdulWahhab, R. S. (2019). Air Quality System Using IoT for Indoor Environmental Monitoring. *Proceedings of the 2019 5th International Conference on Computer and Technology Applications*, 184–188. <https://doi.org/10.1145/3323933.3324088>.
- Ada, L. (2022). DHT11, DHT22 and AM2302 Sensors. *Adafruit Learning System*. <https://learn.adafruit.com/dht/overview>.
- Al-Zewairi, M., Biltawi, M., Etaiwi, W., & Shaout, A. (2017). Agile Software Development Methodologies: Survey of Surveys. *Journal of Computer and Communications*, 05(05), 74–97. <https://doi.org/10.4236/jcc.2017.55007>.
- Burnett, R., Chen, H., Szyszkowicz, M., Fann, N., Hubbell, B., Pope, C. A., Apte, J. S., Brauer, M., Cohen, A., Weichenthal, S., Coggins, J., Di, Q., Brunekreef, B., Frostad, J., Lim, S. S., Kan, H., Walker, K. D., Thurston, G. D., Hayes, R. B., & Spadaro, J. V. (2018). Global estimates of mortality associated with long-term exposure to outdoor fine particulate matter. *Proceedings of the National Academy of Sciences*, 115(38), 9592–9597. <https://doi.org/10.1073/pnas.1803222115>.
- Chandra, I., Santoso, M., Inomata, Y., & Seto, T. (2021). Utilization of microsensors for air-quality monitoring systems. In *Handbook of Advanced Approaches Towards Pollution Prevention and Control*, 307–324. Elsevier. <https://doi.org/10.1016/B978-0-12-822121-1.00015-1>.
- Chen, J., & Hoek, G. (2020). Long-term exposure to PM and all-cause and cause-specific mortality: A systematic review and meta-analysis. *Environment International*, 143, 105974. <https://doi.org/10.1016/j.envint.2020.105974>.
- Choiri, A., Mohammed, M. N., Al-Zubaidi, S., Al-Sanjary, O. I., & Yusuf, E. (2021). Real Time Monitoring Approach for Underground Mine Air Quality Pollution Monitoring System Based on IoT Technology. *2021 IEEE International Conference on Automatic Control & Intelligent Systems*, 364–368.
- Cohen, A. J., Brauer, M., Burnett, R., Anderson, H. R., Frostad, J., Estep, K., Balakrishnan, K., Brunekreef, B., Dandona, L., Dandona, R., Feigin, V., Freedman, G., Hubbell, B., Jobling, A., Kan, H., Knibbs, L., Liu, Y., Martin, R., Morawska, L., Forouzanfar, M.

- H. (2017). Estimates and 25-year trends of the global burden of disease attributable to ambient air pollution: An analysis of data from the Global Burden of Diseases Study 2015. *The Lancet*, 389(10082), 1907–1918. [https://doi.org/10.1016/S0140-6736\(17\)30505-6](https://doi.org/10.1016/S0140-6736(17)30505-6).
- Components101. (2022). MQ-135 Gas Sensor for Air Quality. *Components101*. <https://components101.com/sensors/mq135-gas-sensor-for-air-quality>.
- Daud, S., Yang, T. S., Romli, M. A., Ahmad, Z. A., Mahrom, N., & Raof, R. A. A. (2018). Performance Evaluation of Low Cost LoRa Modules in IoT Applications. *IOP Conference Series: Materials Science and Engineering*, 318, 012053. <https://doi.org/10.1088/1757-899X/318/1/012053>.
- DFRobot. (2022). Gravity: MEMS Gas Sensor MiCS-4514. *DFRobot*. https://wiki.dfrobot.com/_SKU_SEN0377_Gravity_MEMS_Gas_Sensor_CO_Alcohol_NO2_NH3_I2C_MiCS_4514.
- Dhingra, S., Madda, R. B., Gandomi, A. H., Patan, R., & Daneshmand, M. (2019). Internet of Things Mobile–Air Pollution Monitoring System (IoT-Mobair). *IEEE Internet of Things Journal*, 6(3), 5577–5584. <https://doi.org/10.1109/JIOT.2019.2903821>.
- Espruino. (2017). PMS7003 Particulate matter. *sensor—Espruino*. <https://www.espruino.com/PMS7003>.
- Firdhous, M. F. M., Sudantha, B. H., & Karunaratne, P. M. (2017). IoT enabled proactive indoor air quality monitoring system for sustainable health management. *2017 2nd International Conference on Computing and Communications Technologies*, 216–221. <https://doi.org/10.1109/ICCCT2.2017.7972281>.
- Fuertes, W., Carrera, D., Villacis, C., Toulkeridis, T., Galarraga, F., Torres, E., & Aules, H. (2015). Distributed System as Internet of Things for a New Low-Cost, Air Pollution Wireless Monitoring on Real Time. *2015 IEEE/ACM 19th International Symposium on Distributed Simulation and Real Time Applications*, 58–67.
- HabariLeo. (2021, November 18). Habari. <https://habarileo.co.tz/habari/2021-11-18619660e614070.aspx#>.

- Hanwei. (2022). MQ7 SENSOR Datasheet pdf-GAS SENSOR. *Equivalent, Catalog. Datasheetpdf*. <https://datasheetpdf.com/pdf/694312/Hanwei/MQ7/1>.
- Hareva, D. H., & Marsyaf, C. D. P. (2019). Air quality monitoring at Pelita Harapan university using the MQ-135 sensor. *Proceedings of the 3rd International Conference on Telecommunications and Communication Engineering*, 6–10.
- HPAP. (2019). Health and Pollution Action Plan United Republic of Tanzania. *Health and Pollution Action Plan*.
- Huangfu, P., & Atkinson, R. (2020). Long-term exposure to NO₂ and O₃ and all-cause and respiratory mortality: A systematic review and meta-analysis. *Environment International*, 144, 105998. <https://doi.org/10.1016/j.envint.2020.105998>.
- Jo, J., Jo, B., Kim, J., Kim, S., & Han, W. (2020). Development of an IoT-Based Indoor Air Quality Monitoring Platform. *Journal of Sensors*, 2020, 1–14.
- Jones, W. (2019). Introduction to 20x4 LCD Module. *The Engineering Projects*. <https://www.theengineeringprojects.com/2019/12/introduction-to-20-x-4-lcd-module.html>
- Kampa, M., & Castanas, E. (2008). Human health effects of air pollution. *Environmental Pollution*, 151(2), 362–367. <https://doi.org/10.1016/j.envpol.2007.06.012>.
- Kumar, K., Zindani, D., & Davim, J. P. (2020). Design Thinking to Digital Thinking. *Springer International Publishing*. <https://doi.org/10.1007/978-3-030-31359-3>.
- Manikannan, G., Vijayalakshmi, T., & Prabakaran, P. (2019). Mobile Air Pollution Monitoring System using Internet of Things (IoT). *International Journal of Science & Engineering Development Research*.
- Murray, C. J. L., Aravkin, A. Y., Zheng, P., Abbafati, C., Abbas, K. M., Abbasi-Kangevari, M., Abd-Allah, F., Abdelalim, A., Abdollahi, M., Abdollahpour, I., Abegaz, K. H., Abolhassani, H., Aboyans, V., Abreu, L. G., Abrigo, M. R. M., Abualhasan, A., Abu-Raddad, L. J., Abushouk, A. I., Adabi, M., & Lim, S. S. (2020). Global burden of 87 risk factors in 204 countries and territories, 1990–2019: A systematic analysis for the

- Global Burden of Disease Study 2019. *The Lancet*, 396(10258), 1223–1249. [https://doi.org/10.1016/S0140-6736\(20\)30752-2](https://doi.org/10.1016/S0140-6736(20)30752-2).
- Nasir, S. Z. (2017). Introduction to ATmega328. *The Engineering Projects*. <https://www.theengineeringprojects.com/2017/08/introduction-to-atmega328.html>.
- Nawazi, F. (2021). MQ136 Hydrogen Sulfide Gas Sensor Module. *Circuits DIY*. <https://www.circuits-diy.com/mq136-hydrogen-sulfide-gas-sensor-module>.
- Nirosha, K., Durgasree, B., & Shirisha, N. (2017). IoT based air pollution monitoring system. *International Journal of Current Engineering and Scientific Research*.
- OpenAQ. (2022). OpenAQ. *OpenAQ*. <https://openaq.org>.
- Orellano, P., Reynoso, J., & Quaranta, N. (2021). Short-term exposure to sulphur dioxide (SO₂) and all-cause and respiratory mortality: A systematic review and meta-analysis. *Environment International*, 150, 106434.
- Orellano, P., Reynoso, J., Quaranta, N., Bardach, A., & Ciapponi, A. (2020). Short-term exposure to particulate matter (PM₁₀ and PM_{2.5}), nitrogen dioxide (NO₂), and ozone (O₃) and all-cause and cause-specific mortality: Systematic review and meta-analysis. *Environment International*, 142, 105876.
- Patel, H. (2022). DS3231 RTC (Real Time Clock) Interfacing with Arduino to build DIY Digital Clock. <https://circuitdigest.com/microcontroller-projects/interfacing-ds3231-rtc-with-arduino-and-diy-digital-clock>.
- Peters, R., Ee, N., Peters, J., Booth, A., Mudway, I., & Anstey, K. J. (2019). Air Pollution and Dementia: A Systematic Review. *Journal of Alzheimer's Disease*, 70(s1), S145–S163. <https://doi.org/10.3233/JAD-180631>
- Rane, M. S., Naik, A. R., & Vachhani, K. (2018). Real-time AQI Monitoring System: An Economical Approach Using Wireless Sensor Network. *2018 9th International Conference on Computing, Communication and Networking Technologies (ICCCNT)*, 1–6. <https://doi.org/10.1109/ICCCNT.2018.8493676>.
- Roy, R. (2016). The cost of air pollution in Africa. *Organization for Economic Co-operation and Development*. <https://doi.org/10.1787/5jlqzq77x6f8-en>.

- Saha, D., Shinde, M., & Thadeshwar, S. (2017). IoT based air quality monitoring system using wireless sensors deployed in public bus services. *Proceedings of the Second International Conference on Internet of Things, Data and Cloud Computing*, 1–6. <https://doi.org/10.1145/3018896.3025135>.
- Schwegler, F. (2006). Air quality management: a mining perspective. *WIT Transactions on Ecology and the Environment*, 86, 205-212.
- Suryateja. (2018). Use a buzzer module (piezo speaker) using Arduino UNO. *Arduino Project Hub*. <https://create.arduino.cc/projecthub/SURYATEJA/use-a-buzzer-module-piezo-speaker-using-arduino-uno-89df45>.
- Truong, T. P., Nguyen, D. T., & Truong, P. V. (2021). Design and Deployment of an IoT-Based Air Quality Monitoring System. *International Journal of Environmental Science and Development*, 12(5), 139–145. <https://doi.org/10.18178/ijesd.2021.12.5.1331>.
- UNICEF. (2019). Silent suffocation in Africa: Air pollution is a growing menace. <https://www.unicef.org/reports/silent-suffocation-in-africa-air-pollution-2019>.
- Vohra, K., Vodonos, A., Schwartz, J., Marais, E. A., Sulprizio, M. P., & Mickley, L. J. (2021). Global mortality from outdoor fine particle pollution generated by fossil fuel combustion: Results from GEOS-Chem. *Environmental Research*, 195, 110754. <https://doi.org/10.1016/j.envres.2021.110754>.
- World Health Organization. (2016). Ambient air pollution: A global assessment of exposure and burden of disease. *World Health Organization*. <https://apps.who.int/iris/handle/10665/250141>.
- World Health Organization. (2020). WHO report on cancer: Setting priorities, investing wisely and providing care for all. *World Health Organization*. <https://apps.who.int/iris/handle/10665/330745>.
- World Health Organization. (2021). WHO global air quality guidelines: Particulate matter (PM_{2.5} and PM₁₀), ozone, nitrogen dioxide, sulfur dioxide and carbon monoxide. *World Health Organization*. <https://apps.who.int/iris/handle/10665/345329>.

- Wu, D., Xiao, T., Liao, X., Luo, J., Wu, C., Zhang, S., Li, Y., & Guo, Y. (2020). When Sharing Economy Meets IoT: Towards Fine-grained Urban Air Quality Monitoring through Mobile Crowdsensing on Bike-share System. *Proceedings of the ACM on Interactive, Mobile, Wearable and Ubiquitous Technologies*, 4(2), 1–26. <https://doi.org/10.1145/3397328>.
- Zheng, X., Orellano, P., Lin, H., Jiang, M., & Guan, W. (2021). Short-term exposure to ozone, nitrogen dioxide, and sulphur dioxide and emergency department visits and hospital admissions due to asthma: A systematic review and meta-analysis. *Environment International*, 150, 106435. <https://doi.org/10.1016/j.envint.2021.106435>.

APPENDICES

Appendix 1: Poster Presentation



Real-time IoT-based air quality monitoring and health hazards indicator system for mines regions: a case study of Bulyanhulu

Nelson Mandela African Institution of Science and Technology

Daudi Flavian, Michael Kisangiri (PhD), Ramadhani Sinde (PhD)

Email: flaviand@nm-aist.ac.tz, michael.kisangiri@nm-aist.ac.tz, ramadhani.sinde@nm-aist.ac.tz



ABSTRACT

This study proposes a reliable and long-range (LoRa) wireless sensing system that collects air quality data in real-time and updates it on the cloud. The developed real-time IoT-based air quality monitoring system for mines region is composed of numerous sensors (MQ7, MQ135, MQ136, MICS4514, PMS7003), Raspberry Pi, ATmega328 microcontroller, LoRa shields, and the Thingspeak IoT server. The system collects air pollutants such as PM2.5, PM10, CO, NO2, SO2, CO2, temperature, and related humidity. The system is self-contained, using a solar charger shield to link a photovoltaic solar panel to a rechargeable battery for continuous operation. The smart sensing device is constantly monitoring air quality and uploading the results to a cloud via the coordinator node and the LoRa gateway shield, which in turn uploads the information to the Thingspeak IoT server. The data collected are processed to calculate the Air Quality Index (AQI), which is then analyzed to generate early warnings and an indication of diseases and dangerous health hazards when exposed to such environments for a certain time. The results are displayed on a developed web-based dashboard so that users can easily access and visualize the results. This system is reliable for monitoring various air quality indicators and transmitting the data in real time via the internet.

INTEGRATED SOLUTION

- Wireless Sensor Network for Air Quality Monitoring.
- LoRa technology for long-range wireless communication.
- Web application
- Cloud Platform for data visualization
- AQI calculation
- Health hazards indication
- Real-time notifications

BENEFITS

- Monitoring the quality of the air in real-time by using low-power sensors and a communication network.
- Displaying air quality data to stakeholders in real-time.
- Real-time alerts and notifications when air pollution exceeds the threshold.
- Ability to remotely access real-time air quality data.
- Health hazards indication.

SENSOR NODE FLOW CHART

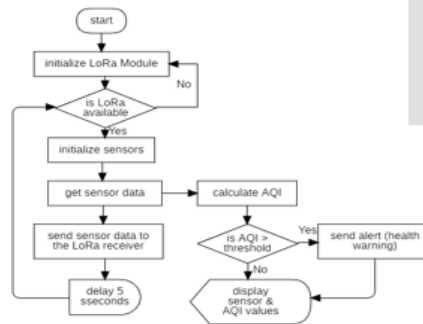

SYSTEM ARCHITECTURE FRAMEWORK

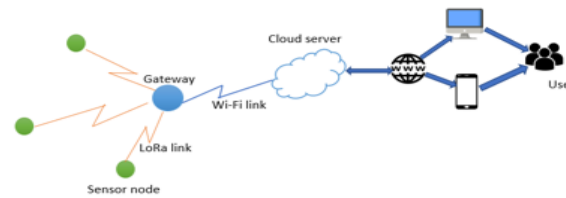

SENSOR NODE MODULE



The architecture of this system is mainly divided into two parts: a sensor node or LoRa node, and a gateway node or LoRaWAN gateway. The overall system architecture consists of mainly four parts: (i) several sensors used to sense and measure different air pollutants parameters, (ii) a LoRa network that consists of a LoRa shield in the sensor node and a gateway node, all of them are connected to the ATmega328 microcontroller as the main controller, (iii) Thingspeak cloud server for data storage, visualization, and integration, (iv) a user application system that consists of a web-based application that can be accessed via a computer or smartphones web-browsers.

DATA VISUALIZATIONS



CONCLUSION

The system has the potential to fulfill a significant requirement by monitoring the quality of the air that residents and miners breathe in, which is characterized by higher levels of pollutants that have an impact on a large number of people. People are made aware of potentially hazardous amounts of these detected contaminants as a means of providing an indicator of potential health hazards.

FUTURE DIRECTIONS

The goals set forth at the outset of this study have been met with success. The goal of this project was to utilize LoRa technology and sensors to implement air quality monitoring and also to raise people's awareness of air quality by enhancing data accessibility. However, more studies are required. To improve data accuracy, researchers may deploy more sensors while developing other AQMS. New performance measures can be performed to improve analytic findings from a methodological standpoint. Another prospective area of research is the influence of AQMS on healthcare, particularly during pandemics, especially in areas with population and mining activities. A prediction approach may also be used to forecast the future AQI based on the data gathered over a certain period. A sufficient number of synthesized nodes may be deployed as a LoRa network allowing users access to considerably more information.

Appendix 2: Part of the Source Code

```
#include <MapleFreeRTOS821.h>

#include <LCD_I2C.h>

#define mySerial Serial3

#include <LoRa_STM32.h>

#include <ArduinoJson.h>

#include <RTClock.h>

RTClock rtclock (RTCSEL_LSE); // initialise

int timezone = 3;    // change to your timezone

time_t tt, tt1;

tm_t mtt;

int globAlmCount = 0;

int lastGlobAlmCount;

int SPECAlmCount = 0;

int lastSPECAlmCount;

int alarmcount = 3;

uint8_t AlarmExchange = 0;

bool dispflag = true;

const char * weekdays[] = {"Mon", "Tue", "Wed", "Thu", "Fri", "Sat", "Sun"};

const char * months[] = {"Dummy", "Jan", "Feb", "Mar", "Apr", "May", "Jun", "Jul", "Aug",
"Sep", "Oct", "Nov", "Dec" };

uint8_t str2month(const char * d)

{

    uint8_t i = 13;
```

```

while ( (--i) && strcmp(months[i], d) != 0 );

return i;

}

const char * delim = " :";

char s[128]; // for sprintf

char s1[50];

long double tm = 0, time_disp = 0, transmit_time = 0 ;

boolean serial_dt = false;

#include <SPI.h>

#include <SD.h>

#define sd_cs PB1

#define lora_cs PA4

#define rst 14

#define dio0 PA1

File myFile;

int Timeout = 50;

long t = 0;

long count = 0, AQI;

String Recv_msg = "", date_time = "", node_id = "nd01", AQI_status;

char time_string[50];

float temp = 0, hum = 0, ppmNO2 = 0, pm25 = 0, pm10 = 0, ppmCo = 0, ppmCo2 = 0, ppmSO2
= 0;

LCD_I2C lcd(0x27, 20, 4);

void setup()

{

```

```

delay (500);

Serial.begin(9600);

mySerial.begin(9600);

LoRa.setPins(lora_cs, rst, dio0);

lcd.begin();

lcd.backlight();

lcd_print(0, 0, " checking SD card");

Serial.print("Initializing SD card...");

// pinMode(sd_cs, OUTPUT);

// pinMode(lora_cs, OUTPUT);

// digitalWrite(lora_cs, HIGH);

// digitalWrite(sd_cs, LOW);

if (!SD.begin(PB1)) {

    Serial.println("sd card error!");

    lcd_print(0, 1, " SD card error ");

    while (1);

}

//digitalWrite(sd_cs, HIGH);

Serial.println("SD card ok");

lcd_print(0, 1, " SD card ok ");

// digitalWrite(lora_cs, LOW);

if (!LoRa.begin(433E6)) { //initialize lora module

    Serial.println("Starting LoRa failed!");

    lcd_print(0, 2, "LoRa failed!");

```

```
    lcd_print(0, 3, " Restart System ");  
    while (1);  
}  
  
//digitalWrite(lora_cs, HIGH);  
  
delay (2000);  
  
start_time();  
  
mySerial.setTimeout(Timeout);  
  
    lcd.clear();  
  
    lcd_print(0, 1, " Please wait...");  
  
    delay (4000);  
  
    date_time = get_time();  
  
    set_tasks();  
  
}  
  
void loop()  
  
{  
  
    //Serial_task();  
  
}
```

RESEARCH OUTPUTS

Poster Presentation Award

This work was presented during the 1st International Conference on Technological Advancement in Embedded and Mobile Systems (ICTA-EMOS) and also received the Best poster award.

