

2020-02

A column design for groundwater hardness removal using cashew nut shells activated carbon with potential application in low-income communities

Mwakobe, Emmanuel C.

NM-AIST

<https://doi.org/10.58694/20.500.12479/964>

Provided with love from The Nelson Mandela African Institution of Science and Technology

**A COLUMN DESIGN FOR GROUNDWATER HARDNESS REMOVAL
USING CASHEW NUT SHELLS ACTIVATED CARBON WITH
POTENTIAL APPLICATION IN LOW-INCOME COMMUNITIES**

Emmanuel C. Mwakabole

**A Dissertation Submitted in Partial Fulfilment of the Requirements for the Degree of
Master's in Hydrology and Water Resources Engineering of the Nelson Mandela African
Institution of Science and Technology**

Arusha, Tanzania

February, 2020

ABSTRACT

Water hardness has been associated with various human health problems. In many developing countries, groundwater is the main source of drinking water. Water hardness has a significant impact on groundwater quality, especially in arid and semi-arid regions, leading to wasted financial investments in borehole drilling and worsening community accessibility to potable water. In this study, relatively cheap and readily available raw materials were used to remove total hardness from groundwater in a laboratory scale column setting. In this study, design parameters for a filter to remove total hardness from groundwater were investigated. The optimal design parameters for the packed column were as follows: area (A) of 265.0 cm^2 and diameter (d) of 18.4 cm , at a flowrate (Q) of $75.0 \text{ cm}^3/\text{min}$. For the field hard water flowrate of $2.0 \text{ mL}/\text{min}$, the optimal empty bed contact time was 70.7 min whereas the breakthrough time was about 430 min . Also, for the field hard water, the results showed that competing ions from other contaminants in groundwater lowered the materials adsorption capacity. Results from this study indicated that Cashew-nut Shell Activated Carbon may be used to adequately remove total hardness from groundwater. Using these results, a pilot filter was designed. The designed water hardness filter may provide the much-needed solution to many potable water problems facing communities in most developing countries.

Keywords: Activated carbon; Cashew-nut shells; Column design; Groundwater; Hardness removal; Water filter

DECLARATION

I, Emmanuel C. Mwakaboledo hereby declare to the Senate of the Nelson Mandela African Institution of Science and Technology that this dissertation titled “A column design for groundwater hardness removal using cashew nut shells activated carbon with potential application in low-income communities” is my own original work and that it has neither been submitted for degree award in any other institution.

Emmanuel C. Mwakabole:
Name and signature of candidate
Date

The above declaration is confirmed

Prof. Karoli N. Njau:
Name and signature of supervisor 1.
Date

Dr. Mwemezi J. Rwiza:
Name and signature of supervisor 2.
Date

COPYRIGHT

This dissertation is copyright material protected under the Berne Convention, the Copyright Act of 1999 and other international and national enactments, in that behalf, on intellectual property. It must not be reproduced by any means, in full or in part, except for short extracts in fair dealing; for researcher private study, critical scholarly review or discourse with an acknowledgement, without the written permission of the office of Deputy Vice Chancellor for Academic, Research and Innovation on behalf of both the author and the Nelson Mandela African Institution of Science and Technology.

CERTIFICATION

The undersigned certify that, they have read and found that the dissertation conform to the standard and format acceptable for examination, therefore do hereby recommend for examination of dissertation entitled “A column design for groundwater hardness removal using cashew nut shells activated carbon with potential application in low-income communities”, in fulfilment of the requirements for the degree of Master of Science in Hydrology and Water Resources Engineering at Nelson Mandela African Institution of Science and Technology, Arusha, Tanzania.

Prof. Karoli N. Njau:

Name and signature of supervisor 1

Date

Dr. Mwemezi J. Rwiza:

Name and signature of supervisor 2

Date

ACKNOWLEDGEMENTS

Writing this thesis has been fascinating and extremely rewarding. I would like to pay my obeisance to GOD the almighty, to have bestowed upon me good health, courage, inspiration, zeal and the light.

This study was kindly supported by the Nelson Mandela African Institution of Science and Technology (NM-AIST) through financial support by the African Development Bank (AfDB). I am grateful to the Bank (AfDB) who made my study and stay in Arusha possible and complete my research work. This work would not have been possible without the financial support from the bank. I am also thankful to my employer The Dodoma Urban Water Supply and Sanitation Authority (DUWASA), for granting me a study leave to pursue this course at the NM-AIST.

I express my sincere and deepest gratitude to my supervisors; Prof. Karoli N. Njau and Dr. Mwemezi J. Rwiza both from the school of MEWES of the NM-AIST for their expertise, invaluable guidance, constant encouragement, affectionate attitude, understanding, patience and healthy criticism added considerably to my experience. Without their continual inspiration, it would have not been possible to complete this study. My appreciation also goes to the Ministry of Water staffs Ms. Sophia Mwenda and Mr. Samweli Sangalifor their companion during sample collection and experiments in Dodoma.

My acknowledgement would be incomplete without thanking the main source of my strength; my family and parents. They have always stood by my side and prayed for my health and successful completion of my studies. My lovely wife Neema, and children Mary, Derreck and Meghan have been strong and tolerant of my absence during my study.

DEDICATION

I dedicate this work to my late brother Christopher C. Mwakabole (1985-2008), may his soul continue to rest well.

I also dedicate this work to my lovely parents Charles M.Mwakabole and Mary E. Msuya who raised and nurtured me to who I am today. Also,this work is dedicated to my beloved wife Neema D. Tandila, children Mary E. Mwakabole,Derreck E. Mwakaboleand Meghan E. Mwakabolefor their encouragement and patience. This work is also dedicated to my relatives George, Godfrey, James, Daniel, Stephen and sister Eliena for their support in different circumstances and times during my studies.

TABLE OF CONTENTS

ABSTRACT	i
DECLARATION	ii
COPYRIGHT	iii
CERTIFICATION	iv
ACKNOWLEDGEMENTS	v
DEDICATION	vi
LIST OF TABLES	x
LIST OF FIGURES	xi
LIST OF ABBREVIATION AND SYMBOLS	xii
CHAPTER ONE	1
INTRODUCTION	1
1.1 General background	1
1.2 Problem statement	3
1.3 Rationale of the study	4
1.4 Objectives	5
1.4.1 General objective	5
1.4.2 Specific objectives	5
1.5 Research questions	5
1.6 Significance of the research	5
1.7 Delineation of the study	6
CHAPTER TWO	7
LITERATURE REVIEW	7
2.1 Water hardness	7
2.1.1 Classification of water hardness	7
2.1.2 Types of hardness	8
2.2 Water hardness in Tanzania	9
2.3 Methods for hardness removal	11
2.3.1 Membrane filtration (reverse osmosis)	12
2.3.2 Biosand filters	13
2.3.3 Ion exchange	13

2.3.4	Adsorption.....	13
2.4	Hardness removal by adsorption.....	15
2.4.1	Pumice stone as an adsorbent.....	16
2.4.2	<i>Moringa oleifera</i> as an adsorbent.....	16
2.4.3	Activated Carbon as an adsorbent.....	16
2.5	Water hardness removal by activated carbon.....	17
2.6	Adsorption isotherm models.....	18
2.6.1	Langmuir isotherm model.....	18
2.6.2	Freundlich isotherm model.....	19
2.7	Packed bed design.....	20
2.7.1	Axial dispersion.....	21
2.8	Design methods.....	21
2.8.1	The kinetic method.....	22
2.8.2	Scale-up method.....	24
2.9	Contribution of this study to the body of knowledge.....	24
CHAPTER THREE.....		26
MATERIALS AND METHODS.....		26
3.1	Study location.....	26
3.2	Materials.....	27
3.2.1	Adsorbates.....	27
3.2.2	Adsorbent.....	27
3.3	Methods.....	29
3.3.1	Characterization of field groundwater.....	29
3.3.2	Production of an activated carbon.....	29
3.4	Experiments.....	29
CHAPTER FOUR.....		32
RESULTS AND DISCUSSION.....		32
4.1	Breakthrough point.....	32
4.1.1	Effect of synthetic hard water flowrate on breakthrough time.....	32
4.1.2	Effect of field hard water flowrate on breakthrough time.....	33
4.1.3	Hardness removal capacity vs. time.....	35
4.2	Pilot column design.....	38

CHAPTER FIVE	41
CONCLUSION AND RECOMMENDATIONS	41
5.1 Conclusion.....	41
5.2 Recommendations	42
REFERENCES	43
RESEARCH OUTPUT.....	51

LIST OF TABLES

- Table 1. Classification used for water hardness.
- Table 2. Types of hardness.
- Table 3. Hardness concentration of different boreholes in Dodoma.
- Table 4. Comparison of physical and chemical adsorption.
- Table 5. Isotherm equations.
- Table 6. Parameters recorded from field hard water column experiment
- Table 7. Column design parameters for optimization
- Table 8. Breakthrough time vs. influent concentration gradient and flowrate
- Table 9. A summary of filtration system design parameters

LIST OF FIGURES

- Figure 1. Hardness levels in borehole as compared to standards (WHO & TBS).
- Figure 2. Membrane filtration (reverse osmosis)
- Figure 3. Study/Sampling area
- Figure 4. Schematic diagram of the experimental setup for laboratory packed-bed column adsorption studies
- Figure 5. Effluent concentration versus time for synthetic hard water
- Figure 6. Effluent concentration versus time for field hard water
- Figure 7. Variation in sorption capacity of GCNSAC from synthetic hard water
- Figure 8. Variation in sorption capacity of GCNSAC from field hard water

LIST OF ABBREVIATION AND SYMBOLS

AfDB	The African Development Bank
AWWA	American Water Works Association
CDI	Capacitive De-Ionization
DBP	Disinfection by Products
DUWASA	Dodoma Urban Water Supply and Sanitation Authority
EBCT	Empty Bed Contact Time
EWURA	Energy and Water Utilities Regulatory Authority
FR	Filtration Rate
GAC	Granular Activated Carbon
GCNSAC	Granular Cashew Nut Shell Activated Carbon
GPS	Global Positioning System
MoWI	Ministry of Water and Irrigation
NBS	National Bureau of Statistics
NM-AIST	The Nelson Mandela African Institution of Science and Technology
PAC	Powdered Activated Carbon
POU	Point of Use
SDG	Sustainable Development Goals
SOC	Synthetic Organic Chemicals
TBS	Tanzania Bureau of Standards

WHO

World Health Organization

CHAPTER ONE

INTRODUCTION

1.1 General background

Accessibility to adequate and potable water for all is among the key goals of the World Health Organization (WHO) and Sustainable Development Goals (SDGs)(UNGA, 2015; WHO, 2008). It is approximated that 1.1 billion people around the world do not have access to potable water. A large proportion of this population is from the rural and peri-urban areas of developing countries(Cassivi, Johnston, Waygood, &Dorea, 2018; WHO, 2017). The use of unsafe water contributes to about 80% of water-related diseases and kills around 10 million people annually (Baumgartner, Murcott, & Ezzati, 2007; Momba, Obi, & Thompson, 2009; Murcott, 2006; Pritchard, Mkandawire, Edmondson, O’neill, & Kululanga, 2009).

Poor access to potable water is attributable to lack of affordable techniques for water treatment, lack of expertise in water supply operation and maintenance as well as the lack of skills in water quality improvement. This, coupled with the prevalence of geological and anthropogenic contaminant levels, may lead to contamination of rural water supply systems and expose the rural communities to waterborne disease risks (Mackintosh & Colvin, 2003; Mwabi *et al.*, 2011).

In areas with limited surface water resources, communities depend largely on groundwater. For example, in rural areas of Tanzania, where this study was conducted, 25% of the population depends on groundwater as their sole source of drinking water(Elisante & Muzuka, 2017). Furthermore, in the central and coastal areas of Tanzania, groundwater is reported to be highly contaminated with hardness-causing ions, making the water unsuitable for domestic use (Hiji & Ntalikwa, 2014a). A total of 43 boreholes in Dodoma, Tanzania, have been recorded to have total hardness concentration levels well above the maximum allowable (Table 3 and Fig. 1). Ions that contribute to water hardness are mainly Ca^{2+} and Mg^{2+} . When present in very high levels, these ions cause a salty taste in water (Meena, Gunsaria, Meena, Kumar, & Meena, 2011). Magnesium and Calcium rich sedimentary rocks are the main sources of water hardness in groundwater systems of Tanzania (Napacho & Manyele, 2010).

The levels of Ca and Mg salts in some parts of Tanzania have been reported to be as high as 1300 mg/L CaCO₃. The Tanzanian Bureau of Standards (TBS) and WHO recommended level of hardness in water are 600 mg/L and 500 mg/L, respectively (TBS, 2014; WHO, 2008). Thus, the salt burden in these water sources is costly and leads to abandonment of boreholes with high hardness concentration and where there are piped systems, it damages water supply infrastructure and affects both human and ecosystem health. Infrastructure damages caused by water hardness include clogging of water pipes, sinks and other appurtenances (Seo *et al.*, 2010). Health issues related to high levels of Ca²⁺ and Mg²⁺ in water include skin diseases, hair loss, eczema and kidney stones (Johnson, 2015; Meena *et al.*, 2011; WHO, 2011).

A number of conventional hardness removal methods have been developed. These include, but are not limited to, membrane filtration, ion exchange, and electro-based techniques (Saeed & Hamzah, 2013). However, in most developing countries such as Tanzania, high installation, operation, and maintenance costs hinder the applicability of these techniques.

Adsorption of contaminants onto activated carbons has increasingly become the industrial standard when it comes to ionic decontamination of aqueous solutions. Adsorption is a process of enriching chemical species from a fluid phase onto solids. It is an efficient removal of a variety of solutes in water. Usually, molecules or ions are removed from the aqueous solution by adsorption onto a solid surface known as an adsorbent (Crittenden & Thomas, 1998).

Adsorption using activated carbons made from agro-wastes has been proven to be efficient in water and wastewater treatment (Rwiza, Oh, Kim, & Kim, 2018). Cashew nut shells, which are among the abundant agro-wastes, are usually disposed of after extraction of the endosperm. When converted into activated carbons, the once-waste cashew nut shells can be used to reduce the levels of ionic contaminants in groundwater, hence softening the once-hard water. The average annual production of cashews in Tanzania stands at 300000 tons, and this is expected to increase due to the government revitalized attention to the crop.

Water softening by cashew nut shell activated carbon has been reported to have 90% efficiency in the softening of hard water in batch tests (Rolence, Machunda, & Njau, 2014). Activated carbons from cashew nut shells have high carbon content and possess great adsorption capacity mainly due to their porosity (Otero, Rozada, Calvo, Garcia, & Moran, 2003). Although batch

laboratory studies provide useful information on the use of cashew nut shell activated carbon-based adsorbents for removal of specific constituents in water, continuous column studies give the most realistic application of the processes involved in water treatment. This is attributable to the higher adsorption abilities in equilibrium with the influent concentration rather than the effluent concentration (Eckenfelder, 1989).

In many rural areas in developing countries, functioning centralized water treatment systems are inexistent. In such places of the world, the point of use (POU) treatment systems are inevitable (Mintz, Bartram, Lochery, & Wegelin, 2001). However, most of the available POU's on the market target contaminants such as heavy metal ions, micro bacteria and do not treat the taste of drinking water by reducing its saltiness. There are no devices on the market that specifically target water hardness.

Therefore, this study aims at examining the fixed-bed adsorption column of water hardness by granular cashew nut shells activated carbon (GCNSAC) which will form the basis of the design of a full-scale water filtration system that removes hardness from groundwater. A successful full-scale water filtration system using these low-cost adsorbents would provide a viable solution to increase access to potable water in developing countries.

1.2 Problem statement

Availability of sustainable water supply in arid and semi-arid regions across the globe has been a challenge. In Tanzania, the central part of the country has been lacking adequate access to potable water. Kongwa district in Dodoma, is among many in the region affected with accessibility of potable water hence it has low hours of service as it stands at 3 hours per day (EWURA, 2015/2016). Currently, most of the available groundwater sources are not useful due to high levels of hardness. A study conducted by the Ministry of Water and Irrigation (MoWI) (2015), indicated that a minimum hardness recorded at Iduoborehole No. 02 was 810 mg/L as CaCO₃, and maximum at Mnyakongoborehole No. 01 was 1300 mg/L (MoWI, 2015). It was recorded in September, 2018 that, another borehole in Kongwa had hardness of 2172 mg/L as CaCO₃. Reported high levels of hardness in the area, have resulted in abandonment of boreholes and associated infrastructures (MoWI, 2015). This calls upon an immediate need for hardness removal technology.

Available techniques for hardness removal such as ion exchange, electro dialysis, and membrane processes (El-Sayed, 2010) are reported to have high operation and maintenance costs as well as installation costs (Pandey, Sharma, & Sambhi, 2010). This calls for the search of a cost-effective way to soften hard water.

Adsorption technology has recently become an industries promising way for water treatment (Saeed & Hamzah, 2013). Adsorption is a phase transfer process that is commonly used in practice to remove substances from fluid phases (Worch, 2012). In water treatment, adsorption has been proved as an efficient removal process for an array of solutes. In adsorption, molecules or ions (adsorbates) are removed from the aqueous solution by adsorption onto a solid surface known as adsorbent (Worch, 2012). Adsorption is mainly performed in two approaches, the batch processes and fixed bed processes (Crittenden & Thomas, 1998).

1.3 Rationale of the study

In batch scale, removal of hardness causing ions using agricultural products and byproducts such as *Moringa oleifera*, peanut hull, and cashew nut shells as adsorbents has been reported to be cheap in softening hard water (El-Sayed, 2010; Fahmi, Nor Wahidatul Azura, Pang, & Nasrul, 2011; Rolence *et al.*, 2014).

However, facilities for treating groundwater from excessive hardness so as to render it palatable are limited in developing countries, particularly in rural and peri-urban areas. It has not been reported so far of an attempt to remove hardness causing ions by adsorption technique in fixed bed adsorbents.

Therefore, the proposed study aims at developing a water filter by using activated carbon synthesized from locally available materials (cashew nut shells) as filtering media for water hardness removal to acceptable standards.

1.4 Objectives

1.4.1 General objective

To develop a water filter for the removal of total hardness from ground water to acceptable levels as set by the WHO and/or TBS.

1.4.2 Specific objectives

- (i) To establish groundwater characteristics from selected borehole in Kongwa.
- (ii) To produce an activated carbon from cashew nut shells and test its properties
- (iii) To design and test a lab scale filter for hardness removal and optimize operation parameters.
- (iv) To design a pilot column filter by using lab scale filter parameters

1.5 Research questions

- (i) What are the characteristics of Kongwa groundwater sources?
- (ii) What are the properties of activated carbon from Cashew-nut shells?
- (iii) What will be the efficiency of the filter in hardness removal? And in the presence of other constituents what will be the response of the filter media?
- (iv) What are the design parameters (diameter, flow rate and optimum contact time) to be used in the pilot column?

1.6 Significance of the research

This study will generate information on the applicability of a water filter that uses cashewnut shell activated carbon as filtering media for hard water obtained from selected boreholes in Kongwa and similar areas. The findings shall form the basis for producing more water filters for water softening at both community and household level. The abundance of these agricultural products enhances the implementation of this project with the potential to be scaled up.

1.7 Delineation of the study

Hardness in water, is mainly found in arid and semi-arid regions in Tanzania. It was noted that, among seven districts in Dodoma, Kongwa recorded a borehole with highest concentration values of total hardness. Thus, the water sample was collected in Kongwa – Sejeli ward. This study focused on the total hardness (as CaCO_3) of water among water quality parameters monitored from water sources. This aesthetic parameter in water quality if not maintained within the recommended levels (TBS – 600mg/L and WHO – 500mg/L) renders such water unpalatable. The effect of granular cashew-nut shell activated carbon on other water quality parameters was not covered in this scope. The study noted the reduction in saturation time of adsorbents for the groundwater from Kongwa borehole as compared to the synthesized hard water from the laboratory.

CHAPTER TWO

LITERATURE REVIEW

2.1 Water hardness

Water hardness is the traditional measure of the capacity of water to react with soap, hard water requires considerably more soap to produce lather (WHO, 2011). Hard water often produces a noticeable deposit of precipitate (e.g. insoluble metals, soaps or salts) in containers, including “bathtub ring”. It is not caused by a single substance but by a variety of dissolved polyvalent metallic ions, predominantly calcium and magnesium cations, although other cations (e.g. Al^{3+} , Ba^{2+} , Fe^{2+} , Mn^{2+} , Sn^{2+} and Zn^{2+}) also contribute. Hardness is most commonly expressed as milligrams of calcium carbonate equivalent per litre (WHO, 2011).

2.1.1 Classification of water hardness

Water can be classified into two groups as soft and hard water depending on the amount of calcium and magnesium contents in it. The water hardness measured as parts per million of calcium carbonate spans the following ranges of groups as shown in Table 1.

Table 1: Classifications of water hardness

Classification A		Classification B	
Concentration (mg/L)	Degree of hardness	Concentration (mg/L)	Degree of hardness
0-50	Soft Water	0-75	Soft
50-100	Moderate Soft Water	75-150	Moderately hard
100-150	Slightly Hard Water	150-300	Hard
150- 250	Moderately Hard	300+	Very hard
250 -350	Hard Water		
> 350	Excessively Hard Water		

Source: Gray (2008)

2.1.2 Types of hardness

The hardness of water has been generally known to be caused by a variety of divalent cations. These cations have a tendency to combine with anions (negatively charged ions) in the water to form stable salts. As can be seen in Table 2, the type of anion found in these salts has therefore been used to distinguish between the two types of hardness; carbonate and non-carbonate hardness (Hiji & Ntalikwa, 2014b).

Table 2: Types of hardness

Carbonate hardness compounds (temporary hardness)	Non-carbonate hardness compounds (permanent hardness)
Calcium carbonate (CaCO ₃)	Calcium sulfate (CaSO ₄)
Magnesium carbonate (MgCO ₃)	Magnesium sulfate (MgSO ₄)
Magnesium bicarbonate (Mg(HCO ₃) ₂)	Calcium chloride (CaCl ₂)
Magnesium hydroxide (Mg(OH) ₂)	Magnesium chloride (MgCl ₂)
Calcium hydroxide (Ca(OH) ₂)	

Source: Mihayo and Mkoma (2012) and Van der Aa (2003)

Table 2 shows that, carbonate hardness is caused mainly by Ca²⁺ and Mg²⁺ combined with anion (CO₃²⁻ or HCO₃³⁻ or OH⁻) to form a salt. In contrast, non-carbonate hardness forms when Ca²⁺ and Mg²⁺ combine with anything other than carbonate, bicarbonate, and hydroxide ions. Carbonate hardness is sometimes called temporary hardness because it can be removed by boiling the water. As it can be seen in equation 2.1, the heating of water results to decomposition of salt into metal oxide, carbon dioxide and water, hence removing the hardness (Hiji & Ntalikwa, 2014b).

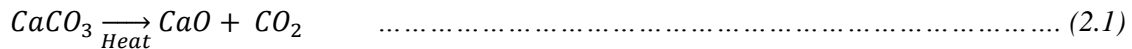

Non-carbonate hardness cannot be broken down by boiling the water, so it is also known as permanent hardness. In general, it is important to distinguish between the two types of hardness because the removal methods differ significantly. When measuring hardness, it is typically considered the total hardness which is the sum of all hardness compounds in water, expressed as calcium carbonate equivalent.

Total hardness includes both temporary and permanent hardness caused by calcium and magnesium compounds.

$$\text{Total Hardness} = \text{Carbonate hardness} + \text{Non carbonate hardness} \dots\dots\dots (2.2)$$

2.2 Water hardness in Tanzania

Numerous studies have been conducted on prevalence of hardness problem in Tanzania. A study by Napacho and Manyele (2010) reported the prevalence of water hardness in Temeke district, Dar es Salaam. Most of the results show compliance with TBS and WHO standards only few samples drawn from Kibonde Maji-Kwa Numbwa (710 mg/L) and MjiMwema (540 mg/L) deviates from WHO and TBS standards respectively. A previous study done in Dodoma municipality revealed high levels of water hardness and found that, the concentration of calcium at all study sites was higher than the maximum allowable value of 100 mg/L (Hiji & Ntalikwa, 2014b).

In Kingolwira Village of Morogoro region, Tanzania, a study by Shayo, Chove, Gidamis, and Ngoma (2007) revealed that, the three sites had total hardness of water ranging from 19.6 to 281.10 mg/L as CaCO_3 . According to WHO and TBS standards, the results obtained are lower than the recommended values indicating that water from these three sites is soft.

Moreover, a study conducted in 2015 by the Ministry of water in Tanzania, revealed that a total of 42 boreholes in Dodoma region, has hardness concentrations beyond the Tanzanian standard of 600 mg/L (TBS, 2014). This has been illustrated in Table 3 and Fig. 1.

Table 3: Hardness concentration of different borehole waters in Dodoma

B/H.No.	District	Hardness (mg/L)	B/H. No.	District	Hardness (mg/L)
1	Bahi	701	11	Chamwino	698
2	Bahi	840	12	Chamwino	698
3	Bahi	862	13	Chamwino	808
4	Bahi	740	14	Chamwino	808
5	Bahi	868	15	Chamwino	840
6	Bahi	638	16	Chamwino	840
7	Bahi	894	17	Chamwino	624
8	Dodoma CC	750	18	Chamwino	624
9	Dodoma CC	1240			
10	Dodoma CC	835			
B/H.No.	District	Hardness (mg/L)	B/H. No.	District	Hardness (mg/L)
19	Kongwa	1200	29	Mpwapwa	726
20	Kongwa	1300	30	Mpwapwa	710
21	Kongwa	912	31	Mpwapwa	792
22	Kongwa	2172.5	32	Mpwapwa	1504
23	Kongwa	810	33	Mpwapwa	1037
24	Kongwa	1092	34	Mpwapwa	698
25	Kongwa	640	35	Mpwapwa	940
26	Kongwa	700	36	Mpwapwa	720
27	Kongwa	1020	37	Mpwapwa	1000
28	Kongwa	1030	38	Mpwapwa	670
			39	Mpwapwa	660
			40	Mpwapwa	848
			41	Mpwapwa	910
			42	Mpwapwa	908

Source: MoWI (2015)

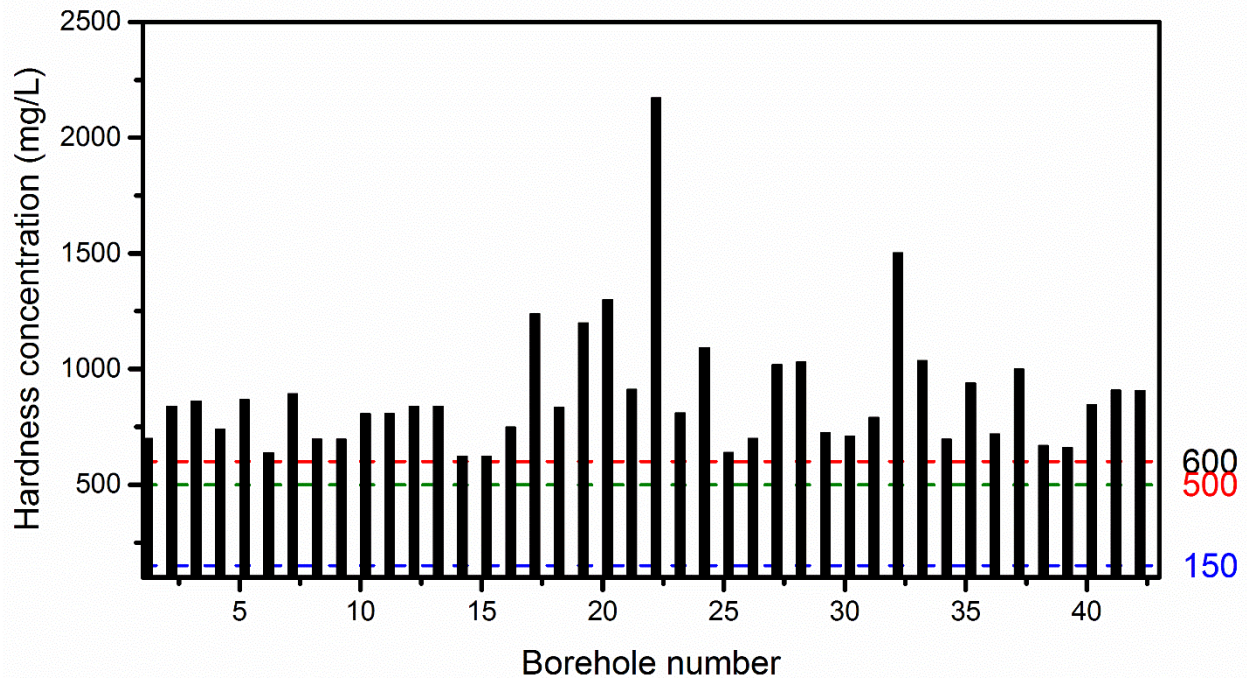

Figure 1: Hardness levels in boreholes as compared to standards set by WHO, TBS and Corbitt (Corbitt, 1990; TBS, 2014; WHO, 2008)

2.3 Methods for hardness removal

Potable water has to meet standards set for water quality. Hardness from water has to be controlled and removed to recommended standards (TBS and WHO). Various methods for hardness removal have been discovered and are currently in use. Methods such as boiling (temporary hardness removal), ion exchange, electrodialysis, and membrane processes such as reverse osmosis are existing (El-Sayed, 2010).

The degree of hardness in water is important for aesthetic acceptability by consumers and for economic and operational considerations. Hard waters are softened for those reasons using several applicable techniques, and the mineral compositions are significantly removed. The choice of the most appropriate softening technology depends largely on affordability of the technology and local circumstances.

2.3.1 Membrane filtration (reverse osmosis)

Membrane filtration is a pressure driven process in which membrane acts as a selective barrier to restrict the passage of pollutants such as organics, nutrients, turbidity, microorganisms, inorganic metal ions and other oxygen depleting pollutants, and allows relatively clear water to pass through (Mulder, 2012). With technological advances and the ever increasing stringency of water quality criteria, membrane processes are becoming a more attractive solution to the challenge of quality water, and water reuse (Shannon *et al.*, 2008). However, the technique which requires regular replacement of membranes and backwashing cannot be utilized in rural areas particularly in developing countries due to its complexity in operation and capital costs of the systems. In reverse osmosis Fig. 2, pressure is applied to the concentrated solution reversing the natural direction of flow, forcing water across the membrane from the concentrated solution into the more dilute solution.

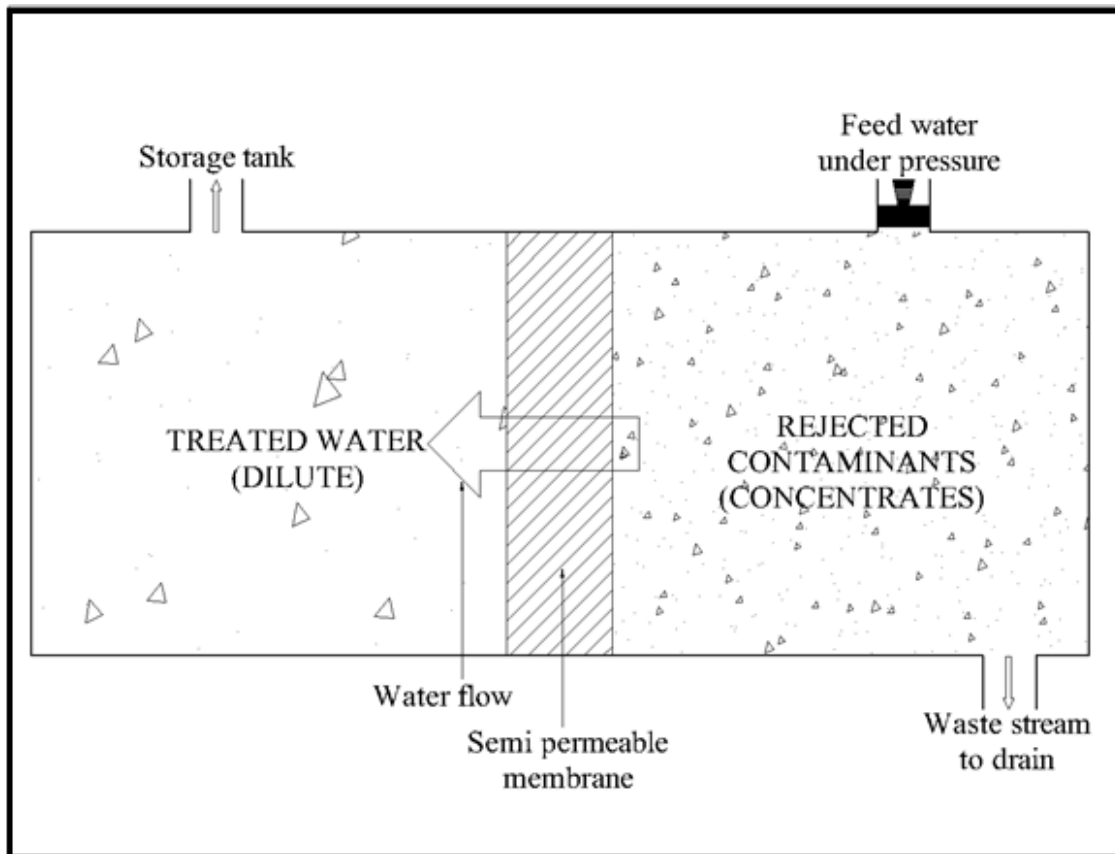

Figure 2: Reverse osmosis

2.3.2 Biosand filters

Biosand filters work in the same manner as the large scale slow sand filter system which have been used in municipal water treatment for more than 150 years (Taras & Association, 1981). They are most applicable in pathogens removal as well as turbidity removal and not hardness (CAWST, 2009), hence cannot fit for water hardness removal.

2.3.3 Ion exchange

This technique involves the exchange of calcium and magnesium ions in water for sodium ions when hard water flows through a resin containing sodium ions. Consequently water leaving the resin has sodium ions in place of calcium and magnesium ions (Manahan, 2011). This process raises following concerns with regard to the remained water quality; first, excess sodium ions are introduced in water that may lead to health problems for people who are not required to take salts (Frankel, 2011), second, the method requires careful operation as it tends to remove all calcium and magnesium ions from water if operated inefficiently (Skipton, Dvorak, & Niemeyer, 2008).

Currently there is no recorded information on the application of ion exchange in hard water softening in Tanzania. However, in Tanzania, sophisticated hardness removal techniques have been commercialized and applied by companies at industrial level. Few companies are currently importing filters of different types for different uses at industry and household levels most of which are for pathogens removal and will leave the salty taste of water as it is (Merrywater, 2017; NABAKI, 2017).

2.3.4 Adsorption

Adsorption is the treatment method in which dissolved constituents (solutes) are removed from water by transferring them to the surface of a solid (Howe, Crittenden, Hand, Trussell, & Tchobanoglous, 2012). The method is commonly used in municipal drinking water treatment to remove synthetic organic chemicals (SOCs), taste and odor causing organics, color-forming organics, and disinfection-by-product (DBP) precursors.

(i) Physical adsorption (physisorption):

In physisorption, adsorption is induced by the van der Waals forces. Physisorption is independent of the electronic properties of the adsorbate and adsorbent molecules. There is no electrons exchange in physisorption. The targeted molecules/ions (adsorbates) are attached to the surface (adsorbent) by relatively weak van der Waals forces. In physisorption, multiple layers may be formed which have similar heats of adsorption. Physical adsorption is predominant at temperatures below 150°C, and is characterized by a relatively low adsorption energy at most a few kcal/mol. The adsorbate is less strongly attached to a specific site in physisorption compared to chemical adsorption (Poulopoulos & Inglezakis, 2006).

(ii) Chemical adsorption (chemisorption):

In chemisorption, adsorbates chemically interact with adsorbents. This involves an exchange of electrons between surface sites and adsorbate molecules, forming a chemical bond. Chemically adsorbed adsorbates are firmly attached to the adsorbent surfaces such that, they cannot freely move within the interface. Chemisorption is predominantly more in higher temperatures compared to the physisorption because chemical reactions rapidly occurs in high temperatures (Poulopoulos & Inglezakis, 2006; Weber & Borchardt, 1972). Table 4 shows the comparison between chemical and physical adsorption processes.

Table 4: Comparison of physical and chemical adsorption

	Physisorption	Chemisorption
Coverage	Mono or multilayer	Mono layer
Nature of adsorption	Non-dissociative and reversible	Often dissociative, may be irreversible
Specificity to adsorption sites	Nonspecific	Very specific
Temperature range	Near or below the condensation point of the gas	Unlimited
Temperature dependence of uptake (with increasing T)	Decreases	Increases
Adsorption enthalpy	5 – 40 kJ/mol	40 – 800 kJ/mol
Kinetics of adsorption	Fast	Very variable, often slow
Desorption	Easy by reduced pressure or increased temperature	Difficult – high temperature is required to break bonds
Desorbed species	Adsorbate unchanged	Adsorbate may change

Source:Çeçen and Aktas (2011)

2.4 Hardness removal by adsorption

Adsorption has become among the most potential technique in treating water hardness (Saeed & Hamzah, 2013). Its design is simple and uses locally available materials/wastes as biosorbents (Gayatri & Ahmaruzzaman, 2010). In its application, the method has less sludge production and in most cases it is chemical free (Saeed & Hamzah, 2013).

Biosorbents materials which have been recently tested for hardness removal include; pumice stones, *Moringa Oleiferaseeds* (Muyibi & Evison, 1996) and peanut hull (Idris, Iyaka, Dauda, Ndamitso, & Umar, 2012). Also, it is reported that, the most common adsorbent material in drinking water treatment is activated carbon, which can be used in either granular (packed bed applications) or powdered (batch application) form (Howe *et al.*, 2012).

2.4.1 Pumice stone as an adsorbent

Pumice is derived from volcanic rocks when highly pressurized and super-heated rock is vigorously erupted from volcano (Sepehr, Sivasankar, Zarrabi, & Kumar, 2013). In the same study, it was found that natural pumice stone can remove about 80% and 50% calcium and magnesium ions respectively. Further, it was found out that, modified alkali pumice stone at optimum adsorption conditions, can remove 95% and 78% calcium and magnesium ions respectively. This shows that, pumice stone is good in removal of calcium ions than magnesium from hard water.

2.4.2 *Moringa oleifera* as an adsorbent

Moringa have been reported to be selective in a manner that calcium ions is favoured more than magnesium ions (Muyibi & Evison, 1996). Fahmi *et al.* (2011) observed that, hardness decreases with the increase of Moringa Oleifera dose. Additionally, it was reported that lower dosage of Moringa (20-30 mg/L) removes hardness by less than 50%. High turbid water has been reported to affect the removal efficiency of Moringa (Fahmi *et al.*, 2011). Thus, pre-treatment is required to achieve optimum adsorption. However, Moringa Oleifera tends to decomposed when in contact with water giving out unpleasant odor, which is objectionable to water users.

2.4.3 Activated Carbon as an Adsorbent

Activated carbons are unique and versatile adsorbents, they are used extensively to remove undesirable odour, colour, taste, and other organic and inorganic impurities. Their high adsorption capacity are due to high surface area they have, a microporous structure, and a high degree of surface reactivity (Bansal & Goyal, 2005). Activated carbon in water treatment use, dates back to the late 1920, where substances responsible for odour and taste were removed (Hendricks, 2006; Rittmann & McCarty, 2012).

Activated carbon has a high adsorptive surface area (500–1500 m²/g), while the pore volume ranges between 0.7 and 1.8 cm³/g. It is mainly used in the form of powdered activated carbon (PAC) in batch processes and/or granular activated carbon (GAC) in packed bed processes (Çeçen & Aktas, 2011).

(i) Powdered activated carbon (PAC)

Powdered activated carbon is made up of crushed and ground carbon particles such that 95–100% of it will pass through a designated sieve of 0.297 mm according to the American Water Works Association (AWWA) Standard, or 0.177 mm according to ASTM D5158 (Poulopoulos & Inglezakis, 2006). The average particle size of PAC is in the range of 15–25 μm . Powdered Activated Carbon is widely used in both water and waste water treatment, and it is difficult to regenerate due to colloidal particles which have to be separated from water before regeneration (Suzuki & Suzuki, 1990).

(ii) Granular activated carbon (GAC)

Granular activated carbon is commonly made in the form of crushed granules. Granular activated carbon has particles sizes ranging from 0.2 to 5 mm. Granular activated carbon is designated by mesh sizes such as 8/20, 20/40, or 8/30 for liquid phase adsorption. Particle sizes in the range of 12/42 mesh are advantageous for liquid phase adsorption (Suzuki & Suzuki, 1990).

Granular activated carbon is normally used in filters, in the purification processes for drinking water, groundwater and wastewater as an advanced treatment step. In some GAC applications in drinking water and wastewater treatment, a microbiological film can form on the particles. Thereby, biological removal of pollutants is combined with GAC adsorption (Poulopoulos & Inglezakis, 2006).

2.5 Water hardness removal by activated carbon

The study by Rolence *et al.* (2014) shows the performance of activated carbon as filtering medium in a number of conditions. The effects of pH, contact time, temperature and adsorbent dosage were investigated by using batch adsorption experiments. In this study, synthetic hardwater with hardness of 1214.8 mg/L as CaCO_3 was prepared and field water with hardness of 368 mg/L was collected from Kimani well located in Kisarawe district, Coast region, Tanzania

Results from coconut shell activated carbon revealed that, the removal efficiency at nearly neutral pH was 44%. However, maximum removal was observed at pH 12 which shall need post

treatment of the treated water to bring pH back to neutral mark for health reasons. Extra costs will be incurred to purchase chemicals for adjustment of the pH which renders an uneconomical approach to communities (El-Sayed, 2010; Rolence *et al.*, 2014).

On the other hand, results from cashewnut shells show that, the removal efficiency also varied depending on same conditions (pH, contact time, temperature and adsorption dose). Efficiency recorded was 94% and adsorption capacity was found to be 384 mg/g. The study by Rolence *et al.* (2014) reveals the potential of cashewnut shells for water softening.

Comparing the two materials, cashew nut shells seem to be more suitable due to the following reasons; quick in softening (30 minutes), less dosage (0.02 g/cm³), high adsorptive capacity (384 mg/g) and it's cheaply produced and available locally. Coconut shells takes longer to adsorb significant amount of hardness ions (4 hours), its adsorptive capacity is very low (3.25 mg/g). Rolence *et al.* (2014) recommended that, further studies should be conducted on optimization of cashewnut and coconut shells activation procedures as well as characterization of surface area of the materials to determine how much surface area is gained after the production of coconut and cashewnut activated carbons.

The study by Rolence *et al.* (2014) forms the basis of this study which is the design of a water filter for water softening at both domestic and community level by using activated carbon as filtering medium. Likewise, the level of water hardness of the field water used by Rolence *et al.* (2014) was very low as compared to the recorded levels at Iduo and Mnyakongo boreholes. Column tests will be carried out and a pilot filter developed.

2.6 Adsorption isotherm models

Adsorption isotherm models are developed to study the adsorption capacity of the adsorbent material and adsorption mechanism. Two models mostly used are; Langmuir adsorption isotherm and Freundlich adsorption isotherm.

2.6.1 Langmuir isotherm model

Langmuir adsorption isotherm which was originally developed to describe gas–solid-phase adsorption onto activated carbon, has traditionally been used to quantify and contrast the performance of different bio-sorbents (Langmuir, 1916). In its formulation, this empirical model

assumes monolayer adsorption (the adsorbed layer is one molecule in thickness). Adsorption can only occur at a finite (fixed) number of definite localized sites that are identical and equivalent, without lateral interaction and steric hindrance between the adsorbed molecules, even on adjacent sites (Vijayaraghavan, Padmesh, Palanivelu, & Velan, 2006).

2.6.2 Freundlich isotherm model

Freundlich isotherm (Freundlich, 1906) is the earliest known relationship describing the non-ideal and reversible adsorption, not restricted to the formation of monolayer. This empirical model can be applied to multilayer adsorption, with non-uniform distribution of adsorption heat and affinities over the heterogeneous surface (Adamson & Gast, 1967). In this perspective, the amount adsorbed is the summation of adsorption on all sites (each having bond energy), with the stronger binding sites are occupied first, until adsorption energy are exponentially decreased upon the completion of adsorption process (Zeldowitsch, 1934). Table 5 shows the Langmuir and Freundlich equations used in isotherm studies.

Table 5: Isotherm equations

Isotherm	Non-Linear	Linear	Plot
Langmuir	$q_e = \frac{Q_o b c_e}{1 + b c_e}$	$\frac{c_e}{q_e} = \frac{1}{b Q_o} + \frac{c_e}{Q_o}$ $\frac{1}{q_e} = \frac{1}{Q_o} + 1/b Q_o c_e$	$\frac{c_e}{q_e} vs c_e$ $\frac{1}{q_e} vs \frac{1}{c_e}$
Freundlich	$q_e = K_f c_e^{1/n}$	$log q_e = log K_f + (1/n) log c_e$	$log q_e vs log c_e$

Source:(Freundlich, 1906; Langmuir, 1916)

Where:

q_e = Amount of adsorbate in the adsorbent at equilibrium (mgg⁻¹)

Q_o = Maximum monolayer coverage capacities (mgg⁻¹)

b = Langmuir isotherm constant

C_e = Equilibrium concentration (mgL⁻¹)

K_f = Freundlich isotherm constant (mgg⁻¹) related to adsorption capacity

2.7 Packed bed design

Majority of adsorption investigations were conducted in the batch mode, likewise the study on removal of hardness causing ions from water by cashew nut shells activated carbon was done in batch scale (Rolence *et al.*, 2014). Although batch studies provide important information on the applicability of adsorption on the removal of specific constituents from water, the continuous laboratory column studies provides the most practical application in water treatment. This is due to the fact that high adsorption capacities in equilibrium with the influent concentration rather than the effluent concentration can be achieved (Eckenfelder, 1989).

Adsorption of a packed bed column is a time and distance dependent process. During adsorption, each adsorbent particle in the column bed accumulates adsorbate particles from the influent solution as long as the state of equilibrium is reached. This equilibration process continues successively, layer by layer, from the column inlet to the column exit (Worch, 2012). During adsorption process, variables such as particle size (of adsorbent), fluid velocity, and bed dimensions (depth and diameter) determine pressure drop in the column and have an impact on the economics of the process as well as the extent of axial mixing and heat transfer properties.

The most important characteristic of the packed bed column adsorption is the record (history) of effluent concentration (Tien, 1994). The breakthrough curves also commonly referred to concentration-time curves, and the time at which the effluent concentration reaches the maximum allowable value is called the breakthrough time.

In these column studies, the flow of the solution can be either in the upward direction or the downward direction. Consider a flow downward through a fixed bed of adsorbents; if (a) external and internal mass transfer resistance are minute, (b) plug flow is realized, (c) axial dispersion is insignificant, (d) adsorbent is initially free of the adsorbate and (e) adsorption isotherm begins at the origin, then the local equilibrium between adsorbent and influent is instantaneously achieved.

In the upper part of the column bed, the adsorbent is saturated with adsorbates and the concentration of the effluent reaches that of the influent. Hence the loading of the adsorbate on adsorbent is in equilibrium with the concentration of the feed. The upper part of the adsorbent is

spent while near the exit of the column there still exist the portion of adsorbate free (unused length of bed and mass of adsorbent).

The experiment continues until when the effluent concentration abruptly rises to the influent concentration, and this is the time the adsorption process is terminated. This is the breakthrough time.

2.7.1 Axial dispersion

When the fluid flows through a packed there is a tendency for axial mixing to occur (Ruthven, 1984). Any mixing in this system is detrimental as it reduces the performance and efficiency of the system. Minimizing this axial dispersion is of paramount importance and a major design objective in the designs of packed beds (Ruthven, 1984).

2.8 Design methods

Laboratory column experiments can be employed to simulate the potential performance of the adsorbent and results obtained extrapolated in the design of a real time filter devices (Tchobanoglous, Burton, & Stensel, 2003).

Under constant influent flow, the adsorption zone goes downward through the bed. As this zone nears the bottom of the column bed, the concentration of adsorbate in the effluent increases, and finally equals the feed adsorbate concentration. From this, the concept of breakthrough is realized (Eckenfelder, 1989). Breakthrough and saturation (exhaustion) are defined as phenomena when the ratio of effluent-to-influent concentrations are 5% and 95% respectively (Zhou, Zhang, Zhou, & Guo, 2004). Values obtained from column breakthrough and exhaustion are commonly used to evaluate adsorption parameters in column adsorption systems.

The design of packed bed columns can be done by using two different approaches; the kinetic method and scale-up procedure. In both methods, breakthrough curve from test column either laboratory or pilot scale is required. The column should be as large as possible to minimize side-wall effects.

To predict the behaviour of breakthrough curves in fixed-bed adsorption, various mathematical tools have been developed and applied. These tools are divided into two major groups, scale-up

method and breakthrough curve models (Worch, 2012). For this study, the scale-up method was selected. This method requires to determine the breakthrough curves from laboratory scale experiments as the basis for predicting the behaviour of breakthrough curves in full-scale applications in field conditions.

Furthermore, this method is based on the fundamental relationships among the operational parameters. However, the scale-up method does not give a deeper insight into the adsorption process mechanisms. The applicability of the scale-up methods is restricted to conditions such as specific similarity criteria, where results of the laboratory scale experiments should match the conditions in the field (Worch, 2012).

The breakthrough curve model, on the other hand, utilizes mathematical models that are based on equilibrium relationships and mass transfer equations. The models offer more flexibility in application. In principle, the behaviour of breakthrough curves can be predicted from separately determined isotherm and kinetic parameters. However, due to the complex nature of adsorption mechanisms, more or less simplifications are necessary. Thus, it is important to validate any selected model by means of experimental data. The validation steps makes it difficult and tedious to apply the breakthrough curve models (Worch, 2012). This is the reason these models were not applied for this study.

2.8.1 The kinetic method

This method employs the following kinetic equations:

$$\frac{C_e}{C_o} = \frac{K_1}{1 + \frac{eK_1}{Q} (q_oM - C_oV)} \dots\dots\dots (2.3)$$

Where C_e = effluent concentration, C_o = influent concentration, K_1 = rate constant, q_o = maximum solid-phase concentration of sorbed solute, M = mass of the adsorbent, V = throughput volume and Q = flowrate. The breakthrough volume V may be selected in the design of a column by assuming the LHS equals the RHS in Equation (3) and by cross multiplication it gives:

$$1 + \frac{eK_1}{Q}(q_oM - C_oV) = \frac{C_o}{C_e} \dots\dots\dots (2.4)$$

Taking natural logarithms on both sides of Equation (4) and rearranging it gives:

$$\ln\left(\frac{C_o}{C_e} - 1\right) = \frac{K_1q_oM}{Q} - \frac{K_1C_oV}{Q} \dots\dots\dots (2.5)$$

Now, from Equation (5), a plot of $\ln\left(\frac{C_o}{C_e} - 1\right)$ against V will give a slope $\frac{K_1C_o}{Q}$ from which the design rate constant, K_1 , can be calculated and the design maximum solid-phase concentration, q_o (g/g), calculated from the intercept of the equation (5).

The amount (in kilograms) of adsorbent (GAC) required for the design of column is estimated using equation (5) by substituting parameters calculated from the plot of

$\ln\left(\frac{C_o}{C_e} - 1\right)$ Against V .

Equations (6) – (8) yields other parameters to be used in the design of the packed bed column.

$$\text{Column height} = \frac{\text{Volume of bed}}{\text{Cross-sectional area}} \dots\dots\dots (2.6)$$

$$\text{Diameter of the column (d)} = \frac{\sqrt{4xCSA}}{\pi} \dots\dots\dots (2.7)$$

$$\text{Breakthrough time} = \frac{\text{Volume at breakthrough}}{\text{Volumetric flowrate}} \dots\dots\dots (2.8)$$

The present work was carried out to evaluate the ability of Cashew Nut Shells Activated Carbon (CNSAC) to adsorb hardness causing ions from groundwater and make it palatable using a fixed bed adsorption column. In this study, the design of a packed bed column from the breakthrough parameters obtained from laboratory column test followed the scale-up approach.

2.8.2 Scale-up method

Procedures for scale-up approach for packed bed column design are as follows (Okewale, Igbokwe, & Babayemi, 2015)

- (i) Use a pilot test column filled with adsorbents (GCNSAC) to be used in full scale
- (ii) Apply filtration rate and Empty Bed Contact Time (EBCT) which shall be same in full scale
- (iii) Obtain the breakthrough curve
- (iv) Use breakthrough curve for scale-up

2.9 Contribution of this study to the body of knowledge

The purpose of this study was to investigate the effectiveness and the performance of activated carbon generated from cashew nut shells in softening hard water from groundwater and designing of a facility to treat water hardness at the point of use.

The need to study and design a filter for hardness removal, is underscored by the primary right of human beings to access potable water (Haugen, 2010). The central part of Tanzania is currently experiencing rapid population growth among reasons being the decision by the government of Tanzania to shift its headquarters to Dodoma. Population increase and climate change stresses the availability of potable water to every person (Vörösmarty, Green, Salisbury, & Lammers, 2000). Tanzania, like other countries in the third world is affected by water crisis and suffers from serious water scarcity. Available groundwater sources have high levels of water hardness (Knivslund, 2012; Napacho & Manyele, 2010).

It is of paramount importance to treat this water with recorded high levels of hardness and make it palatable. Most of the available facilities slightly purifies and/or improves the taste of water and some doesn't treat hardness at all. Other methods available are expensive in operation and maintenance and they need skilled personnel to operate. Most of these other technologies are not affordable to many Tanzanians in the rural setting.

Despite of abundance of adsorbent materials in Tanzania, there is no published information to reveal the application of the adsorbents in hardness removal, nor reports on water filters utilizing such adsorbents for water hardness removal to accepted levels.

CHAPTER THREE

MATERIALS AND METHODS

3.1 Study location

Groundwater sample in this study was collected in Mbande village, Sejeli ward – Kongwa district, Dodoma region. Kongwa district is located about 86 km on the eastern part of Dodoma, the capital city of Tanzania. It is among the seven districts of Dodoma region. The district has an area of 4041 km² with 3 divisions, 22 wards, 74 villages and 332 sub-villages. Kongwa borders Chamwino district on the west, Kiteto district (Manyara region) on the North, Kilosa district (Morogoro region) on the East and Mpwapwa district on the south. According to the national population and household census of 2012, the district has a population of 309973(NBS, 2012). Field hard water samples from Kongwa were analysed at the Ministry of Water – Dodoma laboratory and at the NM-AIST laboratory, Arusha. The borehole sample is found at following coordinates; UTM 37M 203894.01E/9324436.93S

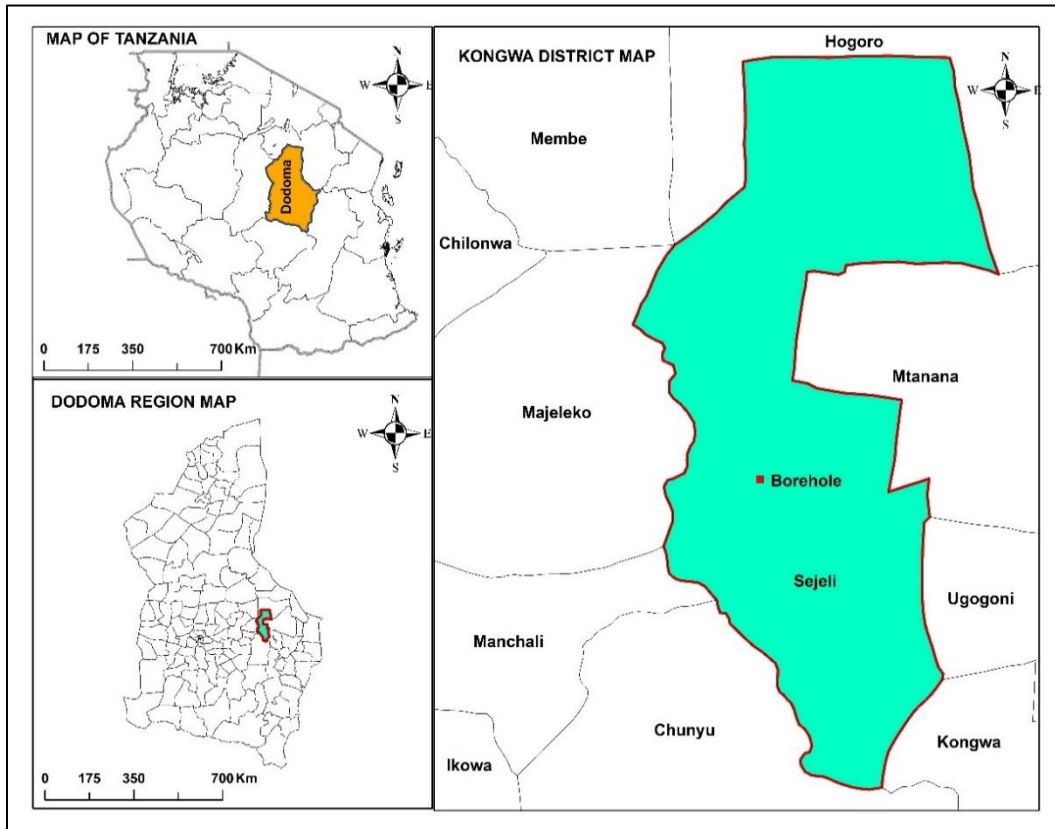

Figure 3:Kongwa District map

3.2 Materials

3.2.1 Adsorbates

(i) Synthetic hard water

Materials used for the preparation of synthetic hard water include; Calcium Chloride (CaCl_2), Magnesium Sulphate (MgSO_4) and 1.0 Litre of De-ionized water.

Other equipments were; beakers, conical flasks, stirrer, digital pH meter and a balance.

(ii) Field groundwater

For collection and sampling of groundwater equipments used were; hand gloves, polyethylene bottles, pH meter, and GPS.

3.2.2 Adsorbent

The GCNSAC was prepared as reported in a previous study by Rolence *et al.* (2014). The GCNSAC of 0.43 mm to 1.18 mm particle size range was used. Synthetic hard water was prepared as reported in the aforementioned study; where 1.19 g of CaCl_2 and 1.0 g of MgSO_4 were dissolved in 1.0 L of deionized water to make hard water with 1278.5 mg/L as CaCO_3 hardness concentration and this solution was stocked.

Table 6: Parameters recorded from the field hard water

Parameter	Unit	Measured Value	TZ 789:2016
Temperature	Celsius	25.8	Nm
Taste	nm	salty	no
Odour	nm	none	No
pH	nm	6.66	5.5 to 9.5
Conductivity	µS/cm	4624.0	2500.0
TDS	mg/L	2286.0	1500
Colour	TCU	40.0	50.0
Turbidity	NTU	0.46	25
Total Alkalinity	mg/L CaCO ₃	400	n.m
Non CO ₃ hardness	mg/L CaCO ₃	1772.0	nm
Total Hardness	mg/L CaCO ₃	2172.0	600
Calcium	mg/L	476.0	150
Magnesium	mg/L	286.6	100
Chloride	mg/L	1127.1	250
Sulphate	mg/L	1105.0	400
Nitrate	mg/L	548.0	45
Nitrite	mg/L	0.049	0.03
Nitrate-N	mg/L	123.9	nm
Orthophosphate	mg/L	0.60	2.2
Fluoride	mg/L	0.52	1.5
Copper	mg/L	-	1
Iron	mg/L	0.04	1.0
Manganese	mg/L	-	0.5
Potassium	mg/L	22	nm
Sodium	mg/L	292.0	200
Salinity	ppt	2.3	nm
E-Coli	Counts/100mls		0

*no – not objectionable; *nm – not mention

3.3 Methods

3.3.1 Characterization of field groundwater

Field hard water with hardness concentration of 2172.0 mg/L as CaCO₃ was collected from a borehole in Kongwa district Dodoma, Tanzania. This sample was stored below 4°C temperature to avoid microbial activities. All reagents used for this study were of analytical grade. Other water sampling procedures were followed as stipulated in the guidelines by the American Public Health Association (APHA-AWWA/WEF, 1998). Other field water parameters tested are as shown in Table 6.

3.3.2 Production of an activated carbon

Cashew-nuts were purchased from Coastal region, in Tanzania. The raw cashews after removal of the endosperm was washed with water thoroughly to remove any dirt and earthy matter before sun dried for 24 hours and later oven dried at 105°C for another 24 hours. The oven dried cashew-nut shells were subjected into a furnace and pyrolyzed at 400°C for 1 hour. The activated carbons were then soaked in KOH solution for 24 hours.

3.4 Experiments

Fixed bed column studies were carried out by using a glass column of 30 mm internal diameter and 600 mm length Fig. 3. Granular activated carbon (GAC) prepared from cashew nut shells having 0.425 mm to 1.18 mm particle size range was used. The activated carbon was packed in the column preceded with a layer of glass wool at the bottom, and glass balls at the top. The column was equipped with rubber stoppers at both ends to avoid bed lifting, and the constant bed height of 200 mm was used.

To prevent and minimize the possibility of wall and axial dispersion effects in the column, it is recommended that the ratio between bed length and particle size diameter be greater than 20 (Zhou *et al.*, 2004). The container with synthetic hard water was placed at a higher elevation to allow for gravity flow towards the column. The container at a higher elevation delivered the solution to the second container at a constant predetermined flowrate. The second container was fitted with a pipe to maintain a constant level of the solution in the container to avoid flow

fluctuations during the passage of water through the column. The containers were equipped with gate valves to control the flow.

When the adsorbate passed through the bed, it continuously meets fresh adsorbents and tends to create new equilibrium. Yet, due to the limited contact time with given part of the adsorbent, a true equilibrium was not attained. Operating variables in these experiments were flowrate (FR), which is the volume flowrate of the influent per unit cross sectional area of the adsorbent bed, bed depth (H), the influent concentration (C_0) and the bed diameter. The values of these variables used in this study are summarised in Table 7 as follows:

Table 7: Column design parameters from optimization experiments

Parameter	Value
Flowrate (mL/min)	2.0 – 2.5
Bed depth (mm)	200.0
Influent hardness (mg/L as CaCO_3)	1278.5
Bed diameter (mm)	30

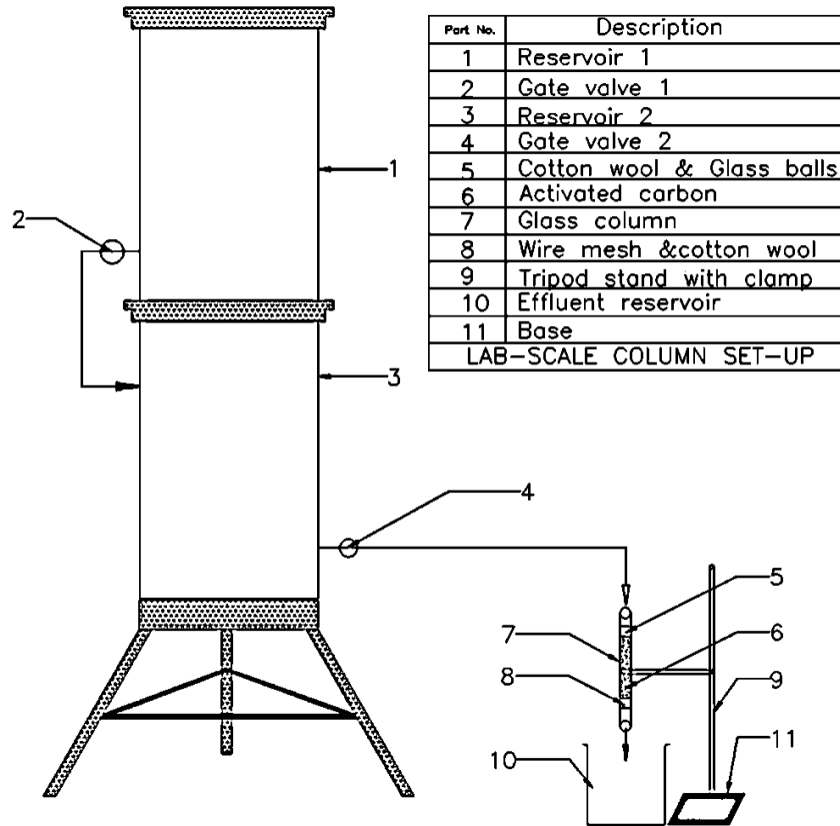

Figure 4: Schematic diagram of the experimental setup for laboratory packed-bed column adsorption studies

The experiments were conducted by varying the flowrate and influent concentration of the solution while keeping the bed height of the column constant. Flowrates of 2.0 and 2.5 mL/min were used with 1278.5 and 2172.0 mg/L as CaCO₃ influent concentrations for synthetic and field hard water, respectively. Effluent samples were collected at specified intervals (25 – 40 minutes) and analysed for residue hardness concentration by titration using a DIT 50 Behrotest® titrator. The experiment was terminated upon saturation. Adsorption capacity q_e was determined by using the following Equation (9) (Crittenden & Thomas, 1998):

$$\text{Adsorption capacity} \quad q_e = \frac{V \times (C_o - C_e)}{S} \quad \dots\dots\dots (3.1)$$

Where: V is volume in litres, C_o is initial hardness in mg/L, C_e is effluent hardness in mg/L and S is the GCNSAC's weight, in g.

CHAPTER FOUR

RESULTS AND DISCUSSION

4.1 Breakthrough point

At the start of the experiment, the hardness level in the effluent was low compared to the influent concentration. This was due to the initial high efficiency of the GCNSAC material in the column. As time progressed, the effluent hardness kept increasing proportionally to the decreasing adsorption capacity of the GCNSAC. In the end, the effluent hardness level was equal to that of the influent. This endpoint means that the adsorption efficiency in the column was zero. At this point, the GCNSAC was fully saturated with Ca^{2+} and Mg^{2+} ions (Okewale *et al.*, 2015). The breakthrough point is the time at which the effluent concentration reaches a specific concentration of interest (Eckenfelder, 1989). In this case, the breakthrough was reached when the effluent concentration reached Tanzania hardness standard in drinking water i.e. 600 mg/L. This happened after 240 minutes and 420 minutes for field hardwater and synthetic hardwater respectively. Two types of breakthrough curves were plotted: (1) effluent concentration (C_e) versus time Fig. 4 for the synthetic hard water and (2) effluent concentration (C_e) versus time for the field hard water Fig. 5.

4.1.1 Effect of synthetic hard water flowrate on breakthrough time

The effect of flowrate on hardness removal by GCNSAC was studied by varying the flowrate between 2.0 and 2.5 mL/min, while maintaining a constant bed height of 200 mm and influent concentration of 1278.5 mg/L as CaCO_3 .

Figure 4 indicates that there was a slight difference in time to reach the breakthrough point. Both 2.0 and 2.5 mL/min flowrates had around 180 min as their breakthrough time. This may be attributed to the fact that for the synthetic hard water there was not much competition for the binding sites because the water was spiked with only one contaminant. The initial hardness level for the synthetic hard water was low compared to that of the field hard water.

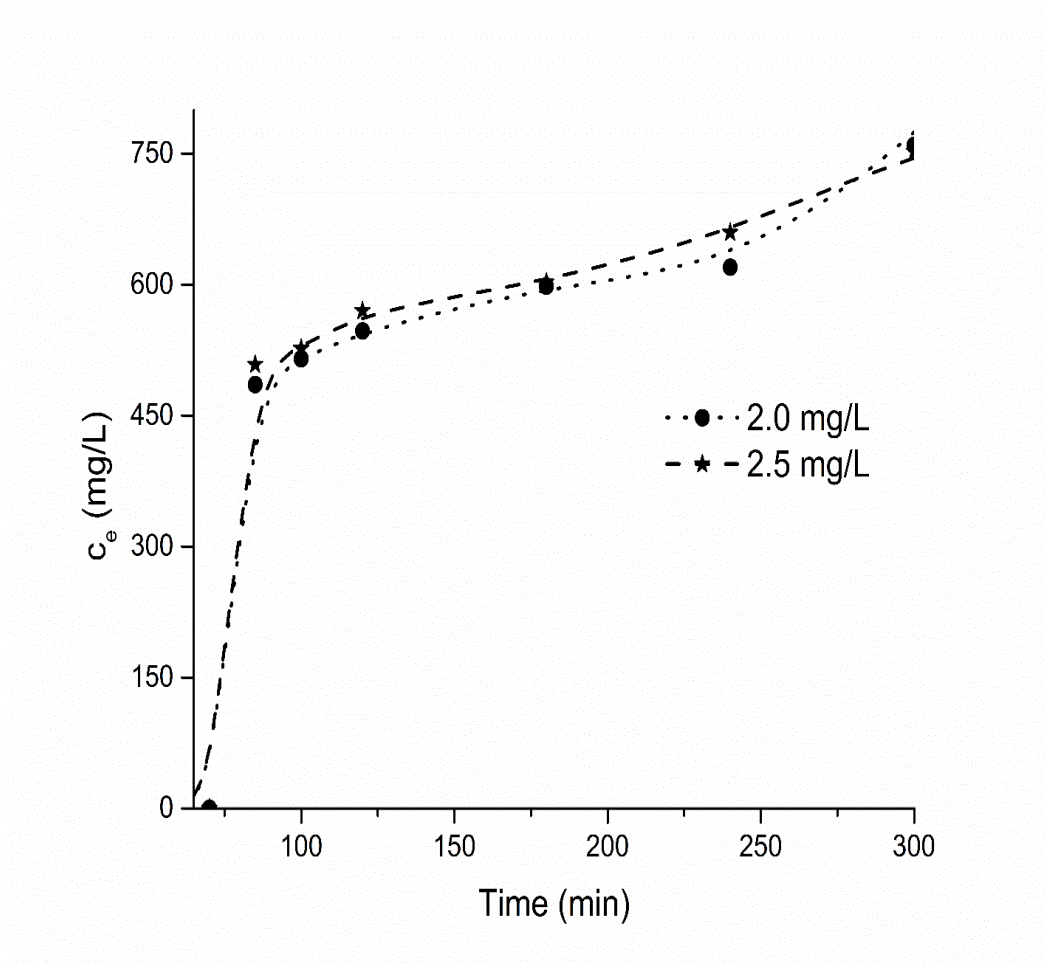

Figure 5: Effluent concentration versus time for synthetic hard water

4.1.2 Effect of field hard water flowrate on breakthrough time

As Fig. 5 indicates, the breakthrough time decreased from 430 to 360 min as flowrate increased from 2.0 to 2.5 mL/min, respectively. As it can be seen in figure 5, when the flowrate was low, it took longer time to reach the breakthrough point. This phenomenon may be attributable to the fact that, at lower flowrates, the movement of Ca^{2+} and Mg^{2+} into the pores of the GCNSAC is slow; the GCNSAC required more time to capture and bind the ions.

Moreover, it was noted that as the flowrate increased, the breakthrough time was decreased. The curve became steeper with increased flowrate and reached the breakthrough point faster. This implies that, the mass transfer zone was shortened indicating effective intraparticle diffusion effects (Rocha, Franca, & Oliveira, 2015). When the hard water flowrate was increased, it led to

the reduced rate of adsorption which is due to the limited residence time of the hard water in the column (Sivakumar & Palanisamy, 2009). Increasing flowrate reduced the lifespan of the GCNSAC in the column and hence a quick saturation of the column bed.

Also, Fig. 5 indicates how changes in effluent hardness of field water influenced the breakthrough time. Field hard water with total hardness of 2172.0 mg/L as CaCO₃ was used for this experiment. The bed height as well as the inlet flowrates were the same as the ones used in the previous experiment.

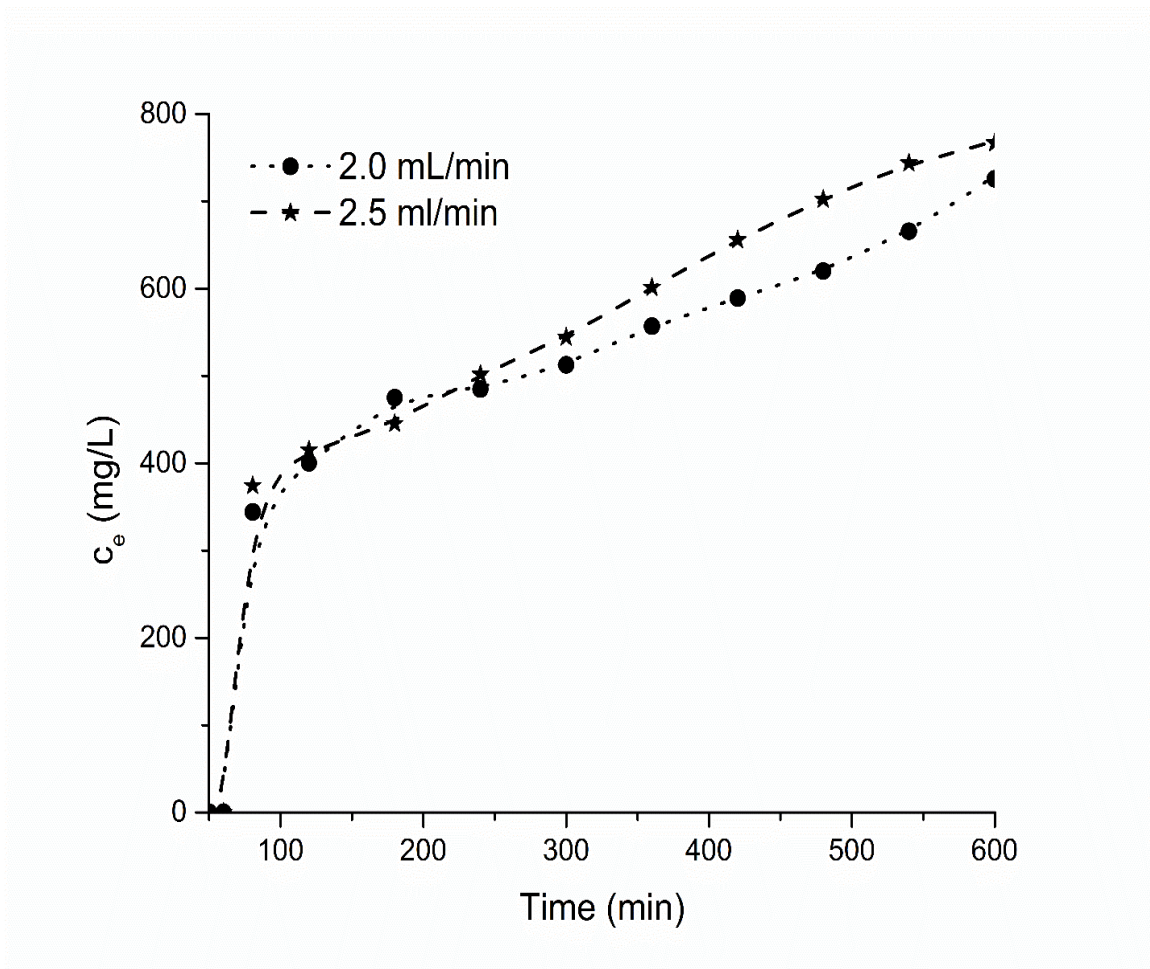

Figure 6: Effluent concentration versus time for field hard water

When compared to results of the synthetic hard water, it is clear that breakthrough curves for the field hard water became steeper Fig. 5 and breakthrough time became shorter (Table 8). This

change in both the breakthrough curves and time could be attributed to the higher initial hardness in the field hard water compared to the initial hardness of the synthetic hard water. The steeper breakthrough curves and reduction in breakthrough time may also be attributable to low mass transfer flux from the solution onto the particle surface because of weak driving forces (Baek *et al.*, 2007; Gupta & Babu, 2009).

High water hardness meant that the abundance and availability of hardness-causing ions also increased and quickly populated the binding sites (Ko, Porter, & McKay, 2005). Another reason for steeper curve and shorter breakthrough time could be the fact that unlike the synthetic hard water, the field hard water had other contaminants that were competing with hardness-causing ions for the binding sites.

4.1.3 Hardness removal capacity vs. time

Figure 6 and 7 show the adsorption capacity versus time at different influent flowrates for both synthetic hard water and field hard water. At a lower flowrate the synthetic hard water reached maximum sorption capacity (70.0 mg/g) at around 100th min. The field hard water with a lower flowrate reached maximum sorption capacity (125.0 mg/g) at around the 80th min. This difference may be attributed to the lower influent hardness levels in the synthetic hard water compared to the higher initial hardness level in the field water. Furthermore, in the field hard water there were other pollutants apart from the hardness-causing ions. These other pollutants may have contributed to fast achieving of the maximum sorption capacity by the field hard water (Senthilkumar, Varadarajan, Porkodi, & Subbhuraam, 2005).

On the other hand, increasing the flowrate does not cause a notable difference for the synthetic hard water. But for the field hard water, at a faster flowrate, the time taken to reach maximum sorption slightly increased. This slight increase in the time needed to reach saturation may be attributed to minimized retention time of the hard water in the column. Furthermore, faster flowrates would mean that the rate of mixing in the column also increases. With increased mixing, it would require slightly more time for the GCNSAC particles to reach saturation. This also means that if the influent concentration entering a column is high, increasing the flowrate would also cause a slight increase in the time needed to reach maximum adsorption capacity (Senthilkumar *et al.*, 2005).

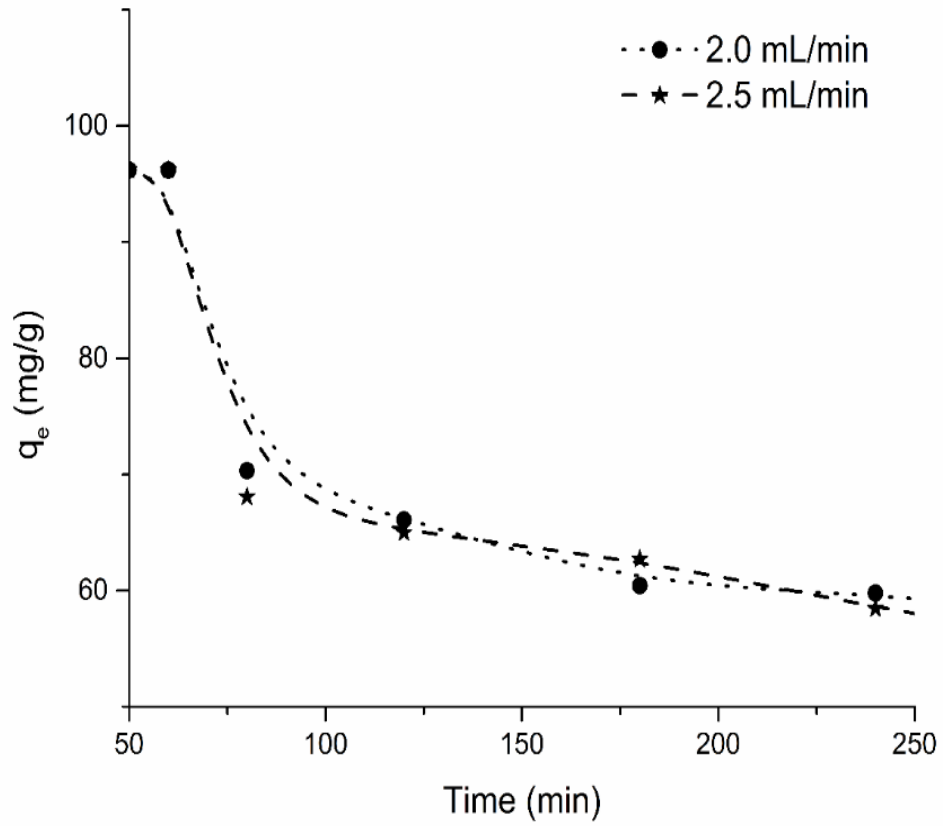

Figure 7: Variations in the sorption capacity of the GCNSAC during hardness uptake from synthetic hard water at flowrates of 2.0 and 2.5 mL/min.

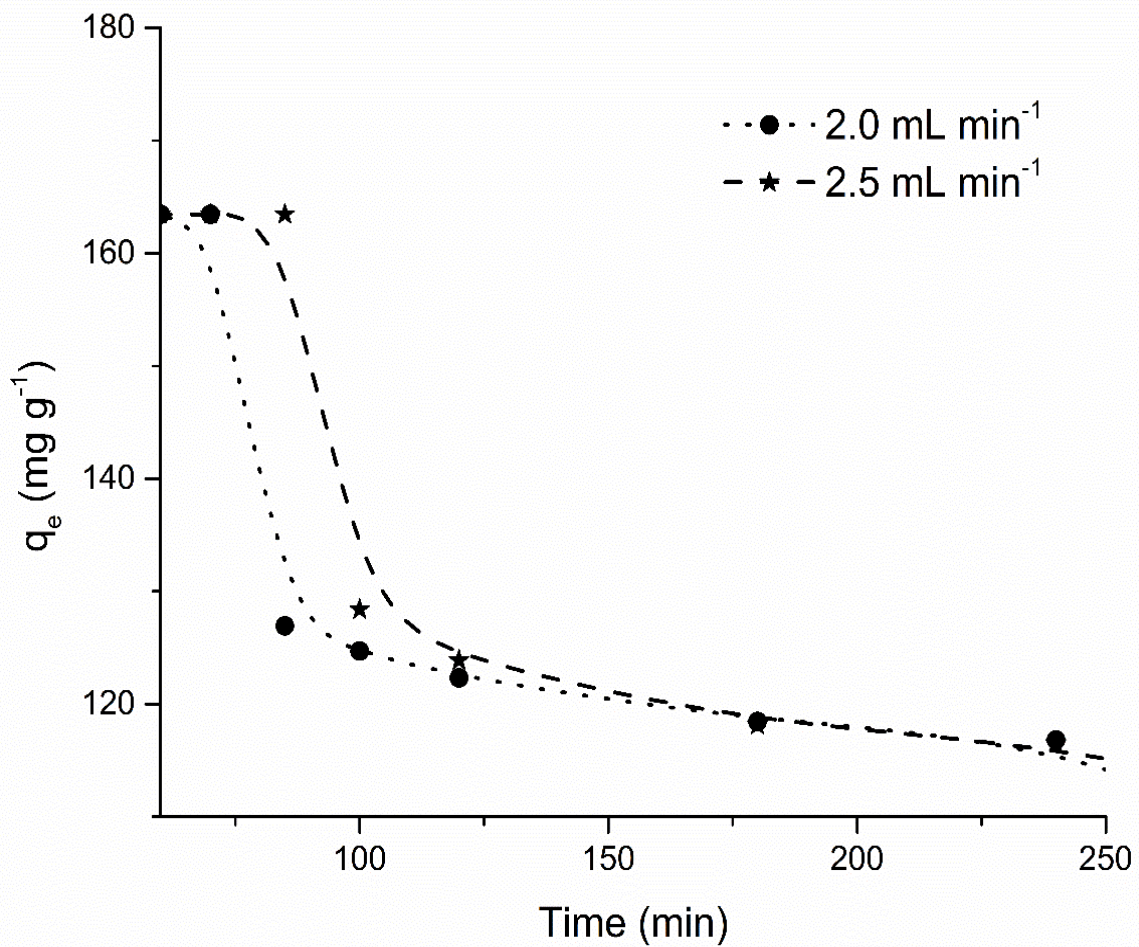

Figure 8: Variations in sorption capacity of the GCNSAC during hardness uptake from field hard water at flow rates of 2.0 and 2.5 mL/min.

Table 8: Breakthrough time versus influent concentration gradient and flowrate

Influent hardness (mg/L)	Influent flowrate (mL/min)	Breakthrough time (min)
Synthetic hard water		
1278.5	2.0	420
	2.5	360
Field hard water		
2172.0	2.0	240
	2.5	180

4.2 Pilot column design

The laboratory-scale column tests were used to get parameters for the full-scale design of the packed bed column for field application. The same filtration rate and bed depth which were used in the pilot laboratory experiments were also used in designs for field application.

Data used from the laboratory pilot column tests included: the flowrate (Q) of 2.0 mL/min, column diameter (D) of 30.0 mm, column bed depth (H) of 200.0 mm, density of adsorbents (GCNSAC) of 0.47 g/mL. Other information used in the design were the breakthrough volume from breakthrough curve of 560 mL and the volume at capacity exhaustion of 1200.0 mL. To determine the required filtration rate, the following Equations (10 and 11) were employed:

$$Filtrationrate(FR) = \frac{Q(flowrate)}{A(cross-sectionalarea)} \dots\dots\dots(4.1)$$

Where:

$$Area (A) = \frac{\pi d^2}{4} \dots\dots\dots(4.2)$$

Data used for the determination of filtration rate (FR) included: the diameter (*d*) of laboratory test column of 3 cm which yielded an area of 7.07 cm². Since the flowrate was 2 cm³/min and area (*A*) = 7.07 cm²; the filtration rate obtained was 0.283 cm³ min⁻¹, applicable for the field packed-bed column. To determine the area of the packed-bed column to be used onsite, the following Equation (12) was used:

$$Area = \frac{Q(Flowrate)}{FR(filtrationrate)} \dots\dots\dots(4.3)$$

Taking into consideration the onsite conditions, the assumed flowrate of the packed bed column design was 75 cm³/min; therefore, the obtained area (*A*) was 265.02 cm². Since $Area (A) = \frac{\pi d^2}{4}$, the column diameter obtained, *d*, was equal to 18.37 cm.

In this study, the time between a treatment cycle and the next cycle i.e. the empty bed contact time (EBCT) was also estimated using Equation 13. For this estimation the assumption was that the fluid used the same flowrate across the GCNSAC from entry to exit.

$$\tau(Emptybedcontacttime) = \frac{Volumeofbed}{Q(flowrate)} \dots\dots\dots(4.4)$$

The volume of bed = *A* (cross-sectional area) x bed height = 141.4 cm³. EBCT = 70.7 min. Thus, the estimated EBCT was 70.7 min.

The column bed height was computed by using the EBCT and the filtration rate (FR) where the height (*H*) = EBCT x FR = 70.69 x 0.283 = 20.0 cm. This height is the same as the height of laboratory test column because the height of the column is set by EBCT (τ) and filtration rate (FR) and these are the same for both laboratory test column and the field packed-bed column.

The mass of the GCNSAC needed to complete one cycle of hardness treatment was computed by using the volume of packed column = Cross-sectional area (A) x Height (H).

$$\text{Volume of packed column} = \frac{3.142 \times 18.37 \times 18.37}{4} \times 20.007 = 5301.45 \text{ cm}^3$$

Thus, mass of the adsorbent = Density of adsorbent x volume

$$= 0.47 \times 5301.45 = 2491.68 \text{ g} = 2.49 \text{ kg}$$

Thus, approx. 2.5 kg of GCNSAC is required to treat approx. 5.0 litres of hard water in one treatment cycle. With these measurements, a user at the POU is able to filter approximately four litres of drinking water in a span of 60 minutes. Considering that in many rural settings in sub-Saharan Africa, a person uses approximately 25 litres of water per day, the above design is appropriate for such rural settings. A summary of all the design parameters used in this study is provided in Table 9.

Table 9: A summary of a filtration system design parameters

Design Parameter	Value	Unit of measurement	Remarks
Flowrate	2.0	mL/min	Same flowrate used in the laboratory to be used in field application
Column diameter	18.4	cm	-
EBCT	70.7	min	-
Bed depth	20	cm	Same bed depth used in the laboratory to be used in field application
Quantity of adsorbent per cycle of experiment	2.5	kg	-

CHAPTER FIVE

CONCLUSION AND RECOMMENDATIONS

5.1 Conclusion

It has been demonstrated that, activated carbon from cashew nut shells in a fixed bed column setting, successfully removed total hardness from groundwater collected from a borehole in Kongwa and synthesized hard water from the laboratory.

- (i) Removal of total hardness (CaCO_3) depends on hydraulic loading rate, influent concentration and column bed depth.
- (ii) Granular activated carbons (GACs) have been applied in many previous studies to decontaminate water. However, most of the previous studies used the GACs to remove other contaminants e.g. heavy metals, odour, and fluoride. This study used the GACs to successfully remove hardness from both synthetic hard water and field groundwater.
- (iii) Additionally, most of the previous studies that attempted to remove water hardness used batch setting using Powdered Activate Carbon (PAC). In this study, we successfully removed hardness from both synthetic hard water and real field groundwater using a column setting. The results show that, the GCNSAC may be applied as the filter-medium in the fabrication of filters for hardness removal. The effects of flowrate and initial hardness concentration from groundwater on breakthrough curves and adsorption capacity were also examined. For synthetic hard water, it was revealed by the present study that, the adsorption capacity and breakthrough time declined with increasing flowrate. However, for the field groundwater, the breakthrough curves were steeper and the breakthrough time was quickly reached.
- (iv) In the present study, we developed and tested various filtration parameters and the results indicated that these parameters can be used for designing a hard water filter that can be affordably used in rural settings in most developing countries.

5.2 Recommendations

Further studies on regeneration of the biosorbents are recommended, as it is of crucial importance in the sustainability of the processes. Regeneration aims at producing small volume of metal concentrates suitable for recovery process, without damaging the capacity of adsorbent making it reusable in several adsorption and desorption cycles.

Fabrication of the filter and testing its performance as compared to the laboratory setting is also recommended.

Also, studies on the filter clock are recommended, this will enable the determination of saturation time of the bed and consequently replace with a new one and the other one for regeneration.

REFERENCES

- Adamson, A. W., & Gast, A. P. (1967). *Physical chemistry of surfaces*: Interscience.
- APHA-AWWA/WEF. (1998). *Standard Methods for the Examination of Water and Wastewater*, 20th Edition. Washington DC, USA: American Public Health Association/American Water Works Association/Water Environment Federation.
- Baek, K. W., Song, S. H., Kang, S. H., Rhee, Y. W., Lee, C. S., Lee, B.-J., Hwang, T. S. (2007). Adsorption kinetics of boron by anion exchange resin in packed column bed. *Journal of Industrial and Engineering Chemistry*, 13(3), 452-456.
- Bansal, R. C., & Goyal, M. (2005). *Activated Carbon Adsorption*: CRC press.
- Baumgartner, J., Murcott, S., & Ezzati, M. (2007). Reconsidering 'appropriate technology': the effects of operating conditions on the bacterial removal performance of two household drinking-water filter systems. *Environmental Research Letters*, 2(2), 024003.
- Cassivi, A., Johnston, R., Waygood, E. O. D., & Dorea, C. C. (2018). Access to drinking water: time matters. *Journal of Water and Health*, 16(4), 661-666.
- Biosand Filter Manual, Design, Construction, Installation, Operation and Maintenance, (2009).
- Çeçen, F., & Aktas, Ö. (2011). *Activated Carbon for Water and Wastewater Treatment: Integration of Adsorption and Biological Treatment*: John Wiley & Sons.
- Corbitt, R. A. (1990). *Standard handbook of environmental engineering*: McGraw-Hill.
- Crittenden, B., & Thomas, W. J. (1998). *Adsorption Technology and Design*: Elsevier.
- Eckenfelder, W. W. (1989). *Industrial Water Pollution Control*: McGraw-Hill.
- El-Sayed, G. O. (2010). Removal of water hardness by adsorption on peanut hull. *Journal of International Environmental Application & Science*, 5(1), 47-55.
- Elisante, E., & Muzuka, A. N. (2017). Occurrence of nitrate in Tanzanian groundwater aquifers: a review. *Applied Water Science*, 7(1), 71-87.

- EWURA. (2015/2016). *Districts and Small Towns Water Utilities Performance Report*.
- Fahmi, M. R., Nor Wahidatul Azura, Z. N., Pang, C. P., & Nasrul, H. (2011). Mechanism of turbidity and hardness removal in hard water sources by using *Moringa oleifera*. *Journal of Applied Sciences*, 11(16), 2947-2953.
- Frankel, V. (2011). *Seawater Desalination: Trends and Technologies: USA: Kennedy/Jenks Consultants*.
- Freundlich, H. (1906). Over the adsorption in solution. *Journal of Physical Chemistry*, 57(385471), 1100-1107.
- Gayatri, S. L., & Ahmaruzzaman, M. (2010). Adsorption technique for the removal of phenolic compounds from wastewater using low-cost natural adsorbents. *Assam University Journal of Science and Technology*, 5(2), 156-166.
- Gray, N. F. (2008). *Drinking Water Quality: Problems and Solutions: Cambridge University Press*.
- Gupta, S., & Babu, B. (2009). Modeling, simulation, and experimental validation for continuous Cr (VI) removal from aqueous solutions using sawdust as an adsorbent. *Bioresource Technology*, 100(23), 5633-5640.
- Haugen, H. M. (2010). Human Rights Impact Assessment in the Context of Biofuels: Addressing the Human Right to Food and the Human Rights to Water. *Nordic Journal of Human Rights*, 28, 39.
- Hendricks, D. (2006). *Water Treatment Unit Processes: Physical and Chemical: CRC press*.
- Hiji, M. F., & Ntalikwa, J. W. (2014a). Investigations of Dodoma municipal hard water (Part 1): Review of hard water treatment processes and identification of contaminants. *International Journal of Environmental Monitoring and Protection*, 1(3), 56.

- Hiji, M. F., & Ntalikwa, J. W. (2014b). Investigations of Dodoma municipal hard water:(Part 1): Review of hard water treatment processes and identification of contaminants. *International Journal of Environmental Monitoring and Protection*, 1(3), 56.
- Howe, K. J., Crittenden, J. C., Hand, D. W., Trussell, R. R., & Tchobanoglous, G. (2012). *Principles of water treatment*: John Wiley & Sons.
- Idris, S., Iyaka, Y., Dauda, B., Ndamitso, M., & Umar, M. (2012). Kinetic study of utilizing groundnut shell as an adsorbent in removing chromium and nickel from dye effluent. *American Chemical Science Journal*, 2(1), 12-24.
- Johnson, R. (2015). *Drinking Water Quality: Testing and Interpreting Your Results (Revised)*. Retrieved from North Dakota, USA: <https://www.ag.ndsu.edu/publications/environment-natural-resources/drinking-water-quality-testing-and-interpreting-your-results/wq1341>
- Knivslund, S. M. (2012). Water chemistry in the Bahi-Manyoni basin in Tanzania. Master's Thesis.
- Ko, D. C., Porter, J. F., & McKay, G. (2005). Application of the concentration-dependent surface diffusion model on the multicomponent fixed-bed adsorption systems. *Chemical Engineering Science*, 60(20), 5472-5479.
- Langmuir, I. (1916). The constitution and fundamental properties of solids and liquids. Part I. Solids. *Journal of the American Chemical Society*, 38(11), 2221-2295.
- Mackintosh, G., & Colvin, C. (2003). Failure of rural schemes in South Africa to provide potable water. *Environmental Geology*, 44(1), 101-105.
- Manahan, S. E. (2011). *Fundamentals of Environmental Chemistry*: CRC press.
- Meena, K., Gunsaria, R., Meena, K., Kumar, N., & Meena, P. (2011). The problem of hardness in ground water of Deoli Tehsil (Tonk District) Rajasthan. *Journal of Current Chemical & Pharmaceutical Sciences*, 2(1), 50-54.
- Merrywater. (2017). Water Filters.

- Mihayo, I., & Mkoma, S. (2012). Chemical water quality of bottled drinking water brands marketed in Mwanza city, Tanzania. *Research Journal of Chemical Sciences*, 2(7), 21-26
- Mintz, E., Bartram, J., Lochery, P., & Wegelin, M. (2001). Not just a drop in the bucket: expanding access to point-of-use water treatment systems. *American Journal of Public Health*, 91(10), 1565-1570.
- Momba, M., Obi, C., & Thompson, P. (2009). Survey of disinfection efficiency of small drinking water treatment plants: Challenges facing small water treatment plants in South Africa. *Water Sa*, 35(4).
- MoWI. (2015). *Water Quality YEar Book - Dodoma Region*.
- Mulder, J. (2012). *Basic Principles of Membrane Technology*: Springer Science & Business Media.
- Murcott, S. (2006). Implementation, Critical Factors and Challenges to Scale-Up of Household Drinking Water Treatment and Safe Storage Systems. In *Background paper on Household Water Treatment and Safe Storage (HWTS) for the electronic conference hosted by USAID/Hygiene Improvement Project (HIP)*.
- Muyibi, S. A., & Evison, L. M. (1996). Coagulation of turbid water and softening of hardwater with Moringa oleifera seeds. *International Journal of Environmental Studies*, 49(3), 247-259.
- Mwabi, J., Adeyemo, F., Mahlangu, T., Mamba, B., Brouckaert, B., Swartz, C., . . . Momba, M. (2011). Household water treatment systems: a solution to the production of safe drinking water by the low-income communities of Southern Africa. *Physics and Chemistry of the Earth, Parts A/B/C*, 36(14), 1120-1128.
- NABAKI. (2017). Water purification. Retrieved from <http://www.nabaki.com/category/water-purification-treatment>

- Napacho, Z., & Manyele, S. (2010). Quality assessment of drinking water in Temeke District (part II): Characterization of chemical parameters. *African Journal of Environmental Science and Technology*, 4(11), 775-789.
- NBS. (2012). Population and Housing Census. Retrieved from www.nbs.go.tz
- Okewale, A., Igbokwe, P., & Babayemi, K. (2015). Design of Pilot Plant Packed Column for the Dehydration of Water from Ethanol-Water Mixtures. *Advances in Chemical Engineering and Science*, 5(02), 152.
- Otero, M., Rozada, F., Calvo, L., Garcia, A., & Moran, A. (2003). Elimination of organic water pollutants using adsorbents obtained from sewage sludge. *Dyes and Pigments*, 57(1), 55-65.
- Pandey, P., Sharma, S., & Sambhi, S. (2010). Kinetics and equilibrium study of chromium adsorption on zeolite NaX. *International Journal of Environmental Science & Technology*, 7(2), 395-404.
- Poulopoulos, S. G., & Inglezakis, V. J. (2006). *Adsorption, Ion Exchange and Catalysis: Design of Operations and Environmental Applications*: Elsevier.
- Pritchard, M., Mkandawire, T., Edmondson, A., O'neill, J., & Kululanga, G. (2009). Potential of using plant extracts for purification of shallow well water in Malawi. *Physics and Chemistry of the Earth, Parts A/B/C*, 34(13-16), 799-805.
- Rittmann, B. E., & McCarty, P. L. (2012). *Environmental Biotechnology: Principles and Applications*: Tata McGraw-Hill Education.
- Rocha, P. D., Franca, A. S., & Oliveira, L. S. (2015). Batch and column studies of phenol adsorption by an activated carbon based on acid treatment of corn cobs. *International Journal of Engineering and Technology*, 7(6), 459.
- Rolence, C., Machunda, R. L., & Njau, K. N. (2014). Water hardness removal by coconut shell activated carbon. *International Journal of Science, Technology and Society*, 2(5), 97-102.

- Ruthven, D. M. (1984). *Principles of Adsorption and Adsorption Processes*: John Wiley & Sons.
- Rwiza, M. J., Oh, S.Y., Kim, K.W., & Kim, S. D. (2018). Comparative sorption isotherms and removal studies for Pb (II) by physical and thermochemical modification of low-cost agro-wastes from Tanzania. *Chemosphere*, 195, 135-145.
- Saeed, A. M., & Hamzah, M. J. (2013). New approach for removal of total hardness (Ca²⁺, Mg²⁺) from water using commercial polyacrylic acid hydrogel beads, study and application. *International Journal of Advanced Biological and Biomedical Research*, 1(9), 1142-1156.
- Senthilkumar, S., Varadarajan, P., Porkodi, K., & Subbhuraam, C. (2005). Adsorption of methylene blue onto jute fiber carbon: kinetics and equilibrium studies. *Journal of Colloid and Interface Science*, 284(1), 78-82.
- Seo, S. J., Jeon, H., Lee, J. K., Kim, G. Y., Park, D., Nojima, H., Moon, S.-H. (2010). Investigation on removal of hardness ions by capacitive deionization (CDI) for water softening applications. *Water Research*, 44(7), 2267-2275.
- Sepehr, M. N., Sivasankar, V., Zarrabi, M., & Kumar, M. S. (2013). Surface modification of pumice enhancing its fluoride adsorption capacity: An insight into kinetic and thermodynamic studies. *Chemical Engineering Journal*, 228, 192-204.
- Sepehr, M. N., Zarrabi, M., Kazemian, H., Amrane, A., Yaghmaian, K., & Ghaffari, H. R. (2013). Removal of hardness agents, calcium and magnesium, by natural and alkaline modified pumice stones in single and binary systems. *Applied Surface Science*, 274, 295-305.
- Shannon, M. A., Bohn, P. W., Elimelech, M., Georgiadis, J. G., Mariñas, B. J., & Mayes, A. M. (2008). Science and technology for water purification in the coming decades. *Nature*, 452(7185), 301-310.
- Shayo, N., Chove, B., Gidamis, A., & Ngoma, O. (2007). The quality of water in small community supplies of Kingolwira village, Morogoro, Tanzania. *Tanzania Journal of Health Research*, 9(1), 56-60.

- Sivakumar, P., & Palanisamy, P. (2009). Adsorption studies of basic Red 29 by a non-conventional activated carbon prepared from *Euphorbia antiquorum* L. *International Journal of ChemTech Research*, 1(3), 502-510.
- Skipton, S., Dvorak, B., & Niemeyer, S. (2008). Drinking water treatment: water softening (ion exchange). *University of Nebraska, Lincoln Extension, Institute of Agriculture and Natural Resources: Lincoln, NE, 1491*, 1-4.
- Suzuki, M., & Suzuki, M. (1990). *Adsorption Engineering* (Vol. 14): Kodansha Tokyo.
- Taras, M. J., & Association, A. W. W. (1981). Quest for pure water: the history of water purification from the earliest records to the twentieth century *Quest for pure water: the history of water purification from the earliest records to the twentieth century*: American Water Works Association.
- TBS. (2014). *TZS 574: 2002 Drinking (Potable) Water Specifications*.
- Tchobanoglous, G., Burton, F. L., & Stensel, H. D. (2003). *Wastewater Engineering Treatment and Reuse*: Boston, US: McGraw-Hill Higher Education.
- Tien, C. (1994). *Adsorption Calculations and Modeling*: Butterworth-Heinemann.
- UNGA. (2015). Sustainable Development goals.
- Van der Aa, M. (2003). Classification of mineral water types and comparison with drinking water standards. *Environmental Geology*, 44(5), 554-563.
- Vijayaraghavan, K., Padmesh, T., Palanivelu, K., & Velan, M. (2006). Biosorption of nickel (II) ions onto *Sargassum wightii*: application of two-parameter and three-parameter isotherm models. *Journal of Hazardous Materials*, 133(1), 304-308.
- Vörösmarty, C. J., Green, P., Salisbury, J., & Lammers, R. B. (2000). Global water resources: vulnerability from climate change and population growth. *Science*, 289(5477), 284-288.
- Weber, W. J., & Borhardt, J. A. (1972). *Physicochemical Processes for Water Quality Control* (Vol. 640): Wiley-Interscience New York.

- WHO. (2008). Guidelines for drinking-water quality: second addendum. Vol. 1, Recommendations. Geneva, Switzerland: World Health Organization.
- WHO. (2011). Hardness in Drinking-water. *Background Document for Development of World Health Organization Guidelines for Drinking-Water Quality*, 1-11.
- WHO, G. (2011). Guidelines for drinking-water quality. *World Health Organization*, 216, 303-304.
- WHO, U. (2017). Progress on drinking water, sanitation and hygiene: 2017 update and SDG baselines. *Switzerland: World Health Organization*.
- Worch, E. (2012). *Adsorption Technology in Water Treatment: Fundamentals, Processes, and Modeling*: Walter de Gruyter.
- Zeldowitsch, J. (1934). Adsorption site energy distribution. *Acta Physico-Chimica Sinica*, 1, 961-973.
- Zhou, D., Zhang, L., Zhou, J., & Guo, S. (2004). Development of a fixed-bed column with cellulose/chitin beads to remove heavy-metal ions. *Journal of Applied Polymer Science*, 94(2), 684-691.