

2020-04

# Removal of hydrogen sulfide from biogas using sweet potato's leaves derived activated carbon

Juma, Geni

NM-AIST

---

<https://doi.org/10.58694/20.500.12479/969>

*Provided with love from The Nelson Mandela African Institution of Science and Technology*

**REMOVAL OF HYDROGEN SULFIDE FROM BIOGAS USING  
SWEET POTATO'S LEAVES DERIVED ACTIVATED CARBON**

**Geni Juma**

**A Dissertation Submitted in Partial Fulfillment of the Requirements for the Degree of  
Master's in Materials Science and Engineering of the Nelson Mandela African  
Institution of Science and Technology**

**Arusha, Tanzania**

**April, 2020**

## ABSTRACT

Hydrogen sulfide gas contained in biogas is both corrosive and poisonous. In this study a performance of sweet potato leaves activated carbon for hydrogen sulfide removal from biogas was evaluated. The samples were synthesized through chemical activation method using potassium hydroxide as an activating agent. The study focused on the understanding of the effect of carbonization temperature during activated carbon making, KOH: C activation ratio, the flow rate of biogas and mass of sweet potato leaves activated carbon on adsorption capacity. The Brunauer-Emmett-Teller analysis was performed for both fresh and spent activated carbon as well as for carbonized sample, which was not activated. The activated carbon was also characterized by X-ray fluorescence and Carbon, Hydrogen, Nitrogen and Sulfur techniques for elemental analysis. The adsorption tests were conducted at the on-site biogas digester at ambient conditions. The adsorbent was packed into the reactor bed, biogas allowed to pass through the adsorbent, and the inlet and outlet concentrations of H<sub>2</sub>S were monitored. The results showed that the removal efficiency of hydrogen sulfide increased with increase carbonization temperature from 600 to 800 °C. The increase in the mass of sorbent from 0.4 g to 1.0 g also brought to the rise in removal efficiency from 88% to 95% under the lowest flow rate of about 0.02 m<sup>3</sup>/h with activation ratio 1:1 KOH: C at 800 °C which made a sorption capacity of approximately 1.9 g S/100 g, activated carbon. As per the mechanism of the hydrogen sulfide removal, it is not only contributed by the adsorption process with the pores available but also by the presence of iron in the sample that reacted with hydrogen sulfide. The regeneration test was done for the saturated sample to check the regenerative ability of the material and the result indicated that the sorption capacity of the regenerated sample was lower compared to the freshly prepared sample. Therefore, upon successful hydrogen sulfide sorption, sweet potato leaves activated carbon is viable adsorbent for removing H<sub>2</sub>S from biogas.

**DECLARATION**

I, **GENI JUMA**, do with this declare to the Senate of the Nelson Mandela African Institution of Science and Technology that this dissertation is my original work and that it has neither been submitted nor being concurrently submitted for degree award in any other institution.

.....

**Name and signature of candidate**

.....

Date

The above declaration is confirmed

.....

**Name and signature of supervisor 1**

.....

Date

.....

**Name and signature of supervisor 2**

.....

Date

## **COPYRIGHT**

This dissertation is copyright material protected under the Berne Convention, the Copyright Act of 1999 and other international and national enactments, in that behalf, on intellectual property. It must not be reproduced by any means, in full or in part, except for short extracts in fair dealing. For private researcher study, critical scholarly review or discourse with an acknowledgement, without written permission of the Deputy Vice-Chancellor for Academic, Research and Innovation, on behalf of both the author and the Nelson Mandela African Institution of Science and Technology.

## CERTIFICATION

The undersigned certify that they have read the dissertation titled “Removal of Hydrogen Sulfide from Biogas using Sweet potato’s leaves derived Activated Carbon” and recommended for examination in fulfilment of the requirements for the degree of Master’s in Materials Science and Engineering of the Nelson Mandela African Institution of Science and Technology.

.....

Dr. Revocatus Machunda

(Principal supervisor)

Date.....

.....

Prof. Tatiana Pogrebnaya

(Co - supervisor)

Date.....

## ACKNOWLEDGEMENTS

I would like to thank the almighty God for his endless boundaries of keeping my health and mental state fit to undertake studies at the Nelson Mandela African Institution of Science and Technology.

I am immensely grateful to supervisors Dr. Revocatus Machunda and Prof. Tatiana for their active supervision and upkeep through this research work.

I gratefully acknowledge the African Development Bank with grant No. 2100155032816 through Nelson Mandela African Institution of Science and Technology for the financial provision without which the current study could not be possible.

I am grateful to the School of Materials, Energy, Water, Environmental Science and Engineering (MEWES) for allowing me to use their school laboratory facilities. The advice and technical support from students in the Department of Materials, Energy Science and Engineering, Mr. Rene Costa, Mr. Amosi Makoye, Mr. Geradius Deogratias, Ms. Joyce Elisadikiel and Ms. Tusekile Alfred are appreciated.

I am thankful to Mr. Christopher Kellner from Sakina Arusha, Tanzania, for providing an opportunity for me to conduct sorption experiments within his residence house without forgetting Center for Agricultural Mechanization and Rural Technology institution for their instrumental support. The moral support from fellow students is also acknowledged.

Moreover, I am very thankful to my lovely husband, Mr. Derick Kaijage, for taking care of the family in my absence. I thank my beloved kids, Brenda and Barbara, for their encouragement and prayers, and I thanked them for the patient when they missed my parental care, especially during coursework moment. Lastly, I acknowledge my parents for sending me to school without which I would not have reached where I am.

## **DEDICATION**

I dedicate this work to my family.



## TABLE OF CONTENTS

ABSTRACT.....	i
DECLARATION .....	ii
COPYRIGHT.....	iii
CERTIFICATION .....	iv
ACKNOWLEDGEMENTS .....	v
DEDICATION .....	vi
TABLE OF CONTENTS.....	viii
LIST OF TABLES .....	x
LIST OF FIGURES .....	xi
LIST OF ABBREVIATIONS AND SYMBOLS .....	xii
CHAPTER ONE.....	1
INTRODUCTION .....	1
1.1 Background of the problem.....	1
1.2 Statement of the problem .....	3
1.3 Rationale of the study .....	4
1.4 Objectives .....	4
1.4.1 General objective .....	4
1.4.2 Specific objectives .....	4
1.5 Research questions.....	4
1.6 Significance of the study.....	4
1.7 Delineation of the study.....	5
CHAPTER TWO .....	6

LITERATURE REVIEW .....	6
2.1 Hydrogen sulfide removal techniques.....	6
2.2 Effect of carbonization temperature on the capacity of activated carbon .....	9
2.3 Effect of activation ratio on adsorption capacity of activated carbon.....	10
2.4 Optimization of removal processes for H <sub>2</sub> S from biogas.....	10
CHAPTER THREE .....	12
MATERIALS AND METHODS.....	12
3.1 Adsorbent preparation.....	12
3.2. Sample characterization .....	12
3.3 Adsorption test.....	12
3.4 Regeneration of the sample.....	14
CHAPTER FOUR.....	15
RESULTS AND DISCUSSION .....	15
4.1 Composition of biogas .....	15
4.2 Samples characterization .....	15
4.3 Hydrogen sulfide removal by the sweet potato leaves AC samples .....	18
4.3.1 Effect of carbonization temperature.....	18
4.3.2 Effect of activation ratio, KOH: C .....	19
4.3.3 Effect of biogas flow rate.....	21
4.3.4 Effect of adsorbent mass .....	21
4.4 Sorption capacity .....	22
CHAPTER FIVE .....	26
CONCLUSION AND RECOMMENDATIONS.....	26
5.1 Conclusion .....	26

5.2 Recommendations.....	27
REFERENCES .....	28
RESEARCH OUTPUT .....	34
Research article.....	34
Poster presentation .....	44

## LIST OF TABLES

Table 1: Performance of different materials and methods for hydrogen sulfide removal from biogas.....	8
Table 2: Composition of biogas .....	15
Table 3: X-ray fluorescence analysis of sweet potato leaves AC .....	15
Table 4: Carbon, Hydrogen, Nitrogen and Sulfur analysis of sweet potato leaves activated carbon.....	16
Table 5: Textural properties of activated fresh and activated spent samples .....	17
Table 6: Summary of the results for sweet potato leaves carbonized sample and activated sample.....	22
Table 7: Comparison of the sweet potato leaves AC with other material. ....	25

## LIST OF FIGURES

Figure 1: Schematic diagram of the adsorption test.....	13
Figure 2: (a) Adsorption – desorption isotherms of the activated carbon (b) Pore size distribution .....	17
Figure 3: Scanning Electron Microscope images of the sweet potato leave AC sample at low-magnification (25.00 KX) and high magnification (50.00 KX): (a, c) fresh AC and (b, d) spent AC samples .....	18
Figure 4: Effect of carbonization temperature on the samples’ adsorption performance: (a) H <sub>2</sub> S concentration after sorption; (b) Removal efficiency. Tests conditions: m = 0.2 g, FR = 0.03 m <sup>3</sup> /h, KOH: C 1:1, C <sub>i</sub> = 1200 – 1290 ppm.....	19
Figure 5: Effect of KOH: C ratio on the samples’ adsorption performance: (a) H <sub>2</sub> S concentration after sorption; (b) Removal efficiency. Test conditions: T <sub>c</sub> = 800 °C, m = 0.3 g, FR = 0.02 m <sup>3</sup> /h, C <sub>i</sub> = 592 ppm.....	20
Figure 6: Effect of biogas flow rate on the samples’ adsorption performance: (a) H <sub>2</sub> S concentration after filter; (b) Removal efficiency. Test conditions: T <sub>c</sub> = 800 °C, m = 0.3 g, KOH: C 1:1, C <sub>i</sub> = 1009 ppm .....	21
Figure 7: Effect of adsorbent mass on the samples’ adsorption performance: (a) H <sub>2</sub> S concentration after sorption; (b) Removal efficiency. Test conditions: T <sub>c</sub> = 800 °C, FR = 0.02 m <sup>3</sup> /h, KOH: C ratio 1:1 C <sub>i</sub> = 591 ppm .....	22
Figure 8: Sweet potato leaves AC performance : (a) H <sub>2</sub> S concentration after sorption; (b) Change in mass of sulfur during sorbent working time. Test conditions: T <sub>c</sub> = 800 °C, FR = 0.02 m <sup>3</sup> /h, m = 1.0 g, KOH: C 1:1, C <sub>i</sub> = 529 ppm .....	23
Figure 9: Comparison between the fresh sample and regenerated sample: (a) H <sub>2</sub> S concentration after sorption by regenerated sample; (b) Change in mass of sulfur during sorbent working time. Test conditions: T <sub>c</sub> = 800 °C, FR = 0.02 m <sup>3</sup> /h, KOH: C 1:1, m = 1.0 g, C <sub>i</sub> = 535 ppm.....	24

## LIST OF ABBREVIATIONS AND SYMBOLS

AC	Activated carbon
AC600	Activated carbon carbonized at 600 °C
AC700	Activated carbon carbonized at 700 °C
AC800	Activated carbon carbonized at 800 °C
BET	Brunauer-Emmett-Teller
BT	Breakthrough time
$C$	Concentration out
C600	Sample carbonized at 600 °C
C700	Sample carbonized at 700 °C
C800	Sample carbonized at 800 °C
CSAC	Coconut shell activated carbon
$C_i$	Concentration in
FR	Flow rate
GHSV	Gas hourly space velocity
Ppm	Part per million
RE	Removal efficiency
SC	Sorption capacity
SEM	Scanning electron microscope
$T_c$	Carbonization temperature
XRF	X-ray fluorescence

# CHAPTER ONE

## INTRODUCTION

### 1.1 Background of the problem

The world is now striving to shift from the use of fossil fuel to renewable energy sources (Florin & Harris, 2008; Niesner, Jecha & Stehlík, 2013), this is the way to get rid of the environmental effects which are brought by the use of fossil fuels. Biogas can act as one option for replacement of fossil fuels among other renewable energy sources like solar, hydro, wind, and tidal energy since during the biogas production the remaining may be used as manure as it contains several nutrients. In addition to that, raw materials for biogas production are locally available.

Biogas is formed through anaerobic microbial decomposition of organic substances which produces not only the potential components, methane ( $\text{CH}_4$ ), but also undesirable impurities such as hydrogen sulfide ( $\text{H}_2\text{S}$ ), carbon dioxide  $\text{CO}_2$  and ammonia ( $\text{NH}_3$ ) to mention but a few (Baena-Moreno, Rodríguez-Galán, Vega, Vilches & Navarrete, 2019). The resulting gas mixture, commonly known as biogas is one of the good alternative energy sources. Unlike fossil fuels, it is renewable, and its production does not cause environmental degradation. Biogas can be used to generate electricity and as a fuel in vehicles to mention but a few.

Hydrogen sulfide contained in biogas gives rise to a variety of problems, including various health problems to human beings depending on the exposure concentration of hydrogen sulfide. Occupational Safety and Health Administration (OSHA) has set an exposure limit of 10-20 ppm for 8 hours in a day. Above this permissive limit exposure to hydrogen sulfide may poison several systems the human body leading to complications such as damaged eyes, lungs problems, headache, anxiety and even death at high concentration of about 1000 ppm. Hydrogen sulfide causes serious environmental concerns such as pollution due to its smell and acidic rain when it is hydrolyzed in the atmosphere (Makauki, King'onde & Kibona, 2017). Acidic rain destructs buildings, alters the soil pH, which is very potential in determining the availability of nutrients in the soil for the betterment of plant growth. It is also damaging plants as well as causing the death of fish by raising the pH in water bodies. Moreover, regarding its corrosive nature, it may cause corrosion of storage tanks, engines and cookers that are using biogas as fuel since it can result to the formation of sulfuric acid by its reaction with water which is contained in biogas (Baena-Moreno *et al.*, 2019). Following the importance of biogas

as a replacement for fossil fuel, it is essential to remove H<sub>2</sub>S before use (Heubeck & Craggs, 2010).

Several methods have been studied for removing hydrogen sulfide from biogas stream. These methods include chemical methods (Peiffer & Gade, 2007; Kanjanarong *et al.*, 2017); biological methods (Gabriel & Deshusses, 2003; Chung, Ho & Tseng, 2007; Pokorna-Krayzelova *et al.*, 2017) and physical methods (Belmabkhout, De Weireld & Sayari, 2009; Makauki *et al.*, 2017). Moreover scrubbing is among the hydrogen sulfide removal methods which employ the use of various scrubbing agents such as water and chemicals. However, a large quantity of scrubbers are required; hence they are expensive. Some scrubbers especially chlorinated chemicals, produces secondary pollutants.

The adsorption method is among the convenient technologies for hydrogen sulfide removal from biogas (Mitomo *et al.*, 2003). To be able to circumvent the challenge of cost, particularly to low-income settings, researchers are focusing on searching for cheap adsorbents using naturally available resources (Ros *et al.*, 2006; Xu, Yang & Spinosa, 2015). The ideal material precursor and the whole production chain of the adsorbent should be environmentally friendly. Various studies have reported several adsorbents for hydrogen sulfide adsorption. Kandola *et al.* (2018) reported hydrogen sulfide removal using Oldoinyo Lengai volcanic ash with sorption capacity of up to 1 g S/100 g of Oldoinyo Lengai volcanic ash. The potency of the Oldoinyo Lengai volcanic ashes on the removal of hydrogen sulfide from biogas stream can only be exploited at the expense of environment; as it is a non-renewable resource that, if mined, will lead to the destruction of the Oldoinyo Lengai conservation area. Zeolite is efficient hydrogen removing material as it was reported by Sigot, Ducom and Germain (2016). However, its mining causes environmental degradation, it is not renewable and is not abundantly locally available.

Activated carbon is amongst the adsorbent for hydrogen sulfide removal from biogas following its surface properties which make it efficient in the adsorption process. In a recent study, Makauki *et al.* (2017) prepared activated carbon from water hyacinths which achieved up to 93% hydrogen sulfide removal efficiency. However, the use of the precursor has the potential of promoting water hyacinths cultivation which may lead to invading and dominating more water bodies. Coconut shell activated carbon is another adsorbent material which has been reported by Choo, Lau, Mohamed and Lee (2013); however, it is not abundantly locally



available material. The weaknesses of various materials in biogas purification call for continued effort to search for better materials.

Sweet potatoes have been reported to have iron content, especially in leaves; however, other metals like Mg, Al, K, P and Ca are also contained in sweet potato plant (Ishida *et al.*, 2000; Amagloh, Atuna, McBride, Carey & Christides, 2017). The plant grows fast and is abundantly available. The leaves of plants can act as precursor materials for porous activated carbon that is rich in iron which has been reported to have a significant removal capacity (Al-Imarah, Lafta, Jabr & Mohammad, 2017). The fact that sweet potato plants grow fast and contain iron, that could facilitate H<sub>2</sub>S removal, as well as the absence of information about the preparation of activated carbon using sweet potato leaves as an adsorbent to remove H<sub>2</sub>S from biogas, motivated the choice of the plant as a novel precursor for preparation of adsorbent material. It is anticipated that, due to the iron content, the performance of the material might be raised. The adsorptive porous activated carbon provides ample surface area while iron oxide facilitates chemisorption leading to enhanced performance. Besides, use of the plant will promote its cultivation leading to consolidated food security as the tubers will be used as food.

This study aimed to investigate the sorption performance of sweet potato leaves derived activated carbon on the removal of hydrogen sulfide from biogas.

## **1.2 Statement of the problem**

Hydrogen sulfide, which is both poisonous and corrosive is among the challenging impurities in biogas. Many materials for hydrogen sulfide removal from biogas, at the household level and small scale biogas production plants, have been reported. However, these materials suffer from one or more of the following drawbacks; low efficiency, unavailability and inaccessibility, environmental unfriendliness and low adsorption capacity. This signifies the need to search for new readily available alternative materials to produce affordable and efficient filters. In this study, sweet potato leaves have been used as a precursor to derive activated carbon for H<sub>2</sub>S removal from biogas. The precursor is available and renewable material that contain iron oxide. Both activated carbon and iron oxide are potential H<sub>2</sub>S adsorbent materials. Besides, sweet potatoes can grow in a short time. Its cultivation results in food production; and the leaves may cater for both activated carbon as well as biogas production. Furthermore, to the best of my knowledge, the use of activated carbon (AC) prepared from sweet potato leaves through chemical activation has not been reported.

### **1.3 Rationale of the study**

Hydrogen sulfide contained in biogas can cause different health problems once inhaled by human beings due to its poisonous nature; it can even cause death when inhaled at high concentrations. It is also corrosive gas due to its acidic nature. It is important to develop materials to remove hydrogen sulfide to get rid of the problems which may be caused by hydrogen sulfide. Thus, using sweet potato leaves activated carbon adds an alternative to the current materials which may be accessible and affordable to local communities.

### **1.4 Objectives**

#### **1.4.1 General objective**

To investigate the potential of sweet potato leaves derived activated carbons as an adsorbent for H<sub>2</sub>S removal from biogas.

#### **1.4.2 Specific objectives**

- (i) To analyze the textural properties and chemical composition of the samples.
- (ii) To assess the performance of the samples in the H<sub>2</sub>S removal from biogas.
- (iii) To determine the regenerative ability of the material.

### **1.5 Research questions**

- (i) What are the chemical composition and surface characteristics (porosity, morphology, surface area) of the samples?
- (ii) What is the H<sub>2</sub>S removal capacity of the samples?
- (iii) What is the regenerative ability of the material?

### **1.6 Significance of the study**

This study aims at developing materials which will then be applied in biogas plants to clean the biogas. Cleaning biogas leads to a protected environment as well as preventing health complications which could be brought by using biogas which is not clean. Moreover, the introduction of sweet potato leaves as precursor for activated carbon for adsorption of hydrogen

sulfide can be a replacement to other precursors. Furthermore, sweet potato leaves will add more options to other current materials since they can grow very fast within a short time.

### **1.7 Delineation of the study**

Delineation of this study is based on biogas cleaning to remove hydrogen sulfide using activated carbon which was prepared through chemical activation. Activation was done at 800 °C for one hour. Before activation, the materials were carbonized with carbonization temperature ranging from 600-800 °C. The adsorption tests were done on-site at household biogas plant where biogas is produced using kitchen and garden remaining with the addition of chicken manure. Biogas concentration was analyzed before and after adsorption to study the effect of an adsorbent.

## CHAPTER TWO

### LITERATURE REVIEW

#### 2.1 Hydrogen sulfide removal techniques

Various methods have been used to remove hydrogen sulfide from biogas. These methods can be subdivided into physical, chemical and biological methods.

Physical methods such as membrane technology are not cost-effective since this method require regular replacement of material (Chung *et al.*, 2007). Adsorption by activated carbon derived from water hyacinth was reported to have removal efficiency (RE) of 93% at 0.024 m<sup>3</sup>/h flow rate (Makauki *et al.*, 2017). The use of water hyacinth is beneficial due to its problems in water bodies such as a reduced amount of oxygen in water leading to suffocation and death of fish and other aquatic organisms. Adsorption by activated carbon from coconut shell was reported to possess 2.03 g S/100 g AC (Choo *et al.*, 2013). In addition to that, adsorption by volcanic ash showed good performance of about 1 g S/100 g of ash sorption capacity.

Chemical methods include; oxidation by chelates, e.g. Fe- EDTA, which showed 99% efficiency of removing hydrogen sulfide (Maia *et al.*, 2017). Oxidation by zeolite was reported to have high efficiency at the dry condition (Sigot *et al.*, 2016). In addition to that, oxidation by ZnO showed removal efficiency of 76% (Garces, Espinal & Suib, 2012).

Biological methods which employ the use of microorganisms have been reported to have an efficiency greater than 98% (Huang & Ko, 2015). However, biological methods are very slow and sensitive to temperature.

The adsorption process is widely used technology for different applications including removing H<sub>2</sub>S contained in biogas (Mitomo *et al.*, 2003). Hydrogen sulfide removal by adsorption is a promising technique which has shown high efficiency in the overall process of biogas purification. To be able to circumvent the challenge of being too costly and inaccessible, particularly to low-income settings, researchers are focusing on searching for cheap adsorbents using naturally available material (Ros *et al.*, 2006; Xu *et al.*, 2015). The ideal material precursor and the whole production chain of the adsorbent need to be environmentally friendly. Table 1 summarizes the weaknesses of various adsorbent materials found in literature. These

drawbacks, as depicted in Table 1, signify the need for continued effort to search for better materials that are not only efficient but also accessible to low-income communities.

Activated carbons are suitable adsorbents owing to their high surface area, porosity and a high degree of surface reactivity. The surface area depends on the type of pores available. Adsorbent pores are categorized into three classes according to IUPAC: micropores size (<2 nm), mesopores (2-50 nm) and macropores (>50 nm). The surface area has a significant impact on adsorption efficiency. Therefore activated carbons can be used to clean biogas (Kaneko, Ishii & Ruike, 1992). Following the properties of activated carbon, adsorption using activated carbon has been studied by many scholars. As it has been pointed out earlier a good number of carbon precursors have been used as a source of activated carbon. However, activated carbon has been very expensive since materials which usually are used as precursors including coal and wood are expensive (Ma *et al.*, 2017); therefore the use of biomass is drawing attention since it is cheap and readily available.

Activated carbon can be derived from numerous biomass materials, including agricultural residuals. Being inexpensive materials, agricultural wastes have been used to develop relatively cheap carbon materials. Some of the agricultural wastes include: lignin (Hayashi, Kazehaya, Muroyama & Watkinson, 2000), coconut husk (Tan, Ahmad & Hameed, 2008), bituminous coal (Teng, Yeh & Hsu, 1998), water hyacinth (Huang, Li, Chen, Zhang & Chen, 2014) and fish bladder (Karuga, Jande, Kim & King'ondeu, 2016). However, these precursor materials suffer one or more of the following drawbacks; low efficiency, unavailability and inaccessible, environmentally unfriendly and slow adsorption kinetics. The use of chemical methods to remove H<sub>2</sub>S from biogas requires the frequent addition of chemicals which are costly, unhealthy and lead to secondary wastes. This signifies the need to search for new readily available alternative materials to produce affordable and efficient filters.

Sweet potato leaves grow fast and are abundantly available. Besides the leaves contain iron (Nozoye *et al.*, 2017) thus, they can act as precursor materials for porous activated carbon. Iron (III) oxide has been reported to have H<sub>2</sub>S removal capacity of about 0.64 kg S/ kg Fe<sub>2</sub>O<sub>3</sub> (Al-Imarah *et al.*, 2017). Since activated carbon derived from sweet potato leaves contain iron oxides, including Fe<sub>2</sub>O<sub>3</sub>, it might have reasonable H<sub>2</sub>S removal efficiency. The adsorptive porous activated carbon provides ample surface area while iron oxide facilitates adsorption leading to enhanced performance

**Table 1: Performance of different materials and methods for hydrogen sulfide removal from biogas**

Material	Mechanism	Efficiency	Weakness	Reference
<b>Chemical method</b>				
Scrubbers	Water scrubbing or chemicals scrubbers.	Efficient up to 99%.	A large amount of scrubber is needed, and thus it is not cost-effective. Chemical scrubbers lead to Secondary pollutants.	Lien, Lin and Ting (2014)
Chelates-Eg Fe-EDTA	Oxidation	99%	Costly since it requires frequent replacement, not abundantly locally available.	Maia <i>et al.</i> (2017)
Zeolite	Oxidation	High at the dry condition.	Not abundantly locally available. Its mining leads to environmental degradation.	Sigot <i>et al.</i> (2016)
Zinc oxide	Oxidation	76%	Water sensitive; water vapour in the biogas favours the backward reaction.	Garces <i>et al.</i> (2012)
<b>Biological method</b>				
Microorganisms Eg. sulphur oxidizing bacteria	Oxidation	Greater than 98%.	The process is very slow, sensitive to temperature, and need time to stabilize.	Ramírez, Zarate, Guerrero and Garcia (2009)
<b>Physical method</b>				
Activated carbon from water hyacinth	Physisorption	93% at 0.024 m <sup>3</sup> /h flow rate.	It is not abundantly locally available. Potential to spread the invasive plant	Makauki <i>et al.</i> (2017)
Activated carbon from coconut shell	Physisorption	2.03 g S/100 g of AC.	It is not abundantly locally available.	Choo <i>et al.</i> (2013)
Volcanic ash	Chemisorption	1 g S/100 g of ash.	A non-renewable resource that, if mined, will lead to the destruction of the conservation area.	Kandola <i>et al.</i> (2018)

## 2.2 Effect of carbonization temperature on the capacity of activated carbon

The adsorption capacity of activated carbon is profoundly affected by carbonization temperature, which is highly influencing the amount of micropores present in the solid. Carbonization process is quite significant in creating initial porosity in the char. The higher the carbonization temperature, the higher the production of micropores hence the production of carbon with high porosity. However this is just creation of initial porosity which will be further developed after activation which creates the modified structure to form highly porous solid; thereby increasing surface area and total pore volume of the produced activated carbon (Ma *et al.*, 2017).

Carbonization temperature ranges between 500 – 900 °C. The quality of activated carbon depends mainly on the carbonization temperature. Over this range of carbonization temperature, the sample prepared from high-temperature chars has been reported to have more significant absolute micropore volumes. At high carbonization temperature, a more ordered structure is formed in the char resulting in the production of highly microporous activated carbon. Production of activated carbon with high micropore volume depends strongly on carbonization temperature, which results in the production of activated carbon with high Brunauer-Emmett-Teller (BET) surface area, total volume and micropore volume. It has been found that the development of both mesopore and macropore is not affected by carbonization temperature (Daud, Ali & Sulaiman, 2000). However in the study done by Hayashi *et al.* (2000), it has been found that by the use of alkali activation specific surface area increases with increase in carbonization temperature up to 800 °C above which pores combine to produce mesopores due to excess expansion of the pores, micropore volume is decreased and as a result surface area decreases. Besides, according to the same paper, with the use of alkali as activating agent surface area of activated carbons prepared at 500 °C is smaller than the activated carbon prepared by ZnCl<sub>2</sub> and H<sub>3</sub>PO<sub>4</sub> at the same temperature. Therefore, alkali activation works best at a higher temperature from 500 °C up to 800 °C where surface area increases concurrently, after that it decreases from 800 °C to 900 °C (Hayashi *et al.*, 2000).

In general, carbonization temperature has been found to strongly affect the production of micropores which are very significant in the overall process of adsorption by activated carbon to be produced. Adsorption capacity increases with an increase in carbonization temperature.

### **2.3 Effect of activation ratio on adsorption capacity of activated carbon**

Activated carbons have variety of function regarding their properties, including surface area and specific surface characteristics, thus having diverse applications. Currently, researchers are striving to look for low-cost precursor materials for the preparation of activated carbon. Activated carbon can be prepared either by a physical or chemical method whereby chemical activation is significantly preferred rather than physical activation due to its properties. Chemical activation can be accomplished at a lower temperature, and the activated carbon yield is higher compared to physical activation. However, the best performance of activated carbon depends basically on different preparation conditions; one of these conditions is the activation ratio when using chemical activation (Uner & Bayrak, 2018).

Activation ratio is having a significant effect on the type of pores to be produced. Production of micropores increases with an increase in activation ratio. Nevertheless, at higher activation ratio micropores are being widened to mesopores, thereby causing a decrease in surface area of the carbon to be produced hence lower adsorption capacity. In addition to that, the higher activation ratio leads to a decrease in the yield of activated carbon (Sudaryanto, Hartono, Irawaty, Hindarso & Ismadji, 2006).

### **2.4 Optimization of removal processes for H<sub>2</sub>S from biogas**

There are different microelements contained in sweet potato leaves; however, iron seems to be the most abundant microelement (Sun, Mu, Xi, Zhang & Chen, 2014). Sweet potato leaves have a higher content of iron in compared to other vegetables (Ishida *et al.*, 2000).

Purification of biogas leads to its high utilization since biogas is an alternative source of energy in many countries. However, the purifying is expensive. It is therefore compulsory to have optimized purification process in terms of low energy expenditure as well as high efficiency giving high methane content in purified gas. Dry processes have an excellent performance for H<sub>2</sub>S removal. With these processes, there is an interaction between the solid material and the gas stream whereby various reactions can take place according to the properties of the solid material. Dry desulphurization does not create liquid waste (van Rheinberg, Lucka, Köhne, Schade & Andersson, 2008).

This study aims at investigating the use of sweet potato leaves as a supplier of not only activated carbon but also iron for H<sub>2</sub>S removal from biogas. The adsorption process was done by



evaluating carbonuzation temperature, flow rate, the concentration (mass) of adsorbent and activation ratio to get optimal conditions for efficient adsorption process.

## CHAPTER THREE

### MATERIALS AND METHODS

#### 3.1 Adsorbent preparation

Sweet potato leaves were dried using an oven at 100 °C, then powdered, sieved and carbonized in a furnace at 600 °C, 700 °C and 800 °C for 1h under a constant flow of nitrogen gas to ensure an inert atmosphere. Carbonization was followed by activation with potassium hydroxide as activating agent. Activation was done by using a fixed mass of carbon which was mixed with a different mass of KOH in 50 ml of distilled water each time to obtain 1:1, 1:2, 1:4 KOH: C ratio. A magnetic stirrer was then used to stir the mixture at 80 °C for half an hour. The obtained homogeneous mixture was put in an oven to dry at 100 °C before being placed in a tube furnace to be activated at 800 °C for 1h under inert condition. Both carbonization and activation were performed at a heating rate of 10 °C/min. Activation was followed by washing with 50 ml of dilute HCl and distilled water up to neutral pH was obtained, then the samples were dried for 12 h using an oven at 100 °C. After drying, the samples were stored for H<sub>2</sub>S removal test. The carbonized samples were labelled (C600, C700, C800), and from each carbonized sample, three activated samples with ratio, 1:1, 1:2, 1:4 KOH: C were obtained. These are AC600, AC700, and AC800 for each carbonized sample to make a total of nine samples.

#### 3.2. Sample characterization

Carbonized, activated fresh and activated spent samples were characterized by BET analysis using Quanta Chrome Nova 4200 (Win © 1994-2013, VII.03) with Nitrogen adsorption-desorption isotherm to measure pore structural properties. Elemental analysis was performed using Energy Dispersive X-ray Fluorescence ED-XRF, and CHNS analyser was used to confirm the presence of carbon. The surface morphology of the samples was analyzed by Zeiss Ultra plus Field Emission Scanning Electron Microscopy FE SEM (Biocompare South San Francisco, CA 84080 USA).

#### 3.3 Adsorption test

The hydrogen sulfide adsorption experiments were done at the household biogas plant. The setup of the experiment is shown in Fig. 1. The valve was used to obtain the desired flow rate (FR) whereby biogas flowed through an inlet of gas flow rate meter and through the outlet

where the bed reactor tube with sample activated carbon-supported by cotton wool was connected. The bed reactor tube was connected to the biogas analyser, which analysed the biogas components. Before joining the bed reactor tube with the sample, the biogas itself was analysed to record the initial concentration, especially the concentration of H<sub>2</sub>S.

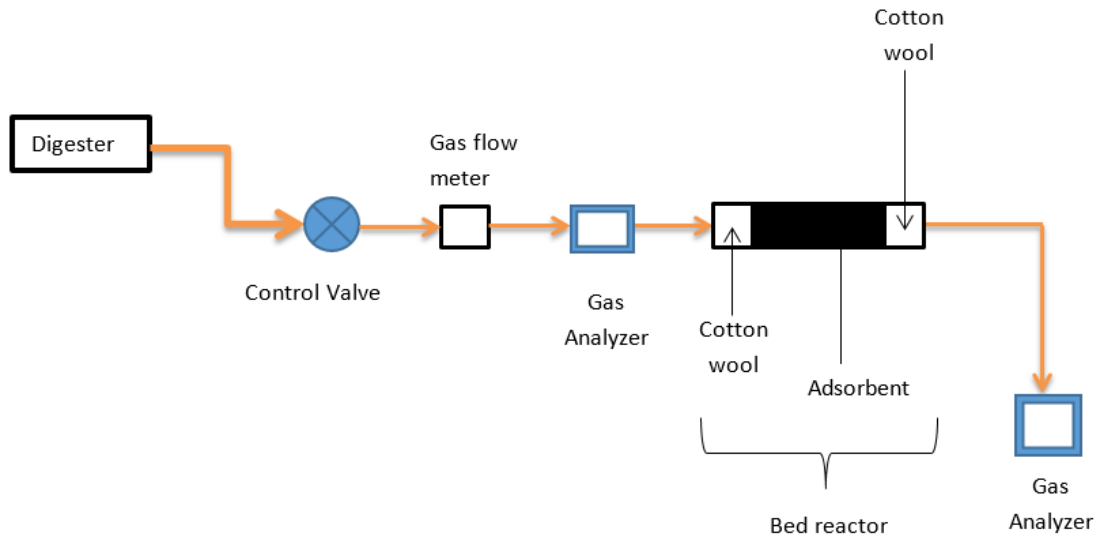

**Figure 1: Schematic diagram of the adsorption test**

Removal efficiency (RE) was calculated using equation (1).

$$RE = \frac{C_i - C}{C_i} \times 100\% \quad (1)$$

Where  $C_i$  and  $C$  are the initial and final concentration of H<sub>2</sub>S. Sorption capacity (SC) of a sorbent is the amount of sorbate taken up by the sorbent per unit mass (or volume) of the sorbent. Sorption capacity was calculated using equation (2) (Kandola, Pogrebnoi & Pogrebnaya, 2018).

$$SC = GHSV \times \frac{M}{V_{mol}} \left[ \int_0^t (C_i - C) dt \right] \quad (2)$$

where GHSV is gas hourly space velocity in Lh<sup>-1</sup>g<sup>-1</sup>,  $M$  is the molar mass of sulphur,  $V_{mol}$  is the molar volume of gas in dm<sup>3</sup>mol<sup>-1</sup>,  $dt$  is the time interval,  $t$  is the breakthrough time (BT) in h at which H<sub>2</sub>S concentration drops to half of the initial concentration.

Change in mass of sulfur adsorbed every  $\Delta t = 10$  min. was calculated by equation (3).

$$\Delta m = GHSV \frac{M}{V_{\text{mol}}} (C_i - C) \Delta t \quad (3)$$

Where,  $\Delta m$  is change in mass of sulfur adsorbed during sorbent working time.

### **3.4 Regeneration of the sample**

Spent activated carbon (AC) is usually regenerated and being reused to avoid disposal cost. The regenerated carbon is disposed after it has been reused several times while without regeneration, the carbon is used only once before being disposed. In this study, the saturated sample was regenerated through a thermal process under the flow of nitrogen gas in the furnace at 220 °C for 30 min. After regeneration, the sample was inserted into the bed reactor tube and being tested for adsorption. This method was also used in another study whereby spent activated carbon was heated in a tube furnace in presence inert gas at 220 °C for 30 min. (Gebreegziabher, Wang & Nam, 2019). The inert gas is important to use to prevent burning of activated carbon.

## CHAPTER FOUR

### RESULTS AND DISCUSSION

#### 4.1 Composition of biogas

The plant is having two digesters, digester 1 and digester 2, producing biogas composed of methane, carbon dioxide, ammonia and hydrogen sulfide as shown in Table 2, whereby the amount of constituents depends on the feedstock used in a particular day. The changes in concentration of H<sub>2</sub>S before sorption was also monitored during sorbent working time and showed no changes in the initial concentration of H<sub>2</sub>S. That means a constant initial H<sub>2</sub>S concentration during sample testing.

**Table 2: Composition of biogas**

Constituents	Biogas digester 1	Biogas digester 2
CH <sub>4</sub>	66 – 68%	60 -72%
CO <sub>2</sub>	35 – 37%	30 – 41%
H <sub>2</sub> S	500 – 592 ppm	800 – 1292 ppm
NH <sub>3</sub>	10 – 18 ppm	17 – 24 ppm

#### 4.2 Samples characterization

X-ray fluorescence (XRF) analysis for the sweet potato leaves AC sample prepared at  $T_c$ , 800 °C and KOH: C, 1:1 showed the presence of iron Table 3, which is expected to influence the adsorption of hydrogen sulfide through oxidation reaction with H<sub>2</sub>S. The Fe<sub>2</sub>O<sub>3</sub> has been reported to be most viable than other components which are not much responsible for H<sub>2</sub>S removal at room temperature; however, they may be viable for removing other impurities, for instance, MgO has been reported to remove CO<sub>2</sub> from biogas (Żarczyński, Rosiak, Anielak & Wolf, 2014).

**Table 3: X-ray fluorescence analysis of sweet potato leaves AC**

Mineral	Na <sub>2</sub> O	MgO	Al <sub>2</sub> O <sub>3</sub>	SiO <sub>2</sub>	P <sub>2</sub> O <sub>5</sub>	Fe <sub>2</sub> O <sub>3</sub>
Conc. in ppm	5800	34500	5900	34900	24400	5000

Presence of carbon was confirmed through CHNS analysis, as shown in Table 4. This additional CHNS test was done due to the reason that the X-ray fluorescence machine used (Energy Dispersive X-ray Fluorescence - ED-XRF) started detecting chemical elements since number eleven, which is sodium.

**Table 4: Carbon, Hydrogen, Nitrogen and Sulfur analysis of sweet potato leaves activated carbon**

Elements	C	N	H	S
Wt%	56.25	1.53	2.00	0.00

Micropores available and surface area are vastly responsible for the adsorption performance of AC. Figure 2(a) displays N<sub>2</sub> adsorption-desorption isotherm for two samples, fresh and spent sweet potato leaves AC and Fig. 2(b) displays pore size distribution, calculated by the method known as BJH. As is seen, fresh activated carbon had highest N<sub>2</sub> adsorption capacity, which is apparently contributed by the highest BET surface area. The volume of N<sub>2</sub> adsorbed by fresh activated carbon is higher than that adsorbed by a spent sample.

Textural properties, BET surface area, pore volume and pore diameter, of the carbonized sample, fresh sweet potato leaves AC with 1:1 KOH: C, as well as spent AC which undergone the H<sub>2</sub>S sorption, are shown in Table 5. These results show that sweet potato leaves AC has a higher surface area than the carbonized (C) sample. Activation leads to an increase in surface area and pore volume. Apparently adsorption process leads to decreased surface area and pore volume. Similar results, as shown in Table 5, have been reported for coconut shell activated carbon (CSAC) (Choo *et al.*, 2013). Therefore activation process enhances high porosity of the produced activated carbon, resulting in high ability to remove H<sub>2</sub>S through adsorption. Furthermore, sweet potato leaves AC produced seems to be typical mesopore carbon by having more pores distributed between 3 - 30 nm, as shown in Fig. 2(b) which indicates that fresh activated sample exhibits higher differential volume than spent activated sample, this is in accordance to their surface area. However, as it is indicated in Table 6, the BET surface area is contributed by both the mesopore and micropore area. Therefore sweet potato leaves AC is a source of mesoporous adsorbent with certain amount of micropores. We suggest micropores would be more pronounced at higher KOH: C ratio than 1:1 that has been used as a maximum ratio in this study. Similar results may be observed in another study whereby, tomato waste was used as a precursor to produce mesoporous AC by chemical activation (Saygılı & Güzel,

2016).

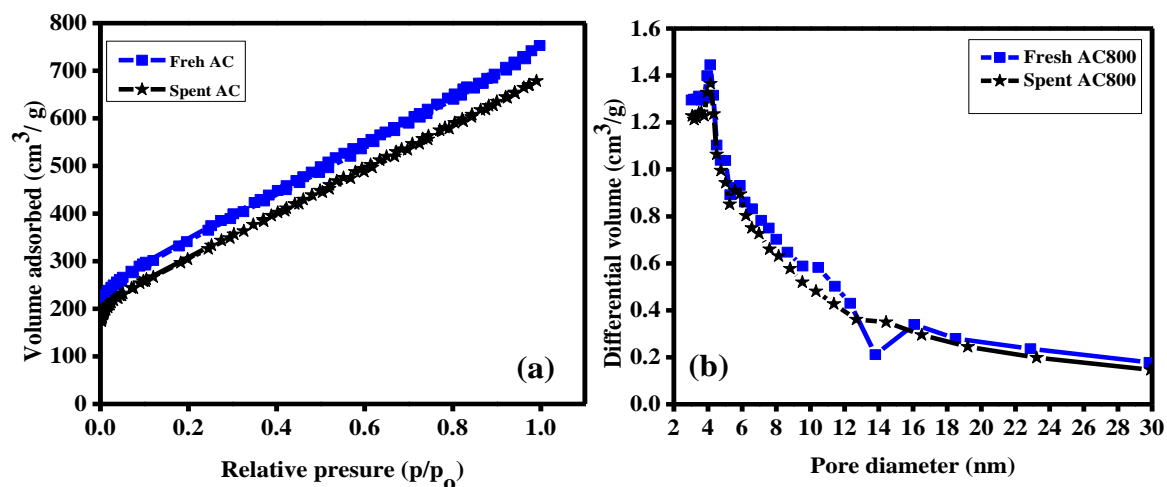
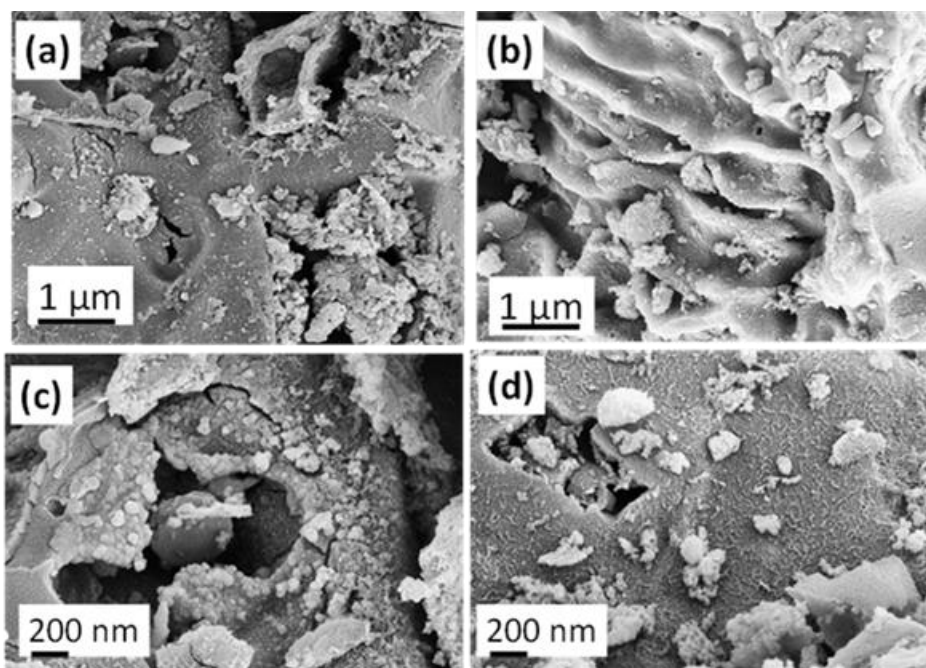

**Figure 2: (a) Adsorption – desorption isotherms of the activated carbon and (b) Pore size distribution**

**Table 5: Textural properties of activated fresh and activated spent samples**

Sample	BET surface area (m <sup>2</sup> /g)	Pore volume (cm <sup>3</sup> /g)	Pore diameter (Å)	References
C	637	0.568	30.3	This study
Fresh AC800	1220	0.732	30.8	This study
Spent AC800	1096	0.666	30.4	This study
Fresh CSAC	726.2	0.4	20.5	Choo <i>et al.</i> (2013)
Spent CSAC	607.4	0.3	20.0	Choo <i>et al.</i> (2013)

The SEM analysis was engaged to study the surface morphology of freshly prepared and spent AC, as shown in Fig. 3. Both samples were prepared at 1:1 KOH: C ratio, which is the highest ratio in this study. Considerable differences may be observed between fresh prepared and spent AC. There are spherical shaped particles on the surface of spent activated carbon. This difference might be caused by adsorption of H<sub>2</sub>S on the pores of AC which accords well with higher surface area, and pore size of fresh sweet potato leaves AC as presented in Table 5. The mesopores and micropores were created in AC as a result of KOH evaporation during the activation step.



**Figure 3: Scanning Electron Microscope images of the sweet potato leave AC sample at low-magnification (25.00 KX) and high magnification (50.00 KX): (a, c) fresh AC and (b, d) spent AC samples**

### **4.3 Hydrogen sulfide removal by the sweet potato leaves AC samples**

Performances of adsorbent samples have been analyzed and shown using a graph of H<sub>2</sub>S concentration after sorption and RE against sorbent working time; the effect of different factors are analyzed.

#### **4.3.1 Effect of carbonization temperature**

Sweet potato leaves derived carbon was carbonized at different temperatures, between 600-800 °C. Effect of carbonization temperature on hydrogen sulfide removal by samples was considered; the H<sub>2</sub>S concentration after sorption was monitored, the readings were taken every 10 min. during test up to approaching sample saturation. Results are displayed both for carbonized samples (C800) and activated samples (AC800) in Fig. 4.



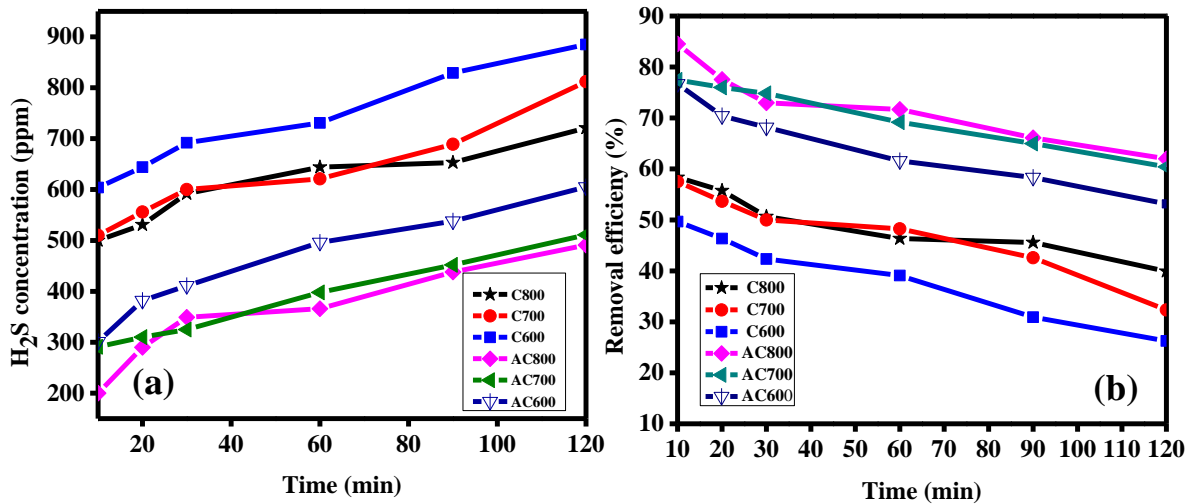

**Figure 4: Effect of carbonization temperature on the samples' adsorption performance: (a) H<sub>2</sub>S concentration after sorption; (b) Removal efficiency. Tests conditions:  $m = 0.2 \text{ g}$ ,  $FR = 0.03 \text{ m}^3/\text{h}$ ,  $KOH: C \text{ 1:1}$ ,  $C_i = 1200 - 1290 \text{ ppm}$**

Adsorption capacity increases with the increase in carbonization temperature. Sample which was carbonized at high temperature has been found to have higher adsorption capacity, for both C and AC. The adsorption capacity of activated carbon could be profoundly affected by carbonization temperature, which creates initial porosity in the char. The higher the carbonization temperature, the higher the production of porosity. Adsorption capacity increases with an increase in carbonization temperature, however, activated samples have higher RE than that of carbonized samples, and this shows the significance of activation process in the development of pores essential for adsorption. These results are similar to the previous study which aimed at preparing AC by chemical activation whereby chemical activation with alkali metals has been found to work best at carbonization temperature between 500 – 900 °C (Hayashi *et al.*, 2000). At carbonization temperature between 500-900 °C surface area increases concurrently, however, it will decrease from 800 °C to 900 °C since at higher temperature above 800 °C pores combine to produce mesopores. Therefore, the optimal carbonization temperature for sweet potato leaves derived activated carbon with KOH activating agent is 800 °C.

#### 4.3.2 Effect of activation ratio, KOH: C

Type of the pores to be produced depends on different activation condition whereby activation ratio is very considerable for micropores production when chemical activation is used (Üner &

Bayrak, 2018). Figure 5 displays the effect of KOH: C ratio on removal efficiency of sweet potato leaves AC, whereby three activated carbon samples with different activation ratios were studied. According to results, removal efficiency increases with an increase in activation ratio.

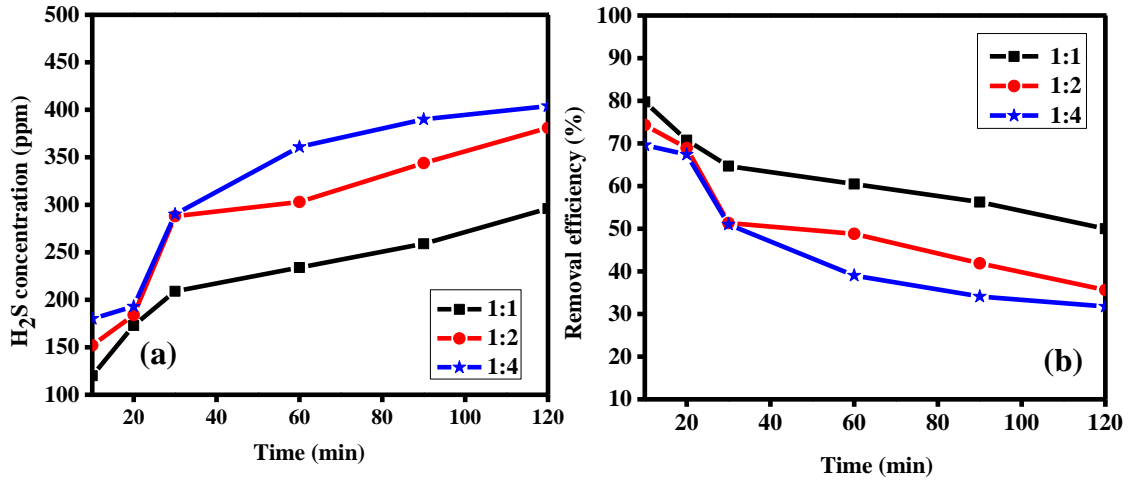
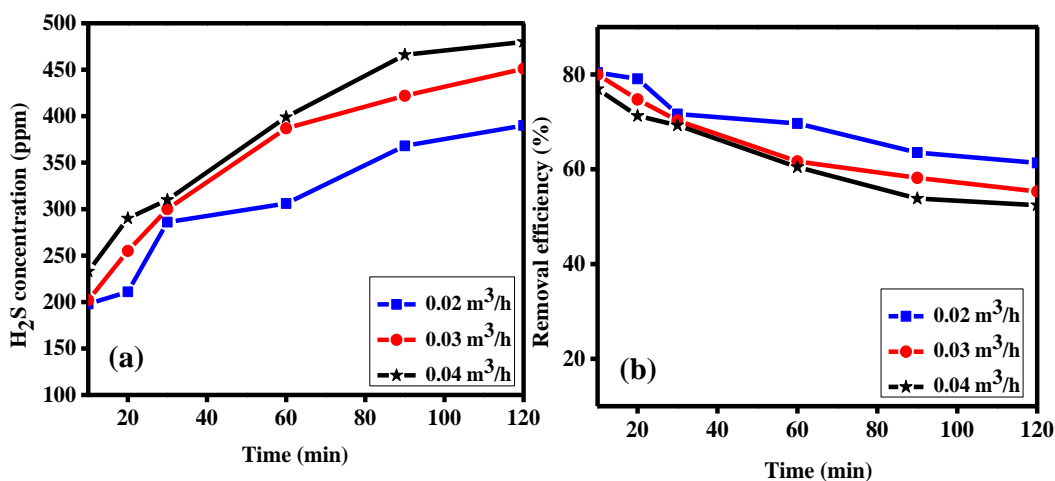

**Figure 5: Effect of KOH: C ratio on the samples' adsorption performance: (a) H<sub>2</sub>S concentration after sorption; (b) Removal efficiency. Test conditions:  $T_c = 800$  °C,  $m = 0.3$  g,  $FR = 0.02$  m<sup>3</sup>/h,  $C_i = 592$  ppm**

After initial pores have been developed through carbonization, activation enhances further development of pores and produces an ordering of the structure to come up with highly porous activated carbon for improved performance on the adsorption process. Production of micropores increases with an increase in activation ratio. However, when the amount of activation ratio is very high, the yield of activated carbon is decreased, causing lowered adsorption capacity (Wei, Li & Gao, 2016). According to this study, as it is shown in Fig. 5b, the activated carbon with the highest ratio has the highest removal efficiency compared to others. Therefore, it seems that AC with 1:1 KOH: C has higher amount of micropores than others. When KOH: C ratio is raised, sweet potato leaves AC is expected to have a higher surface area as shown in the results as reported in a recent study (Wei *et al.*, 2016). In this study, the highest activation ratio is 1:1, KOH: C, which could be raised to obtain more microporous AC leading to the higher sorption capacity.

### 4.3.3 Effect of biogas flow rate

Gas flow rate is a potential factor to consider during adsorption experiment as it is among the factors that facilitate the overall process to come up with efficient adsorption. Figure 6 shows the effect of flow rate on the performance of sweet potato leaves AC.

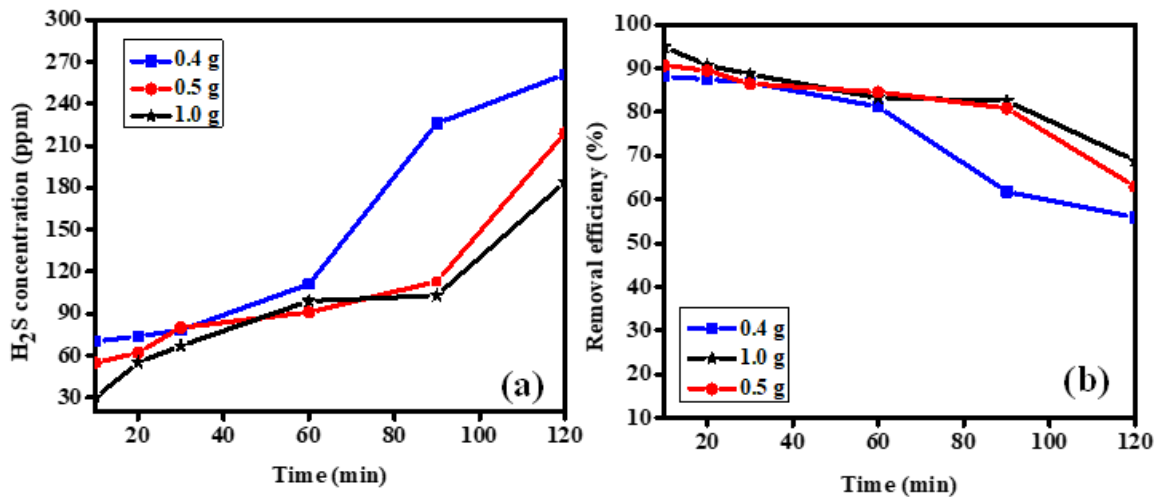

**Figure 6: Effect of biogas flow rate on the samples' adsorption performance: (a) H<sub>2</sub>S concentration after filter; (b) Removal efficiency. Test conditions: T<sub>c</sub> = 800 °C, m = 0.3 g, KOH: C 1:1, C<sub>i</sub> = 1009 ppm**

According to Fig. 6b, it has been found that the RE of activated carbon is high at the lowest flow rate of biogas and low at the highest flow rate of biogas. The results are apparently due to the reason that flow rate determines the time by which H<sub>2</sub>S contact with sorbent material. At lower flow rate the contact time between H<sub>2</sub>S and adsorbent is increased hence increasing the chance of all H<sub>2</sub>S molecules to be adsorbed from a gas stream until it reaches saturation point leading to higher adsorption capacity. In this study, the highest activation ratio is 1:1, KOH: C, which could be raised to obtain more microporous AC leading to the higher sorption capacity.

### 4.3.4 Effect of adsorbent mass

Activation of carbon enhances the development of micropores leading to a large surface area for adsorption. The likelihood of H<sub>2</sub>S to contact with adsorption sites on activated carbon surface increases with the increase in the amount of adsorbent. Figure 7 is displaying the effect of adsorbent mass on the performance of sweet potato leaves AC. As it is shown in the Fig. 7, higher RE was increasing with an increase in sorbent mass.



**Figure 7: Effect of adsorbent mass on the samples' adsorption performance: (a) H<sub>2</sub>S concentration after sorption; (b) Removal efficiency. Test conditions: T<sub>c</sub> = 800 °C, FR = 0.02 m<sup>3</sup>/h, KOH: C ratio 1:1, C<sub>i</sub> = 591 ppm**

These results could be influenced by a higher amount of activated carbon that enhances larger contact surface area for H<sub>2</sub>S to be held into the pores of adsorbent hence higher RE. However, in this study the mass of adsorbent used depended much on the set up of experiment which allowed just small mass of sample to be inserted into the bed reactor. Therefore the highest mass used in this study was 1.0 g which exhibited the highest removal efficiency as it is shown in subsection 4.1.4. Therefore the optimal mass of adsorbent to be used depends on the size of the bed reactor tube, which is used and the overall set up of the experiment.

#### 4.4 Sorption capacity

Sorption capacity in a gram of hydrogen sulfide per 100-gram adsorbent for both carbonized and activated samples was calculated using Eq. (2). According to results as it is shown in Table 6, the SC of activated carbon exhibited higher SC compared to the carbonized sample. This is probably since AC is more porous than the C sample.

**Table 6: Summary of the results for sweet potato leaves carbonized sample and activated sample**

Sample	S <sub>BET</sub> m <sup>2</sup> /g	d Å	BT min.	RE %	SC g/100 g	Micropore area (m <sup>2</sup> /g)	Mesopore area (m <sup>2</sup> /g)
C800	637	30.3	30	58	0.7	157	480
AC800	1220	30.8	170	95	1.9	597	623

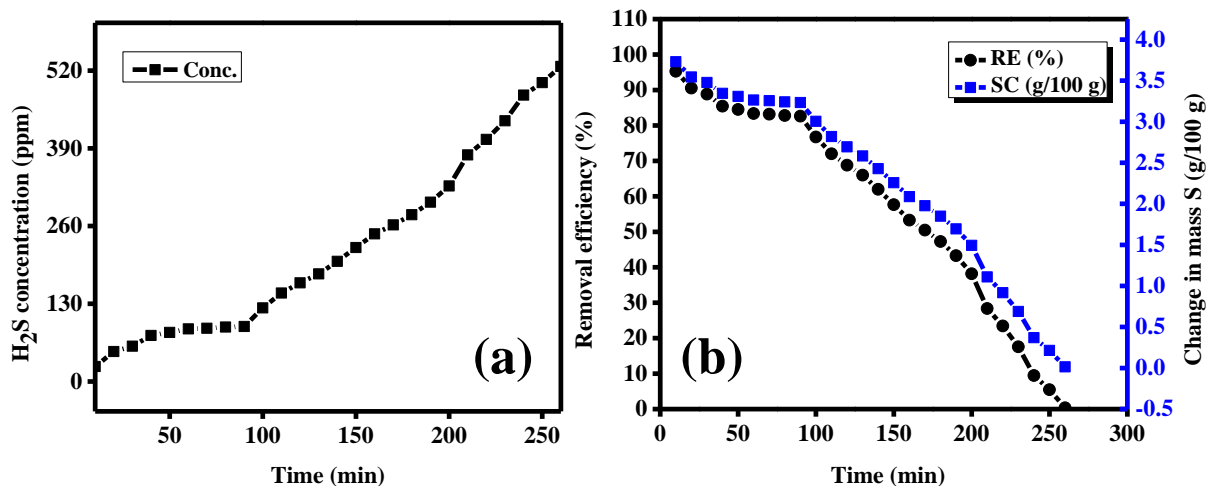

**Figure 8: Sweet potato leaves AC performance: (a) H<sub>2</sub>S concentration after sorption; (b) Change in mass of sulfur during sorbent working time. Test conditions: T<sub>c</sub> = 800 °C, FR = 0.02 m<sup>3</sup>/h, m = 1.0 g, KOH: C 1:1, C<sub>i</sub> = 529 ppm**

Sorption performance of the best sample AC800 is displayed in Fig. 8. From the H<sub>2</sub>S concentration measurements, change in mass of sulfur adsorbed every  $\Delta t = 10$  min. was calculated by equation 3. As is seen the amount of sulfur adsorbed by the sorbent was decreasing in the same way as removal efficiency with increase in sorbent working time. The trend is apparently determined by saturation of material which is occurring concurrently with sorbent working time, therefore, decreasing the adsorption process. When saturation point is reached, both RE and mass of H<sub>2</sub>S adsorbed are zero showing that initial and final concentrations are equal.

Carbon-based sorbents have several mechanisms through which H<sub>2</sub>S could be adsorbed. Activated carbon produced with KOH activation is motivated by the pore structure, chiefly with micropores rather than surface chemistry (Mochizuki, Kubota, Matsuda & Camacho, 2016). That means H<sub>2</sub>S adsorption is based on pore structure favouring physisorption, which occurs between H<sub>2</sub>S molecule and carbon surface. Activation results in widened spaces between carbon atomic layers, thus increasing the total pore volume influencing physisorption. However, the sweet potato leaves AC contains iron which can also contribute to adsorption as shown in Eq. (4).



From the measurement of H<sub>2</sub>S concentrations after the filter, breakthrough time and saturation time was determined; the BT values and other results are compared for sweet potato leaves non-activated and activated carbon in Table 6. The AC sorbent material produced is composed of both micropores and mesopores as shown in Table 6. 1.0 g of both samples with activation ratio KOH: C 1:1 was used to calculate SC and RE whereby, AC has better results than C. The results are since AC is more porous which influence high surface area leading to high RE and SC.

The regenerated ability of the sweet potato leaves AC was evaluated. After saturation was reached spent AC with T<sub>c</sub> 800 °C and activation ratio 1:1 KOH: C was regenerated through a thermal process under the flow of nitrogen gas and being studied to check its performance in comparison with the fresh prepared AC800 with KOH: C 1:1. The regenerated sample has been found to have lower SC of about 0.9 g S/100 g compared to the freshly prepared sample, which is 1.9 g S/100 g. Sorbent working time for fresh sample is longer than that of the regenerated sample as shown in Fig. 9, the BTs for fresh and regenerated samples are 170 and 80 min. respectively. The results indicate that the regenerated sample is getting saturated faster as compared to the freshly prepared sample, that could be caused by the fact that regeneration was not complete thus the sorption capacity of the sorbent prepared is reduced.

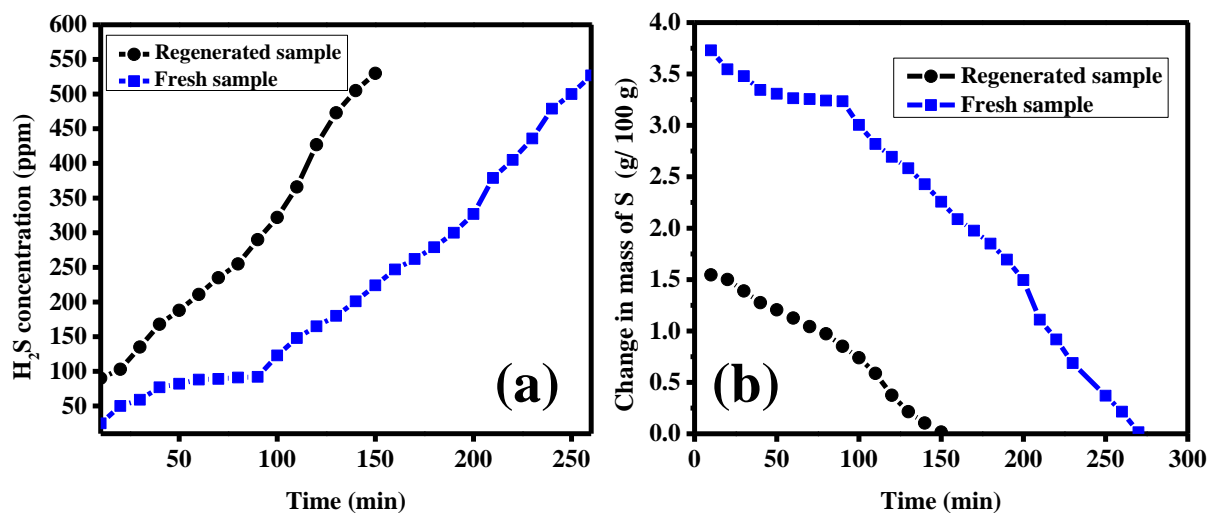

**Figure 9: Comparison between the fresh sample and regenerated sample: (a) H<sub>2</sub>S concentration after sorption by regenerated sample; (b) Change in mass of sulfur during sorbent working time. Test conditions: T<sub>c</sub> = 800 °C, FR = 0.02 m<sup>3</sup>/h, KOH: C 1:1, m = 1.0 g, C<sub>i</sub> = 535 ppm**

Properties of the sweet potato leaves AC are compared to other adsorbent materials which were also used to remove H<sub>2</sub>S from biogas, as shown in Table 7. One can see that sweet potato leaves AC has reasonable SC, although it is less than that of zeolite and coconut shell AC. However, zeolite is rock material; thus, its mining enhances land degradation, and it is not abundantly locally available. In addition to that coconut shell is not abundantly locally available.

**Table 7: Comparison of the sweet potato leaves AC with other material**

Adsorbent	RE (%)	SC (g S/100 g sorbent)	References
Volcanic ash	96	1.0	Kandola <i>et al.</i> (2018)
Water hyacinth AC	93	-	Makauki <i>et al.</i> (2017)
Coconut shell AC	-	2.03	Choo <i>et al.</i> (2013)
Zeolite	-	13.3 - 25.2	Sigot <i>et al.</i> (2016)
Maize cob waste AC	-	1.6	Surra <i>et al.</i> (2019)
Laterite	92	-	Thanakunpaisit, Jantarachat and Onthong (2017)
Sweet potato leaves AC	95	1.9	This study

## CHAPTER FIVE

### CONCLUSION AND RECOMMENDATIONS

#### 5.1 Conclusion

In this study, carbonized and activated samples prepared from sweet potato leaves were studied as sorbents for the H<sub>2</sub>S removal from biogas. The results showed that activated sample had higher removal efficiency than carbonized samples whereby the removal efficiency increased with increase in carbonization temperature. Then the activated carbon with the highest carbonization temperature was tested for different parameters including activation ratio, flow rate and mass of sorbent.

- (i) According to results the sample carbonized at 800 °C with activation ratio 1:1 KOH: C showed highest removal efficiency of about 95% and sorption capacity of approximately 1.9 g S/ 100 g sweet potato leaves AC.
- (ii) Structural properties were studied using BET analysis, and the results showed that activated carbon had higher surface area and pore volume as compared to the carbonized sample.
- (iii) The elemental analysis, which was performed by XRF showed the presence of Fe<sub>2</sub>O<sub>3</sub>, which was significant for the adsorption process.
- (iv) The SEM micrographs indicated that there were rough surfaces with pores contained on the surface of fresh AC which were then filled after the adsorption process.
- (v) The regeneration study, which was performed involving a single cycle, has revealed that the AC can be reused after regeneration instead of disposing it.
- (vi) Therefore, novel adsorbent, sweet potato leaves derived activated carbon is a feasible option for hydrogen sulfide removal from biogas.



## 5.2 Recommendations

Though the objectives of this study were fulfilled, the author would like to give the following recommendations to improve further researches:

- (i) Sorbent performance could be improved by raising the activation ratio, KOH: C; the samples with the activation ratio above 1:1 KOH: C should be studied.
- (ii) The material should be modified to ease the flow of biogas through the sample in a bed reactor.
- (iii) The adsorption test should be performed under well-controlled conditions; all facilities required during the adsorption test, including the biogas plant prototype must be available in the laboratory.
- (iv) Further regeneration cycles should be carried out to study the adsorption efficiency of regenerated AC.

## REFERENCES

- Allmarah, K. A., Lafta, T. M., Jabr, A. K., & Mohammad, A. N. (2017). Desulfurization for Biogas Generated by Lab Anaerobic Digestion unit. *Journal of Agriculture and Veterinary Science*, 10(8), 66-73. doi: 10.9790/2380-1008036673.
- Amagloh, F., Atuna, R., McBride, R., Carey, E., & Christides, T. (2017). Nutrient and total polyphenol contents of dark green leafy vegetables, and estimation of their iron bioaccessibility using the in vitro digestion/Caco-2 cell model. *Foods*, 6(7), 54. doi: 10.3390/foods6070054.
- Baena, M. F., Rodríguez, G. M., Vega, F., Vilches, L. F., & Navarrete, B. J. (2019). recent advances in biogas purifying technologies. *International Journal of Green Energy*, 16(5), 401-412. doi: 10.1080/15435075.2019.1572610.
- Belmabkhout, Y., Dewireld, G., & Sayari, A. (2009). Amine-bearing mesoporous silica for CO<sub>2</sub> and H<sub>2</sub>S removal from natural gas and biogas. *Langmuir*, 25(23), 13275-13278. doi: 10.1021/la903238y.
- Choo, H. S., Lau, L. C., Mohamed, A. R., & Lee, K. (2013). Hydrogen sulfide adsorption by alkaline impregnated coconut shell activated carbon. *Journal of Engineering Science and Technology*, 8(6), 741-753. Retrieved from [http://jestec.taylors.edu.my/Vol%208%](http://jestec.taylors.edu.my/Vol%208%20).
- Chung, Y. C., Ho, K. L., & Tseng, C. (2007). Two-stage biofilter for effective NH<sub>3</sub> removal from waste gases containing high concentrations of H<sub>2</sub>S. *Journal of the Air & Waste Management Association*, 57(3), 337-347. doi: 10.1080/10473289.2007.10465332.
- Daud, W. M., Ali, W. S., & Sulaiman, M. (2000). The effects of carbonization temperature on pore development in palm-shell-based activated carbon. *Carbon*, 38(14), 1925-1932. doi: 10.1016/S0008-6223(00)00028-2.
- Florin, N. H., & Harris, A. T. (2008). Enhanced hydrogen production from biomass with in situ carbon dioxide capture using calcium oxide sorbents. *Chemical Engineering Science*, 63(2), 287-316. doi: 10.1016/j.ces.2007.09.011.

- Gabriel, D., & Deshusses, M. A. (2003). Retrofitting existing chemical scrubbers to biotrickling filters for H<sub>2</sub>S emission control. *Proceedings of the National Academy of Sciences*, 100(11), 6308-6312. doi: 10.1073/pnas.0731894100.
- Garces, H. F., Espinal, A. E., & Suib, S. L. (2012). Tunable shape microwave synthesis of zinc oxide nanospheres and their desulfurization performance compared with nanorods and platelet-like morphologies for the removal of hydrogen sulfide. *The Journal of Physical Chemistry*, 116(15), 8465-8474. doi: 10.1021/jp210755t.
- Gebreegziabher, T. B., Wang, S., & Nam, H. (2019). Adsorption of H<sub>2</sub>S, NH<sub>3</sub> and TMA from Indoor Air Using Porous Corncob Activated Carbon: Isotherm and Kinetics Study. *Journal of Environmental Chemical Engineering*, 7(4), 103234. doi: 10.1016/j.jece.2019.103234.
- Hayashi, J. I., Kazehaya, A., Muroyama, K., & Watkinson, A. P. (2000). Preparation of activated carbon from lignin by chemical activation. *Carbon*, 38(13), 1873-1878. doi: 10.1016/S0008-6223(00)00027-0.
- Huang, L. C., & Ko, T. (2015). Feasibility application of Cu contaminated soil on the removal of H<sub>2</sub>S from hot coal gas. *Materials Transactions*, 56(3), 445-449. doi: 10.2320/materials.M2014393.
- Huang, Y., Li, S., Chen, J., Zhang, X., & Chen, Y. (2014). Adsorption of Pb (II) on mesoporous activated carbons fabricated from water hyacinth using H<sub>3</sub>PO<sub>4</sub> activation: Adsorption capacity, kinetic and isotherm studies. *Applied Surface Science*, 293, 160-168. doi: 10.1016/j.apsusc.2013.12.123.
- Ishida, H., Suzuno, H., Sugiyama, N., Innami, S., Tadokoro, T., & Maekawa, A. (2000). Nutritive evaluation on chemical components of leaves, stalks and stems of sweet potatoes (*Ipomoea batatas* poir). *Food Chemistry*, 68(3), 359-367. doi: 10.1016/S0308-8146(99)00206-X.
- Kandola, I., Pogrebnoi, A., & Pogrebnyaya, T. (2018). Oldoinyo Lengai Volcanic Ash for Removal of Hydrogen Sulfide and Ammonia from Biogas. *Journal of Materials Science and Chemical Engineering*, 6(04), 78-93. doi: 10.4236/msce.2018.64010

- Kaneko, K., Ishii, C., & Ruike, M. (1992). Origin of superhigh surface area and microcrystalline graphitic structures of activated carbons. *Carbon*, 30(7), 1075-1088. doi: 10.1016/0008-6223(92)90139-N.
- Kanjanarong, J., Giri, B. S., Jaisi, D. P., Oliveira, F. R., Boonsawang, P., Chaiprapat, S., ... Khanal, S. K. (2017). Removal of hydrogen sulfide generated during anaerobic treatment of sulfate-laden wastewater using biochar: evaluation of efficiency and mechanisms. *Bioresource Technology*, 234, 115-121. doi: 10.1016/j.biotech.2017.03.009.
- Karuga, J., Jande, Y. A., Kim, H. T., & King'ondy, C. (2016). Fish swim bladder-derived porous carbon for defluoridation at potable water pH. *Chemistry & Materials Science*, 6(04), 500-514. doi: 10.4236/aces.2016.64044.
- Lien, C. C., Lin, J. L., & Ting, C. (2014). Water scrubbing for removal of hydrogen sulfide (H<sub>2</sub>S) in biogas from hog farms. *Journal of Agricultural Chemistry and Environment*, 3(2), 1-6. doi: 10.4236/jacen.2014.32B001.
- Ma, H. T., Ly, H. C., Pham, N. B., Nguyen, D. C., Vo, K. D., & Tuan, P. (2017). Effect of the carbonization and activation process on the adsorption capacity of rice husk activated carbon. *Vietnam Journal of Science and Technology*, 55(4), 494-502. doi: 10.15625/2525-2518/55/4/9124.
- Maia, D. S., Niklevicz, R. R., Arioli, R., Frare, L. M., Arroyo, P. A., Gimenes, M. L., & Pereira, N. C. (2017). Removal of H<sub>2</sub>S and CO<sub>2</sub> from biogas in bench scale and the pilot scale using a regenerable Fe-EDTA solution. *Renewable Energy*, 109, 188-194. doi: 10.1016/j.renene.2017.03.023.
- Makauki, E., King'ondy, C. K., & Kibona, T. E. (2017). Hydrogen sulfide and ammonia removal from biogas using water hyacinth-derived carbon nanomaterials. *African Journal of Environmental Science and Technology*, 11(7), 375-383. doi: 10.5897/AJEST2016.2246.
- Mitomo, A., Sato, T., Kobayashi, N., Hatano, S., Itaya, Y., & Mori, S. (2003). Adsorption removal of hydrogen sulfide by activated coke produced from wood pellet in the recycle

- system of biomass. *Journal of Chemical Engineering of Japan*, 36(9), 1050-1056. doi: 10.1252/jcej.36.1050.
- Mochizuki, T., Kubota, M., Matsuda, H., & Camacho, L. E. (2016). Adsorption behaviors of ammonia and hydrogen sulfide on activated carbon prepared from petroleum coke by KOH chemical activation. *Fuel Processing Technology*, 144, 164-169. doi: 10.1016/j.fuproc.2015.12.012.
- Niesner, J., Jecha, D., & Stehlík, P. (2013). Biogas upgrading technologies: state of the art review in the European region. *Chemical Engineering Transactions*, 35, 517-522. doi: 10.3303/CET1335086.
- Peiffer, S., & Gade, W. (2007). Reactivity of ferric oxides toward H<sub>2</sub>S at low pH. *Environmental Science and Technology*, 41(9), 3159-3164. doi: 10.1021/es062228d.
- Pokorna, L., Bartacek, J., Vejmelkova, D., Alvarez, A. A., Slukova, P., Prochazka, J., Volcke, E. I., & Jenicek, P. (2017). The use of a silicone based biomembrane for microaerobic H<sub>2</sub>S removal from biogas. *Separation and Purification Technology*. 189, 145-152. doi: 10.1016/j.seppur.2017.07.077.
- Ramírez, S. D., Zarate, P. B., Guerrero, B. C., & Garcia, E. (2009). H<sub>2</sub>S and volatile fatty acids elimination by biofiltration: Clean-up process for biogas potential use. *Journal of Hazardous Materials*, 163(3), 1272-1281. doi: 10.1016/j.jhazmat.2008.07.129.
- Ros, A., Lillo, M., Fuente, E., Montes, M., Martín, M., & Linares, A. (2006). High surface area materials prepared from sewage sludge-based precursors. *Chemosphere*, 65(1), 132-140. doi: 10.1016/j.chemosphere.2006.02.017.
- Saygılı, H., & Güzel, F. (2016). High surface area mesoporous activated carbon from tomato processing solid waste by zinc chloride activation: process optimization, characterization and dyes adsorption. *Journal of Cleaner Production*, 113, 995-1004. doi: 10.1016/j.jclepro.2015.12.055.
- Sigot, L., Ducom, G., & Germain, P. (2016). Adsorption of hydrogen sulfide (H<sub>2</sub>S) on zeolite (Z): Retention mechanism. *Chemical Engineering Journal*, 287, 47-53. doi: 10.1016/j.cej.2015.11.010.

- Sudaryanto, Y., Hartono, S., Irawaty, W., Hindarso, H., & Ismadji, S. (2006). High surface area activated carbon prepared from cassava peel by chemical activation. *Bioresource Technology*, 97(5), 734-739. doi: 10.1016/j.biortech.2005.04.029.
- Sun, H., Mu, T., Xi, L., Zhang, M., & Chen, J. (2014). Sweet potato (*Ipomoea batatas* L.) leaves as nutritional and functional foods. *Food Chemistry*, 156, 380-389. doi: 10.1016/j.food chem.2014.01.079.
- Surra, E., Nogueira, M. C., Bernardo, M., Lapa, N., Esteves, I., & Fonseca, I. (2019). New adsorbents from maize cob wastes and anaerobic digestate for H<sub>2</sub>S removal from biogas. *Waste Management*, 94, 136-145. doi: 10.1016/j.wasman.2019.05.048.
- Tan, I., Ahmad, A., & Hameed, B. (2008). Preparation of activated carbon from coconut husk: Optimization study on removal of 2, 4, 6-trichlorophenol using response surface methodology. *Journal of Hazardous Materials*, 153(2), 709-717. doi: 10.1016/j.jhaz mat.2007.09.014.
- Teng, H., Yeh, T., & Hsu, L. (1998). Preparation of activated carbon from bituminous coal with phosphoric acid activation. *Carbon*, 36(9), 1387-1395. doi: 10.1016/S0008-6223(98) 00127-4.
- Thanakunpaisit, N., Jantarachai, N., & Onthong, U. (2017). Removal of hydrogen sulfide from biogas using laterite materials as an adsorbent. *Energy Procedia*, 138, 1134-1139. doi: 10.1016/j.egypro.2017.10.215.
- Üner, O., & Bayrak, Y. (2018). The effect of carbonization temperature, carbonization time and impregnation ratio on the properties of activated carbon produced from arundo donax. *Microporous and Mesoporous Materials*, 268, 225-234. doi: 10.1016/j.micromeso. 2018.04.037.
- Van, O., Lucka, K., Köhne, H., Schade, T., & Andersson, J. (2008). Selective removal of sulphur in liquid fuels for fuel cell applications. *Fuel Processing Technology*, 87(14), 2988-2996. doi: 10.1016/j.fuel.2008.03.020.

- Wei, X., Li, Y., & Gao, S. (2016). Biomass derived interconnected carbon nanoring electrochemical capacitors with high performance in both strongly acidic and alkaline electrolytes. *Journal of Material Chemistry*, 5(1), 181-188. doi: 10.1039/C6TA07826E.
- Xu, G., Yang, X., & Spinosa, L. (2015). Development of sludge-based adsorbents: preparation, characterization, utilization and its feasibility assessment. *Journal of Environmental Management*, 151, 221-232. doi: 10.1016/j.jenvman.2014.08.001.
- Żarczyński, A., Rosiak, K., Anielak, P., & Wolf, W. (2014). Practical methods of cleaning biogas from hydrogen sulphide. Part 1: Application of solid sorbents. *Acta Innovations*, 12, 24-34. Retrieved from <https://www.ceeol.com/search/article-detail?id613707>.